



Montage-handleiding elektrokabelset voor
trekhaak met 12-N contactdoos
vlg. DIN/ISO norm 1724

Fitting instructions electric wiringkit
towbar with 12-N socket up to
DIN/ISO norm 1724

Einbauanleitung Elektrosatz
Anhängervorrichtung mit 12-N Steckdose
lt. DIN/ISO Norm 1724

Instructions de montage du faisceau
électrique pour crochet d'attelage
conforme à la norme DIN/ISO 1724
prise 12-N

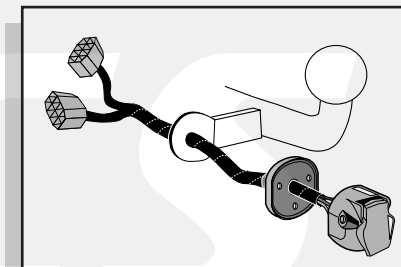

MAZDA 626 Sedan/Hatchback/Station 1997-

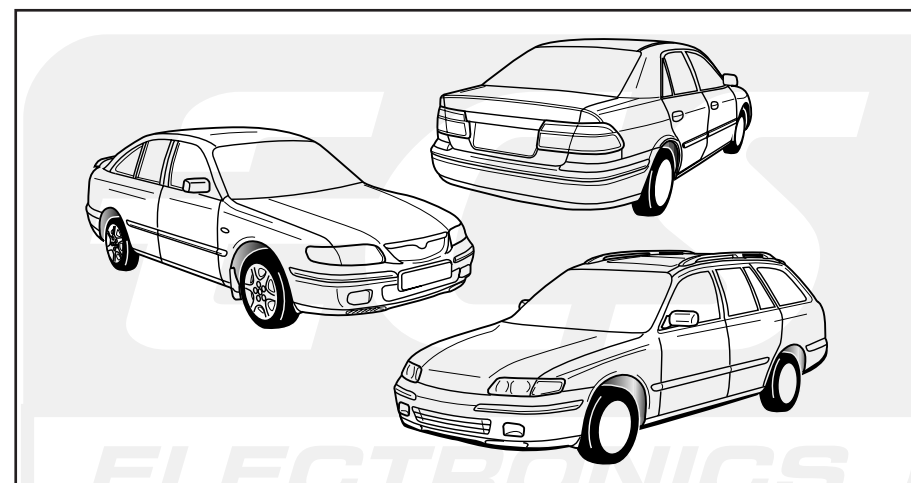

Bestel Nr.: MAZ-049-B

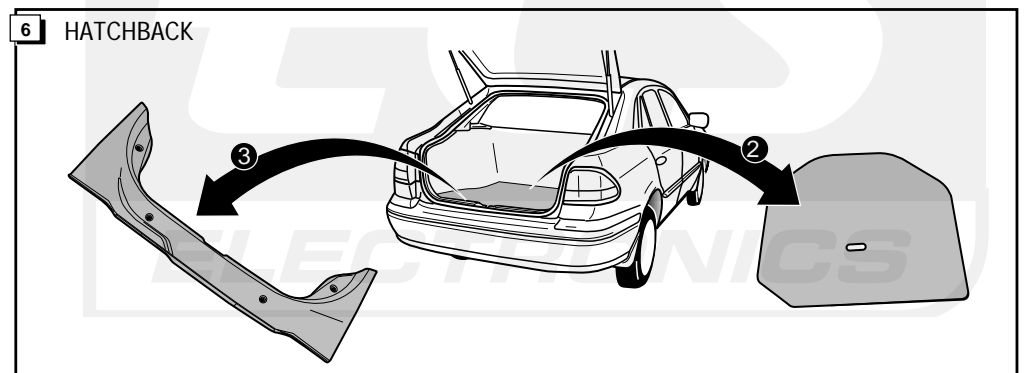
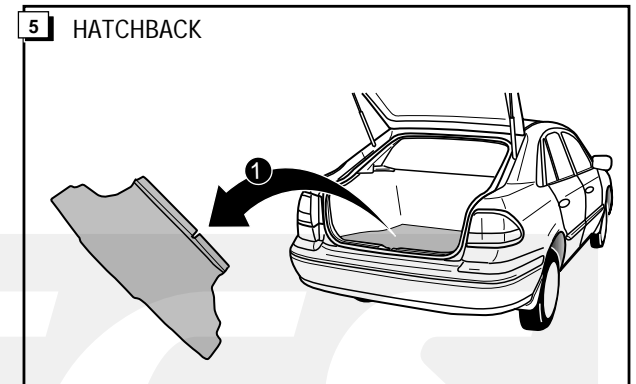
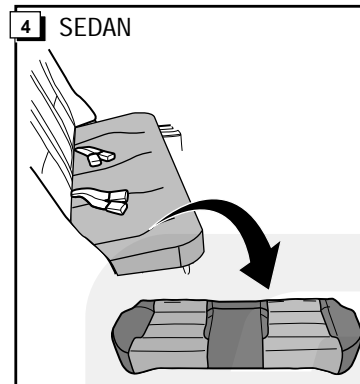
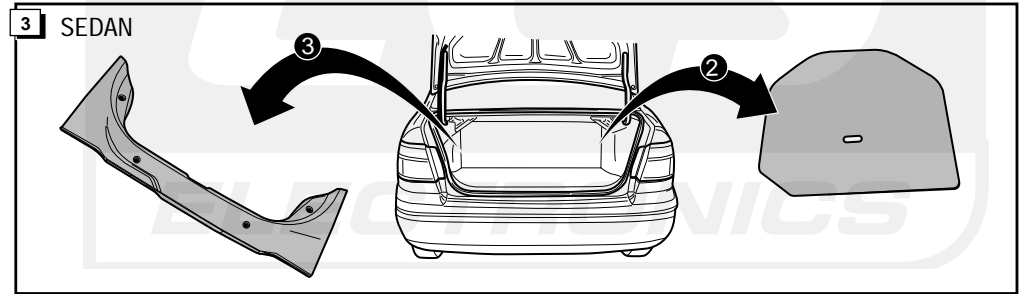
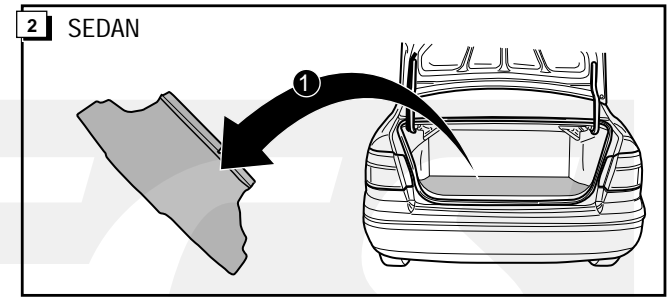
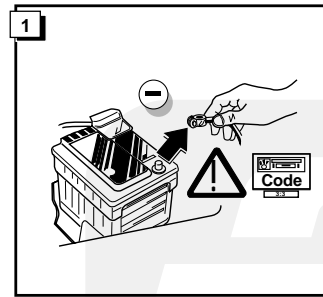

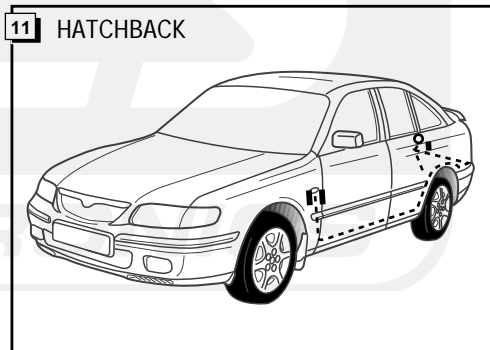
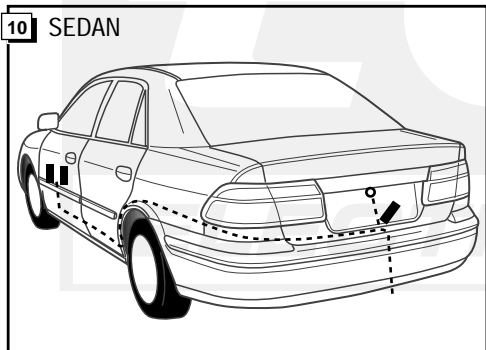
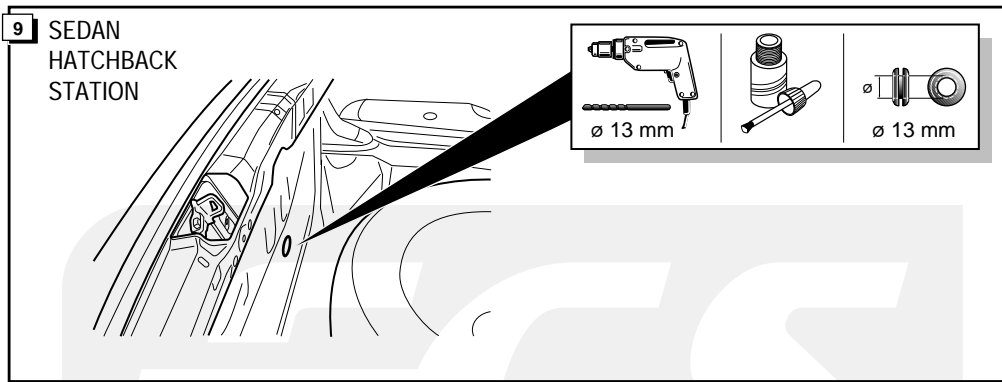
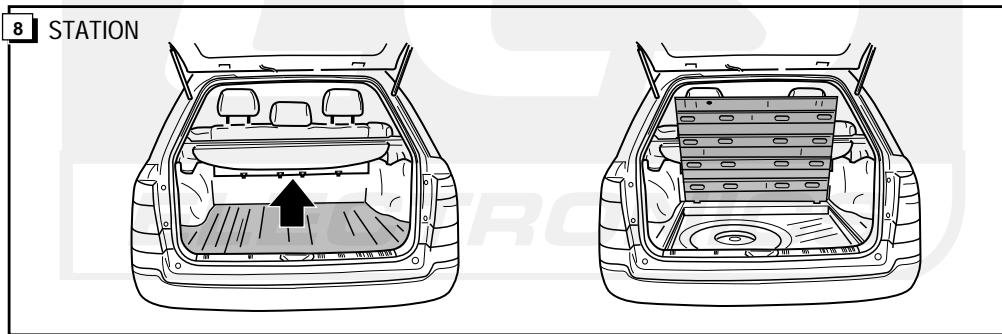
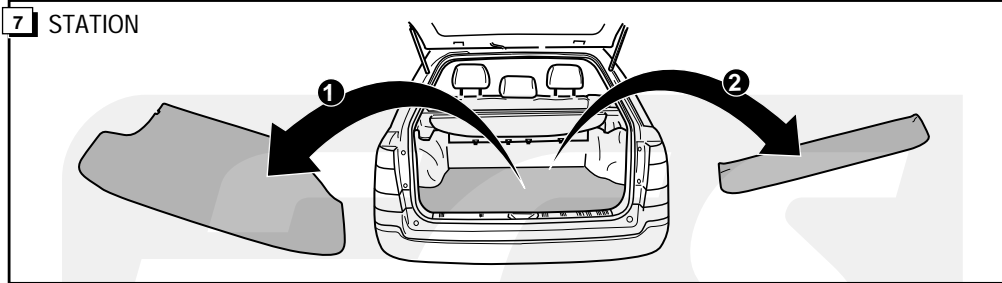

21 STATION

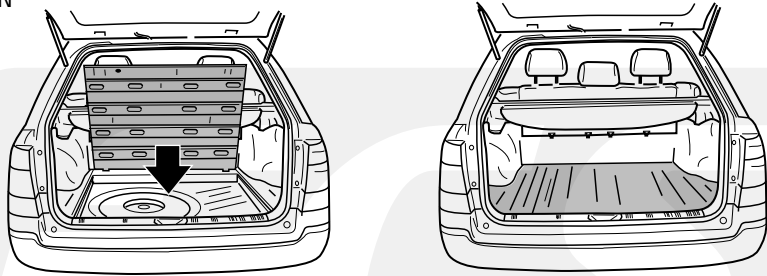

12 STATION

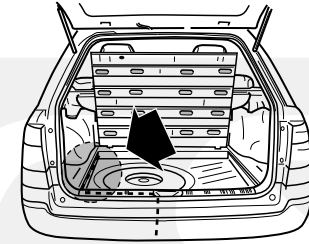
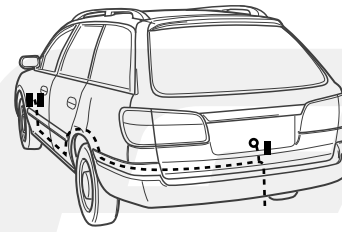

22 STATION

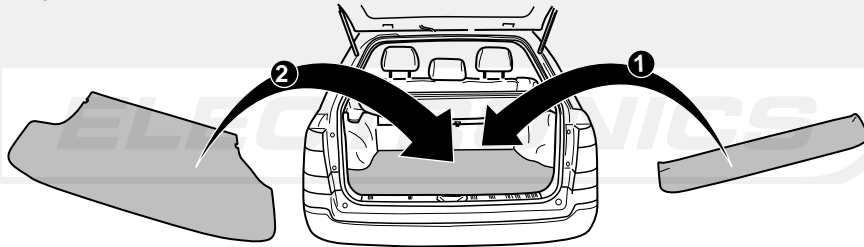

23

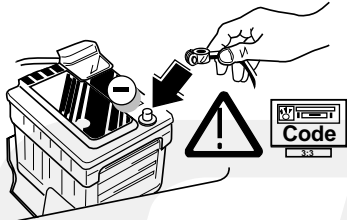

24

! **CONTROLEER FUNCTIES !**
! **CHECK FUNCTIONS !**
! **FUNKTIONEN KONTROLIEREN !**
! **CONTRÔLER LES FONCTIONS !**

13

	NL	GB	D	F
1=L	GEEL	YELLOW	GELB	JAUNE
2=54-G	BLAUW	BLUE	BLAU	BLEU
3=31	WIT	WHITE	WEIß	BLANC
4=R	GROEN	GREEN	GRÜN	VERT
5=58-R	ZWART	BLACK	SCHWARZ	NOIR
6=54	ROOD	RED	ROT	ROUGE
7=58-L	ZWART	BLACK	SCHWARZ	NOIR
8=58-B	GRIJS	GREY	GRAU	GRIS

BLACK JUMPER WIRE

14 SEDAN
 HATCHBACK
 STATION

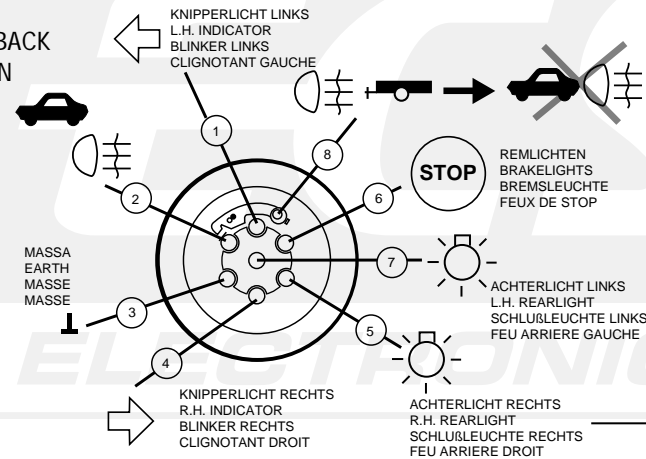

BLACK JUMPER WIRE

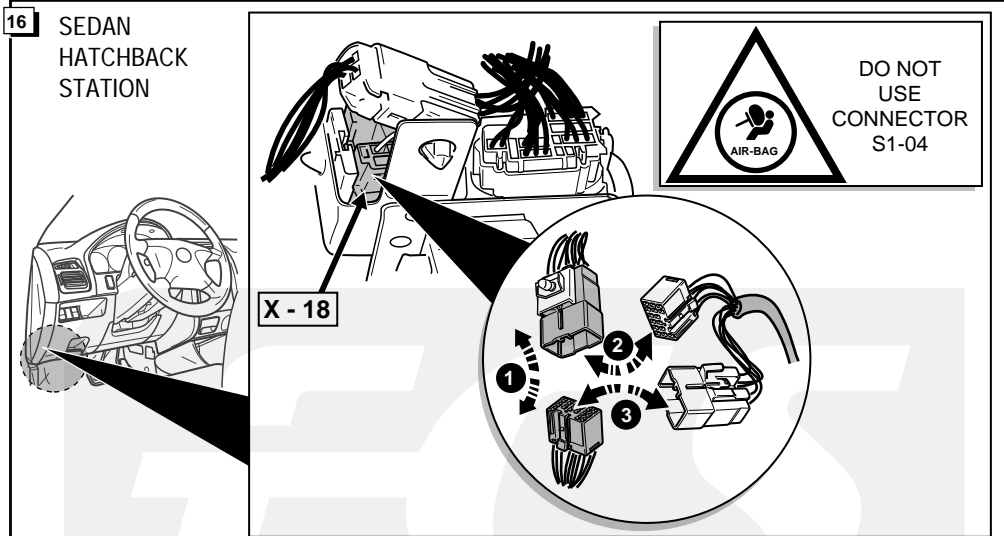
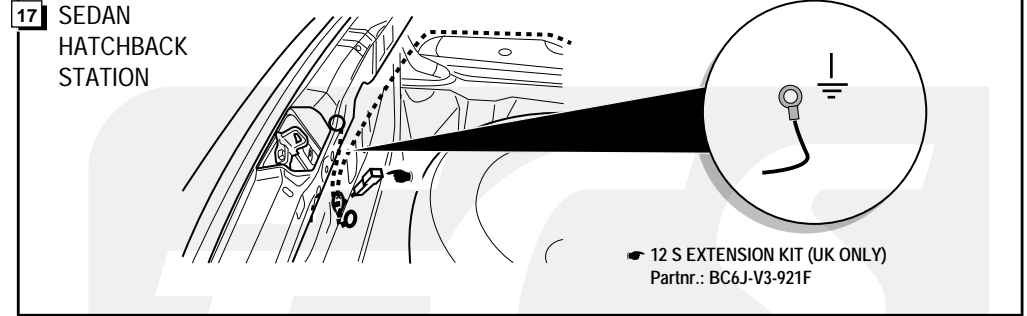
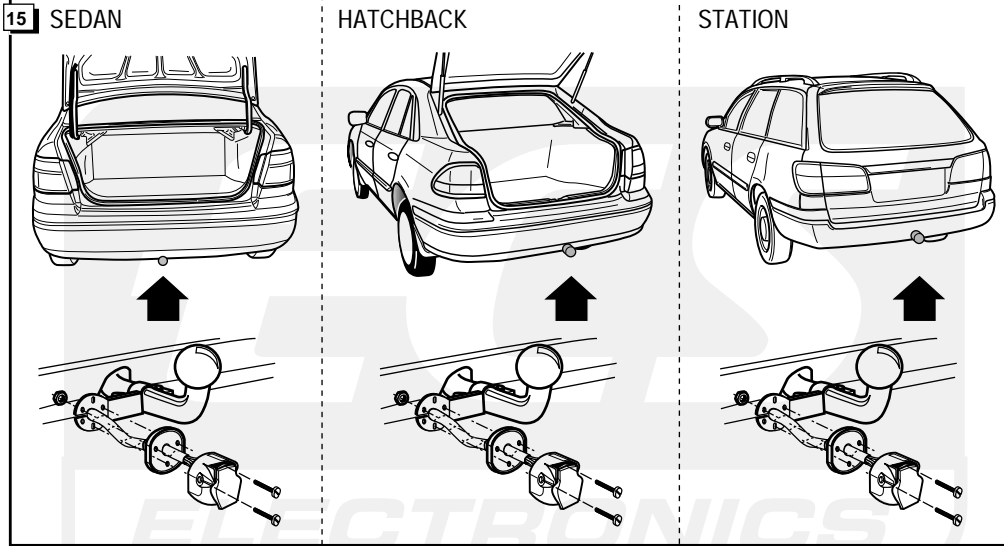

X-18 FRONT(F) - INTERIOR (IN)

(F)					(IN)				
*	*			R	*			<L/W>	(R/G)
(R/G)	<L/W>				*			<R/L>	P
(P)	<R/L>	LY	G/W	Y/R	R/B	*	Y/R	G/W	LY
*	LG/B	G/Y	G/B	GY/B	Y/G	*	*	G/B	G/Y
	[LG/R]					*		LG/B	*

[] WITH RUNNING LIGHT SYSTEM, <> 5HB, () WITH THEFT-DETERRENT SYSTEM

