



VCA Headquarters

1 The Eastgate Office Centre
Eastgate Road
Bristol, BS5 6XX
United Kingdom

Switchboard: +44 (0) 117 951 5151
Direct line: +44 (0) 117 952 4171
Main Fax: +44 (0) 117 952 4103
Email: enquiries@vca.gov.uk
Web: www.vca.gov.uk

THE UNITED KINGDOM VEHICLE APPROVAL AUTHORITY

Rev 1/03



COMMUNICATION CONCERNING THE APPROVAL GRANTED OF
A REPLACEMENT BRAKE LINING ASSEMBLY OR REPLACEMENT
DRUM LINING PURSUANT TO ECE REGULATION NO: 90.01

Approval No: 90R-01200/ 3642.

1. Applicant's name and address:

Juratek Ltd. Unit 16, Carcroft Enterprise Park, Station Road, Doncaster DN6 8DD

2. Manufacturer's name and address:

3. Make and type of brake lining assembly: DP11390.

4. Make and type of brake lining: LE M09A FF

5. Vehicles/axles/brakes for which the brake lining assembly/drum brake lining type qualifies as original brake lining assembly: Not applicable

6. Vehicles for which the brake lining assembly qualifies as replacement brake lining assembly:

An executive agency of the Department for Transport



7. Submitted for approval on: 4 May 2007
8. Technical Service responsible for approval tests: Vehicle Certification Agency
- 8.1 Date of test report: 3/11/06, 15/11/06, 24/05/06, 17/04/07, 17/04/07.
- 8.2 Number of test reports : VSG078115, VSG173037, VSF066709, VSG177009,
VSG177010.
9. Approval GRANTED
10. Place: BRISTOL
11. Date: 30 MAY 2007
12. Signature:  A. W. STENNING
Head of Product Certification
13. Annexed to this communication is a list of documents in the approval file deposited at the administrative services having delivered the approval and which can be obtained upon request.

VSG177016



04/05/07	VCA Job No	VSG177016
----------	-------------------	-----------

Dear Claire,

Please find enclosed the necessary documentation for you to submit applications for approval for various brake lining assemblies DP11390 in LE M09A FF material pursuant to ECE Regulation No. 90/1. This application is on behalf of Juratek Ltd and cross-references to our DP LE M09A FF application details. We would like the application made to the VCA; I have addressed the formal letter of application accordingly.

The documents contained are: -

1. Formal letter of application
2. Manufacturers declarations
3. Lab test results :-
 - Friction test results
 - Shear test results
 - Compressibility test results
4. Vehicle fitment details
5. Disc pad assembly drawings
6. General disc pad marking drawing

Please note: Allocated with E11 90R-01200/3642

This approval is based on VSG078115, VSG173037 and VSF066709 plus additional OE Materials testing on VSG177009 and VSG177010.

Yours sincerely,



Susan Owens
Q.B.T.



04/05/07	VCA Job No	VSG177016
----------	-------------------	-----------

Vehicle Certification Agency
 1 Eastgate Office Centre
 Eastgate Road
 Bristol
 BS5 6XX

Letter of application for an approval pursuant to ECE Regulation No. 90/1

Dear Sirs,

Herewith we apply for an approval for our brake lining assembly pursuant to ECE Regulation No. 90/1.

Applicants name and address:

Juratek Ltd. Unit 16, Carcroft Enterprise Park, Station Road, Doncaster DN6 8DD

Manufacturers name and address:

Make and type of brake lining	LE M09A FF
Make and type of brake lining assembly	as listed below

Assembly Number	Assembly Contains...(see enclosed drawings)	Material Code
DP11390	4 identical pads	LE M09A FF



04/05/07	VCA Job No	VSG177016
----------	-------------------	-----------

For vehicles / axles / brakes for which the lining assembly qualifies as replacement brake lining assembly, see following application list.

Assembly Number	Equivalent to	Also supplied as Assembly Number
DP11390 LE M09A FF	Equivalent to	
	Equivalent to	

Yours faithfully



Susan Owens
Q.B.T.



04/05/07	VCA Job No	VSG177016
----------	------------	-----------

Manufacturer's Declaration

for granting of Approval for replacement brake lining according to ECE Regulation No. 90/1.

We, the company

declare herewith that

Replacement pad assemblies DP11390 LE M09A FF

are produced in our factory

We certify that no application has been made regarding this permission/approval by us or by companies appointed by us in countries which as contract parties would also be entitled to grant permission/approval.

We are aware of the following: -

A type marking of vehicles/vehicle components of the above mentioned type with the officially assigned approval mark can only be granted if the products have been manufactured in the above mentioned factory or at one of our listed and approved manufacturing sites, and if they comply with the official approval documents.

Companies manufacturing products for our company or under license may not use the officially assigned approval mark for vehicles/vehicle components produced at their factories unless they are listed as an approved manufacturing site, and fully comply with our quality procedures.

A marking of vehicles/vehicle components of the above mentioned type with different factory or trade marks but the same approval mark is only permissible if written consent has been obtained from the Vehicle Certification Agency.



Susan Owens
Q.B.T.



04/05/07	VCA Job No	VSG177016
----------	------------	-----------

Friction test results

Conducted in accordance with Annex 8, of ECE Regulation No. 90 Rev1 including supplement 2 to the 01 series of amendments. (TRANS/SC1/WP29/GRRF/R90 Rev 1).

Type of assembly: Part Number DP1143 in material LE M09A FF
(Previously agreed single test reference)

Type of test:	Constant torque (para. 2.2.2.2)
$\mu_{op: 1}$	0.37
$\mu_{op: 2}$	0.39
μ_{min} :	0.29
μ_{max} :	0.41

Test dates: 11/02/2007



Susan Owens
Q.B.T.



04/05/07	VCA Job No	VSG177016
----------	------------	-----------

Bench tests

Manufacturer:			
Type of brake lining assy:	DP1143 LE M09A FF	Page	1/2

1. Shear strength test¹
(5.3.2.1 of ECE Regulation No. 90 Rev 1)

- Sample

Type of assembly: DP1143 LE M09A FF
Shear area [cm²]: 46.24

- Shear strength measured

Mean value [N/cm²]: 564.4
Required [N/cm²]: 250

Test date: 10/02/2007

1) Test procedure according to ISO Standard 6312 (2001)



Susan Owens
Q.B.T.



04/05/07	VCA Job No	VSG177016
----------	------------	-----------

Manufacturer:			
Type of brake lining assy:	LE M09A FF	Page	2/2

2. Compressibility test²
(5.3.2.2 of ECE Regulation No. 90 Rev 1)

- Sample

Type: III
 Type of assembly: LE M09A FF
 Thickness, d_0 (nominal value) [mm]: 15.0
 Pad area [cm²]: 46.24
 Ram dia (corresponding to caliper piston dia) [mm]: 60

- Compressibility at specific surface pressure of 8000 kPa

Measured at ambient temperature

Mean value: $\frac{d_4 - d'_3}{d_0} = 0.45 \%$

Required: $\leq 2\%$

Measured at 400°C

Mean value: $\frac{d_4 - d'_3}{d_0} = 1.49\%$

Required: $\leq 5\%$

Test dates: 10/02/2007

2) Test procedure according to ISO Standard 6310 (2001)



Susan Owens
Q.B.T.



MAKE	MODEL 1	MODEL 2	MODEL 3	MODEL 4	MODEL 5	F/R	D	A	T	E	OE Caliper Manufacturer	S/V Dr	Disc / Dia	Disc / Shoe Width	Max Th
DP11390	IVECO (Includes Iveco Fiat, Iveco Ford, M) Daily 99-->	60 C13				F	07	99			Brembo	S	290	22	
DP11390	IVECO (Includes Iveco Fiat, Iveco Ford, M) Daily 99-->	60 C13					R	07	99		Brembo	S	289	22	
DP11390	IVECO (Includes Iveco Fiat, Iveco Ford, M) Daily 99-->	65 C13				F	07	99			Brembo	S	290	22	
DP11390	IVECO (Includes Iveco Fiat, Iveco Ford, M) Daily 99-->	65 C13					R	07	99		Brembo	S	289	22	
DP11390	IVECO (Includes Iveco Fiat, Iveco Ford, M) PSV's Daily 99-->	60 C13				F	07	99			Brembo	S	290	22	
DP11390	IVECO (Includes Iveco Fiat, Iveco Ford, M) PSV's Daily 99-->	60 C13					R	07	99		Brembo	S	289	22	
DP11390	IVECO (Includes Iveco Fiat, Iveco Ford, M) PSV's Daily 99-->	65 C13				F	07	99			Brembo	S	290	22	
DP11390	IVECO (Includes Iveco Fiat, Iveco Ford, M) PSV's Daily 99-->	65 C13					R	07	99		Brembo	S	289	22	
DP11390	RENAULT	Mascot	110, 130, 150			F	10	00			Brembo	V	290.0	22	
DP11390	RENAULT	Mascot	110, 130, 150			F	10	00			Brembo	V	290	26	



CALIPER ACTUATION	BRAKING SPLIT F/R, DIAG or H / I	CALIPER PAD		HERST NUMBER	TYP / SCHL NUMBER	MAX SPEED Km/h	80% V MAX Km/h	VEHICLE / AXLE WEIGHT		ENERGY FACTOR .5 MV 2	MAXIMUM ROLLING RADIUS	INERTIA UNLADEN	VEHICLE INERTIA	
		PISTON DIA	FRICTION AREA mm^2					UN-LADEN	LADEN				LADEN	AXLE INERTIA LADEN
Hyd		2x 52				150	120	6000	43200000	0.33	0	251.559	0	
Hyd		2x 46				150	120	6000	43200000	0.33	0	104.544	0	
Hyd		2x 52				150	120	6500	46800000	0.33	0	272.52225	0	
Hyd		2x 46				150	120	6500	46800000	0.33	0	113.256	0	
Hyd		2x 52				150	120	6000	43200000	0.33	0	251.559	0	
Hyd		2x 46				150	120	6000	43200000	0.33	0	104.544	0	
Hyd		2x 52				150	120	6500	46800000	0.33	0	272.52225	0	
Hyd		2x 46				150	120	6500	46800000	0.33	0	113.256	0	
Hyd		2x 52		3004		150	120	6500	46800000	0.33	0	272.52225	0	
Hyd		2x 52		3004		150	120	6500	46800000	0.33	0	272.52225	0	



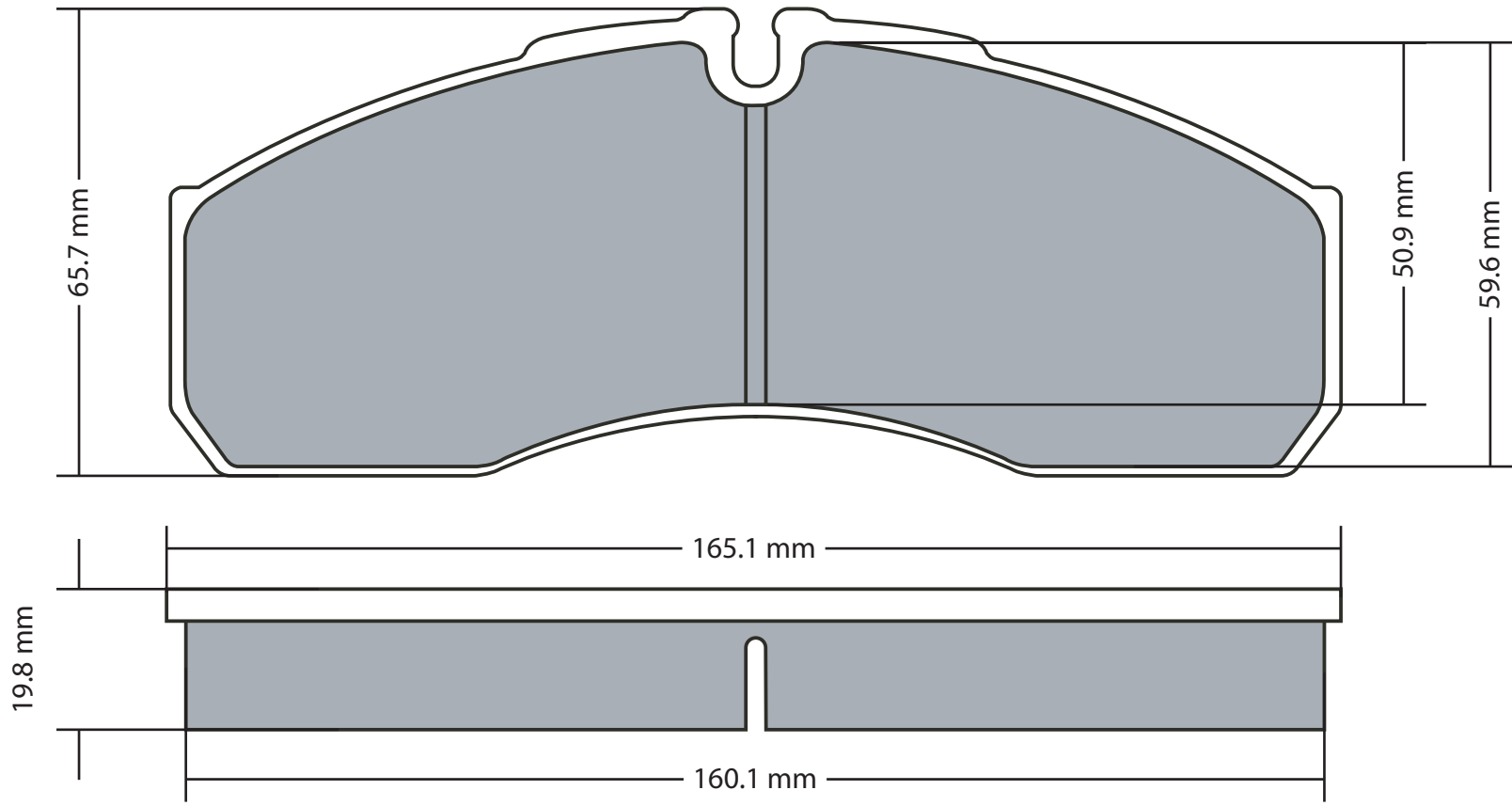

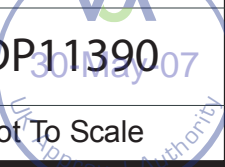
Material Area		Drawn By	Description		Issue No.	Part No.	 DP11390
7703.8 mm			Disc Pad Assembly		1		
Modification	Initial Date	Date	General Tolerance		± 0.25mm		Not To Scale

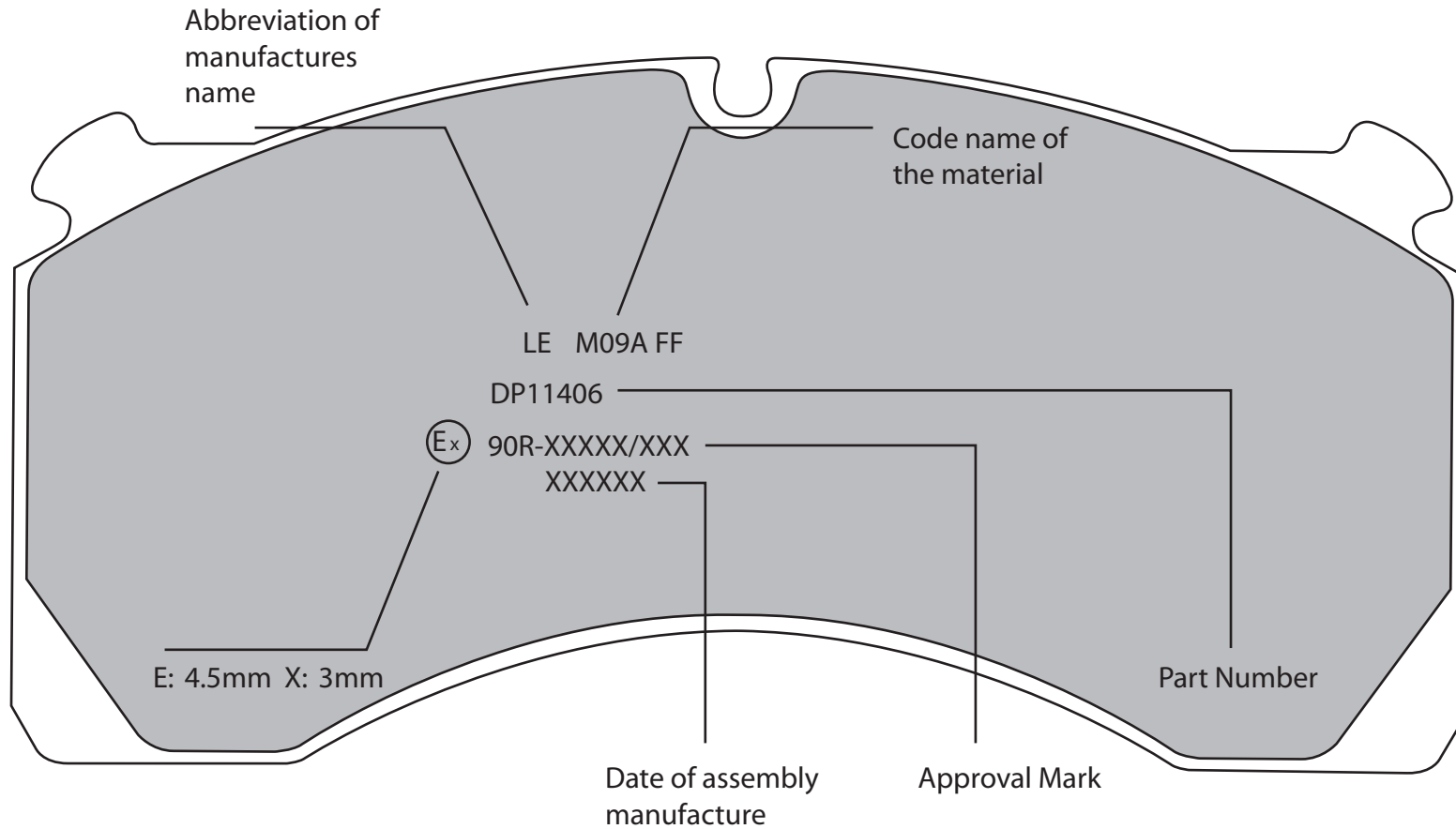

Material Area			Drawn By	Description	Issue No.	Part No.
				Disc Pad Assembly	1	
Modification	Initial Date	Date		General Tolerance	± 0.25mm	Not To Scale

