



**VCA Headquarters**

1 The Eastgate Office Centre  
Eastgate Road  
Bristol, BS5 6XX  
United Kingdom

Switchboard: +44 (0) 117 951 5151  
Direct line: +44 (0) 117 952 4171  
Main Fax: +44 (0) 117 952 4103  
Email: enquiries@vca.gov.uk  
Web: www.vca.gov.uk

THE UNITED KINGDOM VEHICLE APPROVAL AUTHORITY

Rev 1/03



COMMUNICATION CONCERNING THE APPROVAL GRANTED OF  
A REPLACEMENT BRAKE LINING ASSEMBLY OR REPLACEMENT  
DRUM LINING PURSUANT TO ECE REGULATION NO: 90.01

Approval No: 90R-01200/ 3650

1. Applicant's name and address:

Juratek Ltd. Unit 16, Carcroft Enterprise Park, Station Road, Doncaster DN6 8DD

2. Manufacturer's name and address:

3. Make and type of brake lining assembly: DP11277.

4. Make and type of brake lining: LE M09A FF

5. Vehicles/axles/brakes for which the brake lining assembly/drum brake lining type qualifies as original brake lining assembly: Not applicable

6. Vehicles for which the brake lining assembly qualifies as replacement brake lining assembly:

An executive agency of the Department for Transport



7. Submitted for approval on: 4 May 2007
8. Technical Service responsible for approval tests: Vehicle Certification Agency
- 8.1 Date of test report: 3/11/06, 15/11/06, 24/05/06, 17/04/07, 17/04/07.
- 8.2 Number of test reports : VSG078115, VSG173037, VSF066709, VSG177009, VSG177010.
9. Approval GRANTED
10. Place: BRISTOL
11. Date: 4 JUNE 2007
12. Signature:  A. W. STENNING  
Head of Product Certification
13. Annexed to this communication is a list of documents in the approval file deposited at the administrative services having delivered the approval and which can be obtained upon request.

VSG177017



04/05/07	<b>VCA Job No</b>	VSG177017
----------	-------------------	-----------

Dear Claire,

Please find enclosed the necessary documentation for you to submit applications for approval for various brake lining assemblies DP11277 in LE M09A FF material pursuant to ECE Regulation No. 90/1. This application is on behalf of Juratek Ltd and cross-references to our DP LE M09A FF application details. We would like the application made to the VCA; I have addressed the formal letter of application accordingly.

The documents contained are: -

1. Formal letter of application
2. Manufacturers declarations
3. Lab test results :-
  - Friction test results
  - Shear test results
  - Compressibility test results
4. Vehicle fitment details
5. Disc pad assembly drawings
6. General disc pad marking drawing

**Please note: Allocated with E11 90R-01200/3650**

**This approval is based on VSG078115, VSG173037 and VSF066709 plus additional OE Materials testing on VSG177009 and VSG177010.**

Yours sincerely,



Susan Owens  
Q.B.T.



04/05/07	<b>VCA Job No</b>	VSG177017
----------	-------------------	-----------

Vehicle Certification Agency  
 1 Eastgate Office Centre  
 Eastgate Road  
 Bristol  
 BS5 6XX

**Letter of application for an approval pursuant to ECE Regulation No. 90/1**

Dear Sirs,

Herewith we apply for an approval for our brake lining assembly pursuant to ECE Regulation No. 90/1.

Applicants name and address:

Juratek Ltd. Unit 16, Carcroft Enterprise Park, Station Road, Doncaster DN6 8DD

Manufacturers name and address:

Make and type of brake lining                      LE M09A FF  
 Make and type of brake lining assembly        as listed below

Assembly Number	Assembly Contains...(see enclosed drawings)	Material Code
DP11277	2 pairs of pads	LE M09A FF



04/05/07	<b>VCA Job No</b>	VSG177017
----------	-------------------	-----------

For vehicles / axles / brakes for which the lining assembly qualifies as replacement brake lining assembly, see following application list.

Assembly Number	Equivalent to	Also supplied as Assembly Number
DP11277 LE M09A FF	Equivalent to	
	Equivalent to	

Yours faithfully



Susan Owens  
Q.B.T.



04/05/07	VCA Job No	VSG177017
----------	------------	-----------

## Manufacturer's Declaration

for granting of Approval for replacement brake lining according to ECE Regulation No. 90/1.

We, the company

declare herewith that

Replacement pad assemblies DP11277 LE M09A FF

are produced in our factory

We certify that no application has been made regarding this permission/approval by us or by companies appointed by us in countries which as contract parties would also be entitled to grant permission/approval.

We are aware of the following: -

A type marking of vehicles/vehicle components of the above mentioned type with the officially assigned approval mark can only be granted if the products have been manufactured in the above mentioned factory or at one of our listed and approved manufacturing sites, and if they comply with the official approval documents.

Companies manufacturing products for our company or under license may not use the officially assigned approval mark for vehicles/vehicle components produced at their factories unless they are listed as an approved manufacturing site, and fully comply with our quality procedures.

A marking of vehicles/vehicle components of the above mentioned type with different factory or trade marks but the same approval mark is only permissible if written consent has been obtained from the Vehicle Certification Agency.



Susan Owens  
Q.B.T.



04/05/07	VCA Job No	VSG177017
----------	------------	-----------

### Friction test results

Conducted in accordance with Annex 8, of ECE Regulation No. 90 Rev1 including supplement 2 to the 01 series of amendments. (TRANS/SC1/WP29/GRRF/R90 Rev 1).

Type of assembly: Part Number DP1143 in material LE M09A FF  
(Previously agreed single test reference)

Type of test:	Constant torque (para. 2.2.2.2)
$\mu_{op: 1}$	0.37
$\mu_{op: 2}$	0.39
$\mu_{min}$ :	0.29
$\mu_{max}$ :	0.41

Test dates: 11/02/2007



Susan Owens  
Q.B.T.



04/05/07	VCA Job No	VSG177017
----------	------------	-----------

### Bench tests

Manufacturer:			
Type of brake lining assy:	DP1143 LE M09A FF	Page	1/2

1. Shear strength test<sup>1</sup>  
(5.3.2.1 of ECE Regulation No. 90 Rev 1)

- Sample

Type of assembly: DP1143 LE M09A FF  
Shear area [cm<sup>2</sup>]: 46.24

- Shear strength measured

Mean value [N/cm<sup>2</sup>]: 564.4  
Required [N/cm<sup>2</sup>]: 250

Test date: 10/02/2007

1) Test procedure according to ISO Standard 6312 (2001)



Susan Owens  
Q.B.T.





04/05/07	VCA Job No	VSG177017
----------	------------	-----------

Manufacturer:			
Type of brake lining assy:	LE M09A FF	Page	2/2

2. Compressibility test<sup>2</sup>  
(5.3.2.2 of ECE Regulation No. 90 Rev 1)

- Sample

Type: III  
 Type of assembly: LE M09A FF  
 Thickness,  $d_0$  (nominal value) [mm]: 15.0  
 Pad area [cm<sup>2</sup>]: 46.24  
 Ram dia (corresponding to caliper piston dia) [mm]: 60

- Compressibility at specific surface pressure of 8000 kPa

Measured at ambient temperature

Mean value:  $\frac{d_4 - d'_3}{d_0} = 0.45\%$

Required:  $\leq 2\%$

Measured at 400°C

Mean value:  $\frac{d_4 - d'_3}{d_0} = 1.49\%$

Required:  $\leq 5\%$

Test dates: 10/02/2007

2) Test procedure according to ISO Standard 6310 (2001)



Susan Owens  
Q.B.T.





MAKE	MODEL 1	MODEL 2	MODEL 3	MODEL 4	MODEL 5	F/R	D	A	T	E	OE Caliper Manufacturer	S/V Dr	Disc / Drum / Dia	Max Th Disc / Shoe Width
DP11277	DISCOS	Trailers	with Knorr Brakes	17.5" wheels	SB 5000		01	99			Knorr	V		
DP11277	DISCOS	Trailers	TZ Series	17.5" wheels	SB 5000		01	99			Knorr	V		
DP11277	GRANNING LYNX	SB 5000	17.5" wheels				01	00			Knorr	V		
DP11277	KNORR - BREMSEN	SB 5000	17.5" wheels								Knorr	V		
DP11277	MERCEDES	Atego	712 --> 823 models	except all wheel #17.5" wheels		F	01	98			Knorr	V	335	34
DP11277	MERCEDES	Atego	712 --> 823 models	except all wheel #17.5" wheels		R	01	98			Knorr	V	335	34
DP11277	MERCEDES	Atego	917 --> 1023 models	except all wheel #17.5" wheels		F	01	98			Knorr	V	335	34
DP11277	MERCEDES	Atego	917 --> 1023 models	except all wheel #17.5" wheels		R	01	98			Knorr	V	335	34
DP11277	SAE DUPILLIER	with Knorr brakes	SB 5000				01	99			Knorr	V		
DP11277	TRAILERS	with Knorr brakes	SB 5000	17.5" wheels		R	01	98			Knorr	V		



CALIPER ACTUATION	BRAKING SPLIT F/R, DIAG or H / I	CALIPER PAD		HERST NUMBER	TYP / SCHL NUMBER	MAX SPEED Km/h	80% V MAX Km/h	VEHICLE / AXLE WEIGHT		ENERGY FACTOR .5 MV 2	MAXIMUM ROLLING RADIUS	INERTIA UNLADEN	VEHICLE INERTIA	
		PISTON DIA	FRICTION AREA mm^2					UN-LADEN	LADEN				LADEN	AXLE INERTIA LADEN
Air	F/R					90	72	5900	15292800	0.365	0	125.7644	216.1575625	
Air	F/R					90	72	5900	15292800	0.365	0	125.7644	216.1575625	
Air	F/R					90	72	5900	15292800	0.365	0	125.7644	216.1575625	
Air	F/R					90	72	5900	15292800	0.365	0	125.7644	216.1575625	
Air	F/R			0708 / 0709/ 0710		90	72	7500	19440000	0.365	0	384.6871875	142.8838125	
Air	F/R			0708 / 0709/ 0710		90	72	7500	19440000	0.365	0	159.87	150.2111875	
Air	F/R			0708 / 0709/ 0710		90	72	10500	27216000	0.389	0	611.7151425	170.6144275	
Air	F/R			0708 / 0709/ 0710		90	72	10500	27216000	0.389	0	254.21928	245.5183225	
Air	F/R					90	72	5900	15292800	0.365	0	125.7644	216.1575625	
Air	F/R					90	72	5900	15292800	0.389	0	245.5183225	245.5183225	

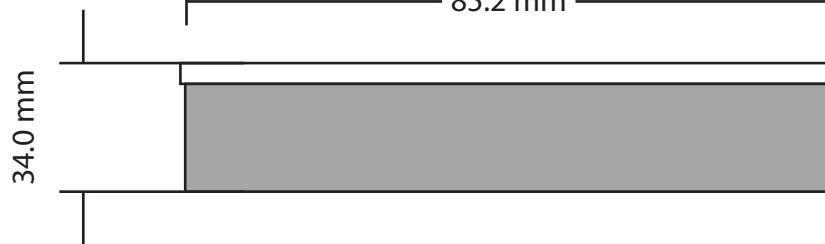
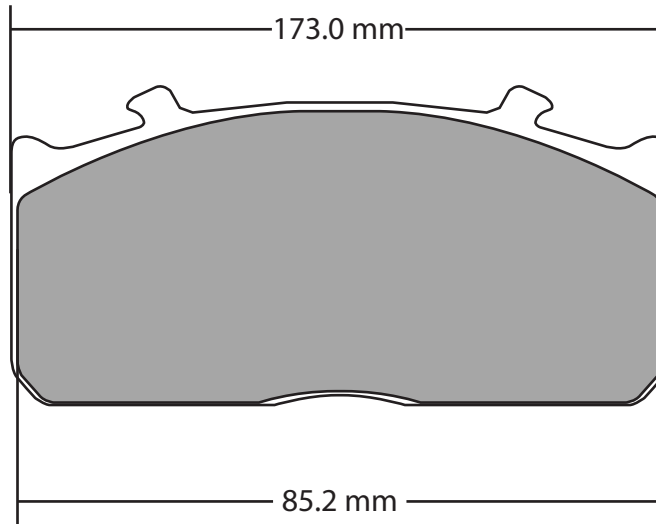
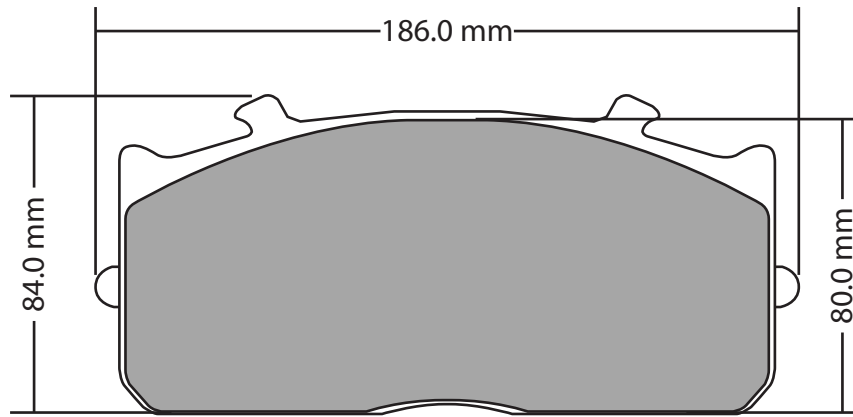



Material Area			Drawn By	Description	Issue No.	Part No.	 <b>DP11277</b> <small>04-Jun-07</small>
2932.8 mm				<b>Disc Pad Assembly</b>	<b>1</b>		
Modification	Initial Date	Date		General Tolerance	<b>± 0.25mm</b>		Not To Scale



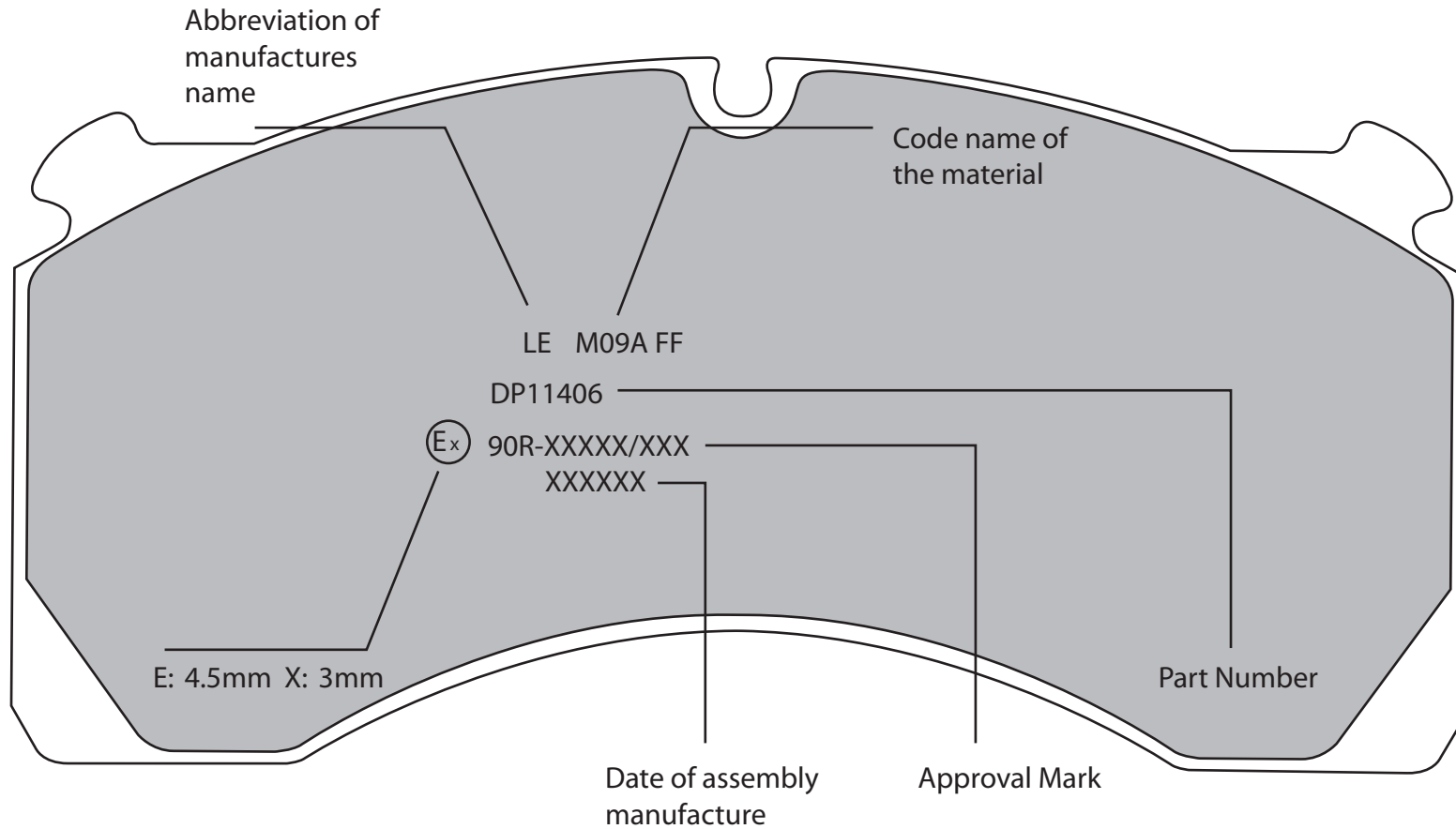

Material Area			Drawn By	Description	Issue No.	Part No.
				<b>Disc Pad Assembly</b>	<b>1</b>	
Modification	Initial Date	Date		General Tolerance	<b>± 0.25mm</b>	Not To Scale

