

NAME	CS-J017 Camshaft Sensor	NO	CS-1-3-759
-------------	--------------------------------	-----------	------------

Picture 	Plug 	Waveform 
---	--	--

Drawing and Dimension

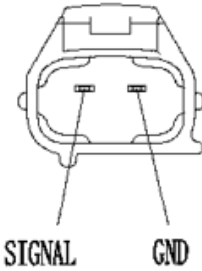
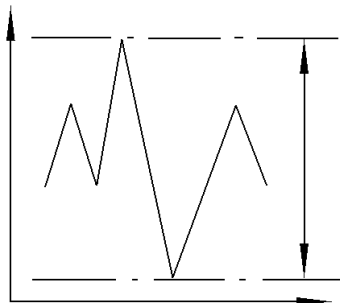
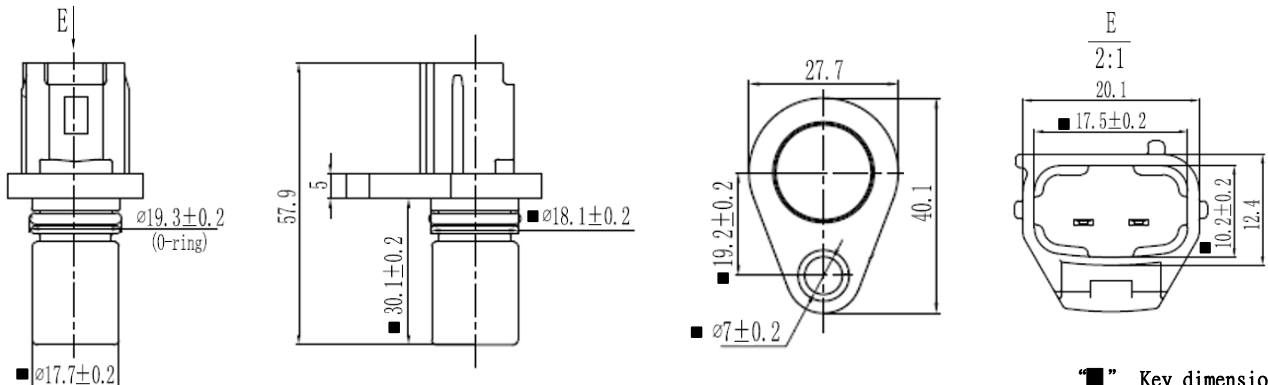

"■" Key dimension

TYPE : Hall Magnetic

Parameter	SYMBOLS	MIN.	TYP.	MAX.	UNITS
Resistance (25°C)	R	950	1080	1290	ohm
Inductance@1KHz	L	495	600	665	mH
Working Voltage	V	N/A	N/A	N/A	V
Detecting range	Air Gap	N/A	1	N/A	mm
Magnetic field direction SFS=South facing sensor NFS=North facing sensor		NFS	NFS	NFS	
Duty ratio(t1/T)	Duty	N/A	N/A	N/A	%
Temperature	To	-30	25	125	°C
Reference Teeth		N/A	24-2	N/A	
Output Voltage (600RPM,1mm)	Vp-p	16	20	24	V

2020.08.27		1	呂漢榮	王亮	黃鵬	MOBILETRON
Date of first edition	Date of revised edition	edition	Manuscript	Review	Approval	Sep.01.2020
						Release