

**Jaeger FLEX
2in1**

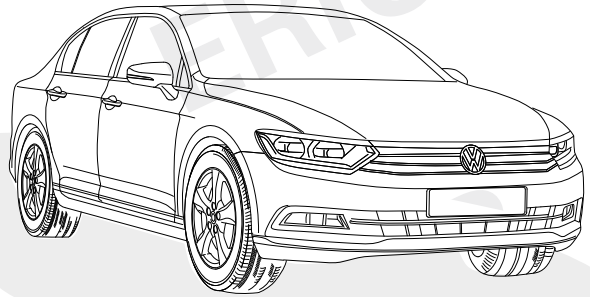
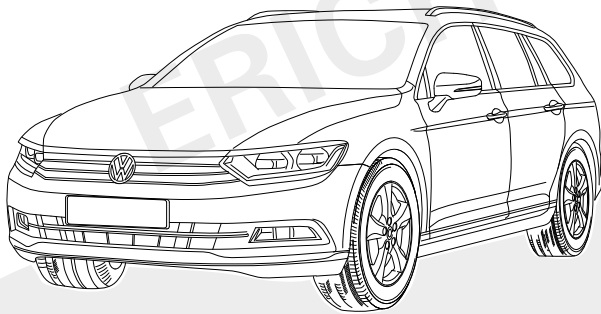

**VW Passat B8 Variant
VW Passat B8 Limousine**

11/14 >>

11/14 >>

737343

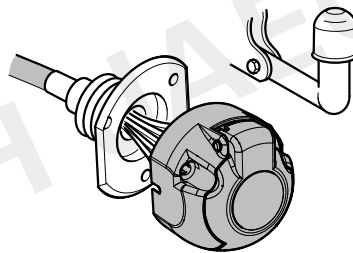

7-PIN

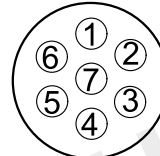

ISO 1724

- | | | | |
|--------------|------------------------------------|--------------|--|
| (D) | Einbauanleitung | (PL) | Instrukcja montażu |
| (GB) | Installation instructions | (TR) | Montaj talimatı |
| (F) | Consignes de montage | (H) | Beépítési útmutató |
| (NL) | Montagehandleiding | (HR) | Upute o ugradnji |
| (DK) | Montagevejledning | (BUL) | Инструкция за монтаж |
| (N) | Monteringsinstruksjon | (RO) | Instrucțiuni de montaj |
| (S) | Installationsanvisning | (RU) | Инструкция по монтажу и установке |
| (FIN) | Asennusohje | (LT) | Montavimo informacija |
| (I) | Istruzioni per il montaggio | (LV) | Iemontēšanas pamācība |
| (E) | Instrucciones de montaje | (EST) | Paigaldusjuhend |
| (P) | Instruções de montagem | (SLO) | Navodilo za vgradnjo |
| (GR) | Οδηγίες εγκατάστασης | (SK) | Montážny návod |
| (CZ) | Návod k montáži | | |

KIT

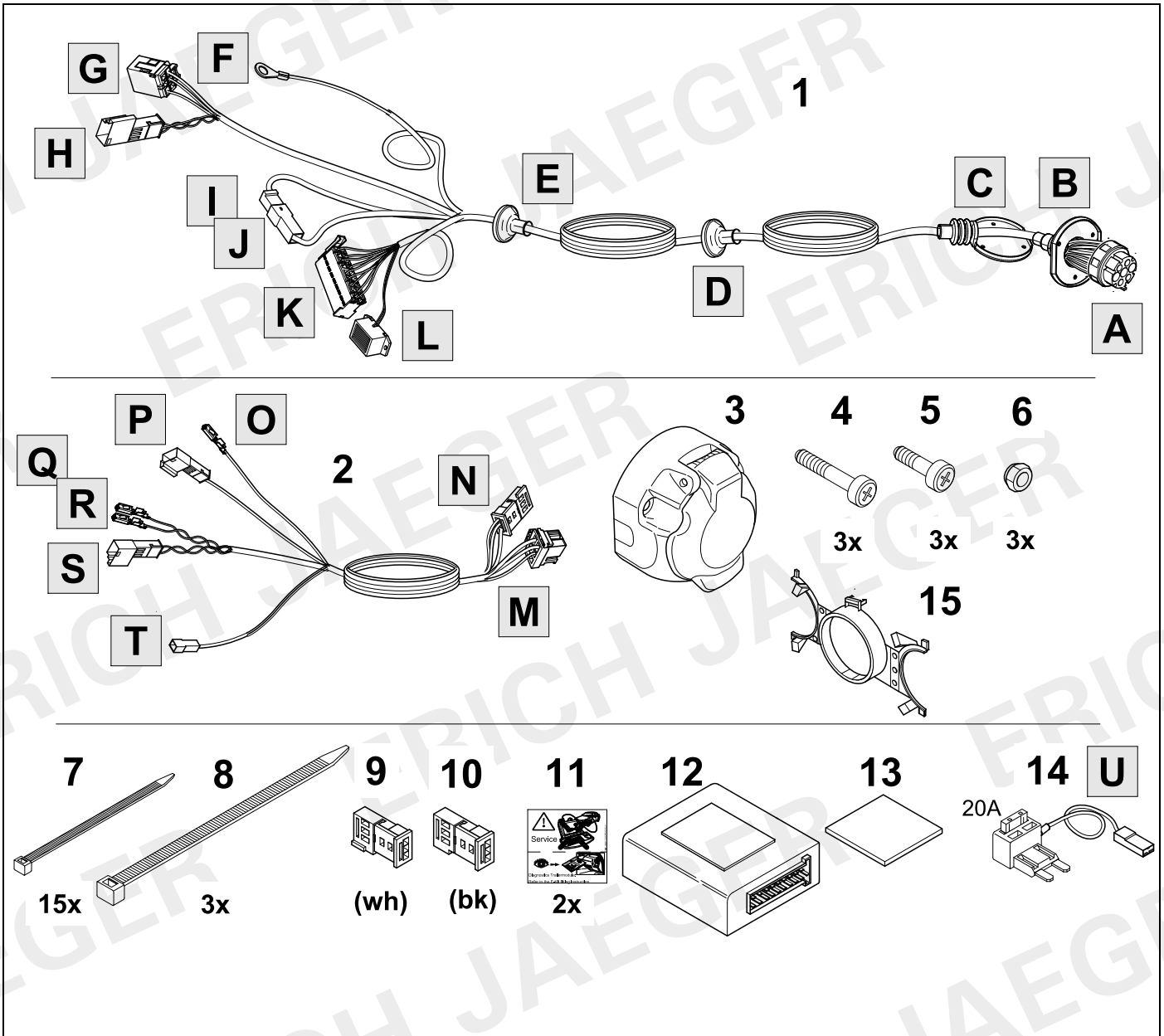

TOOLS

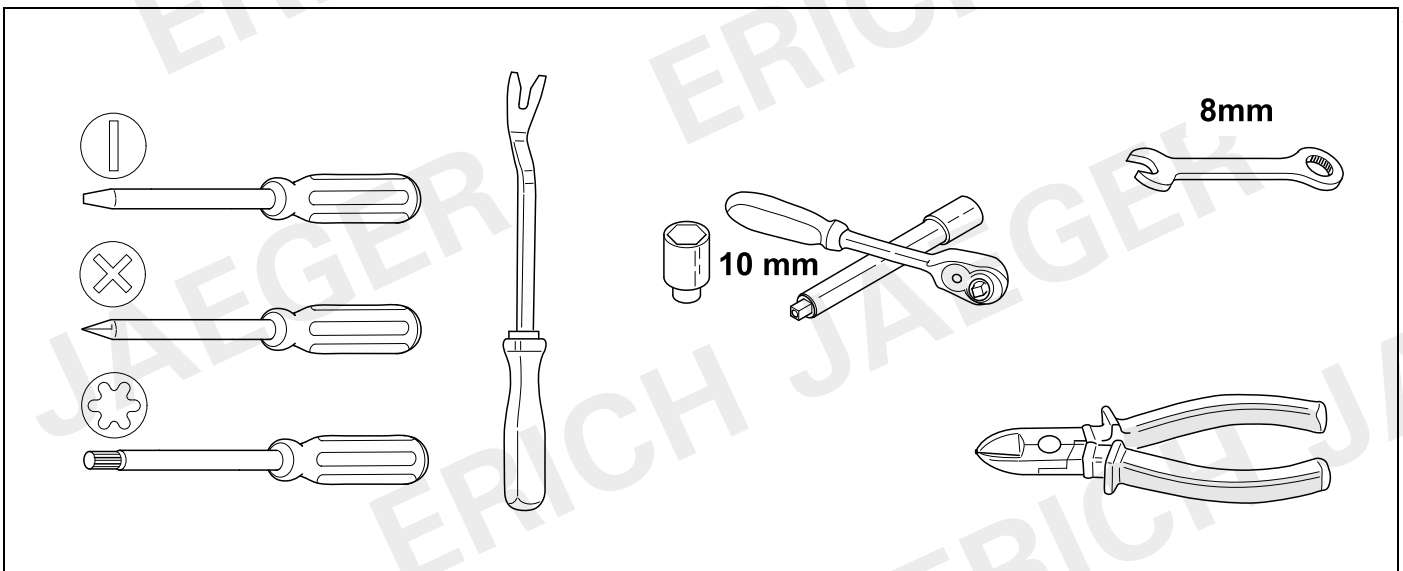

1

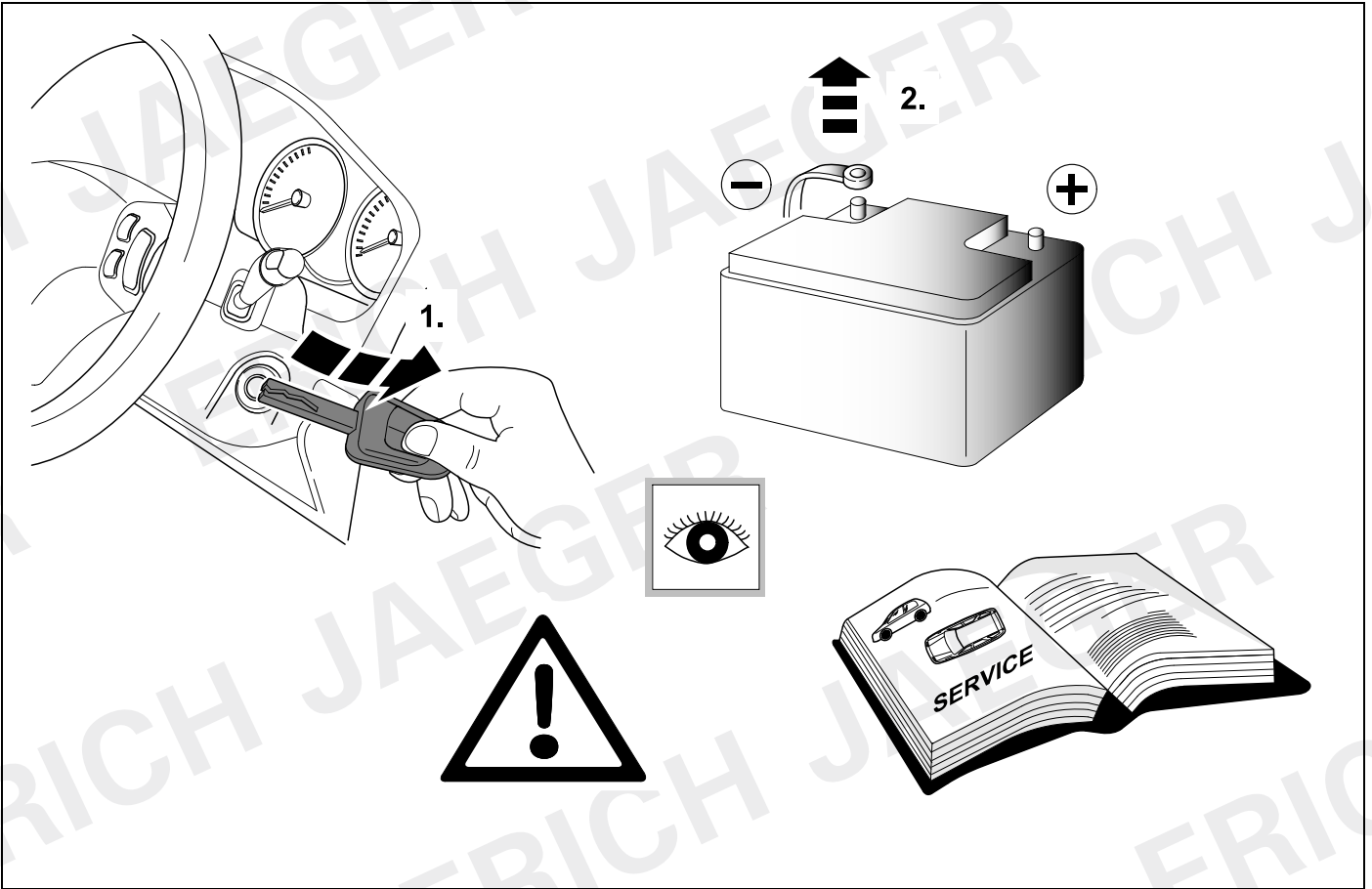

2 REMOVE

VARIANT

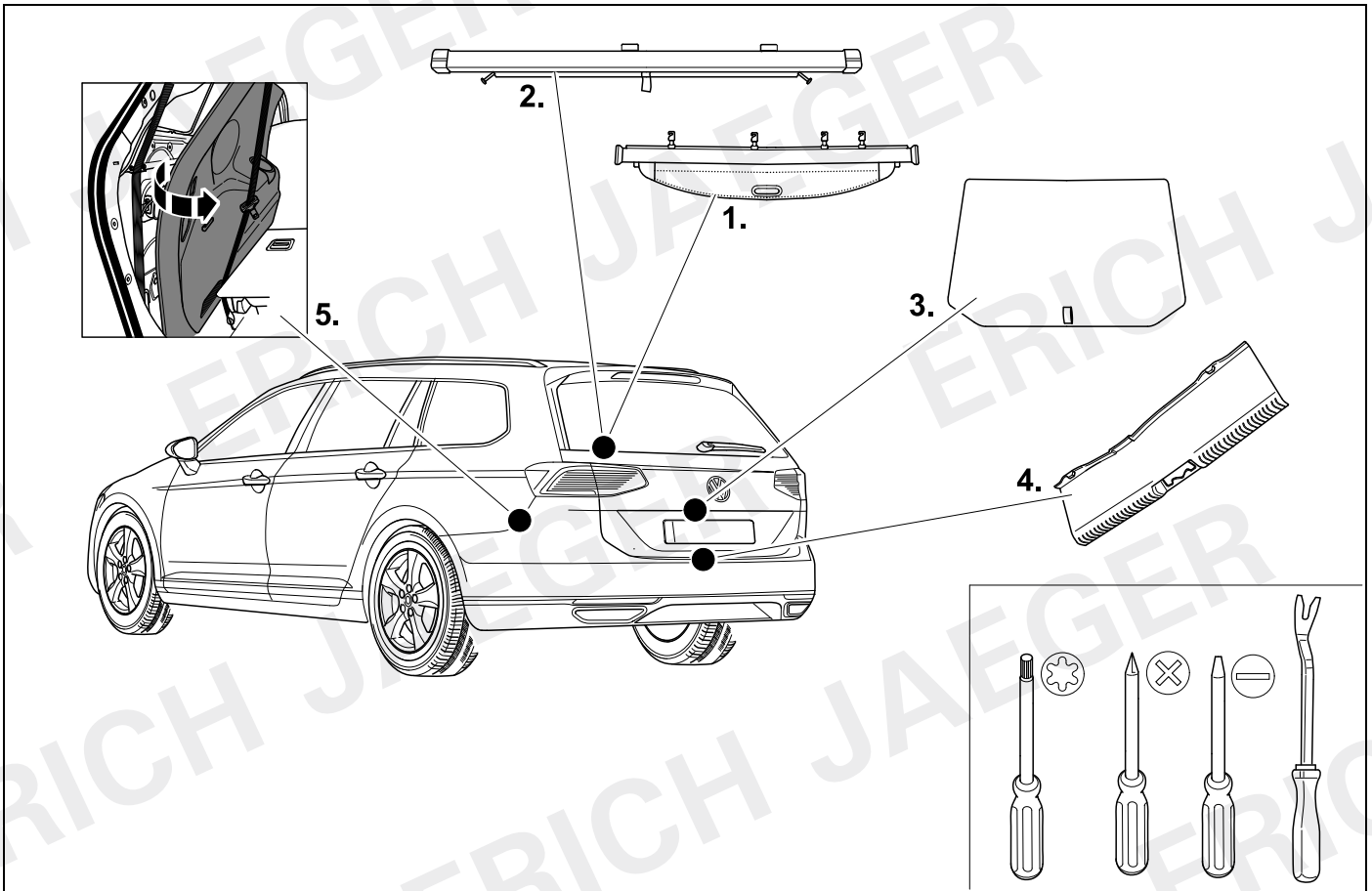

3 REMOVE

LIMOUSINE

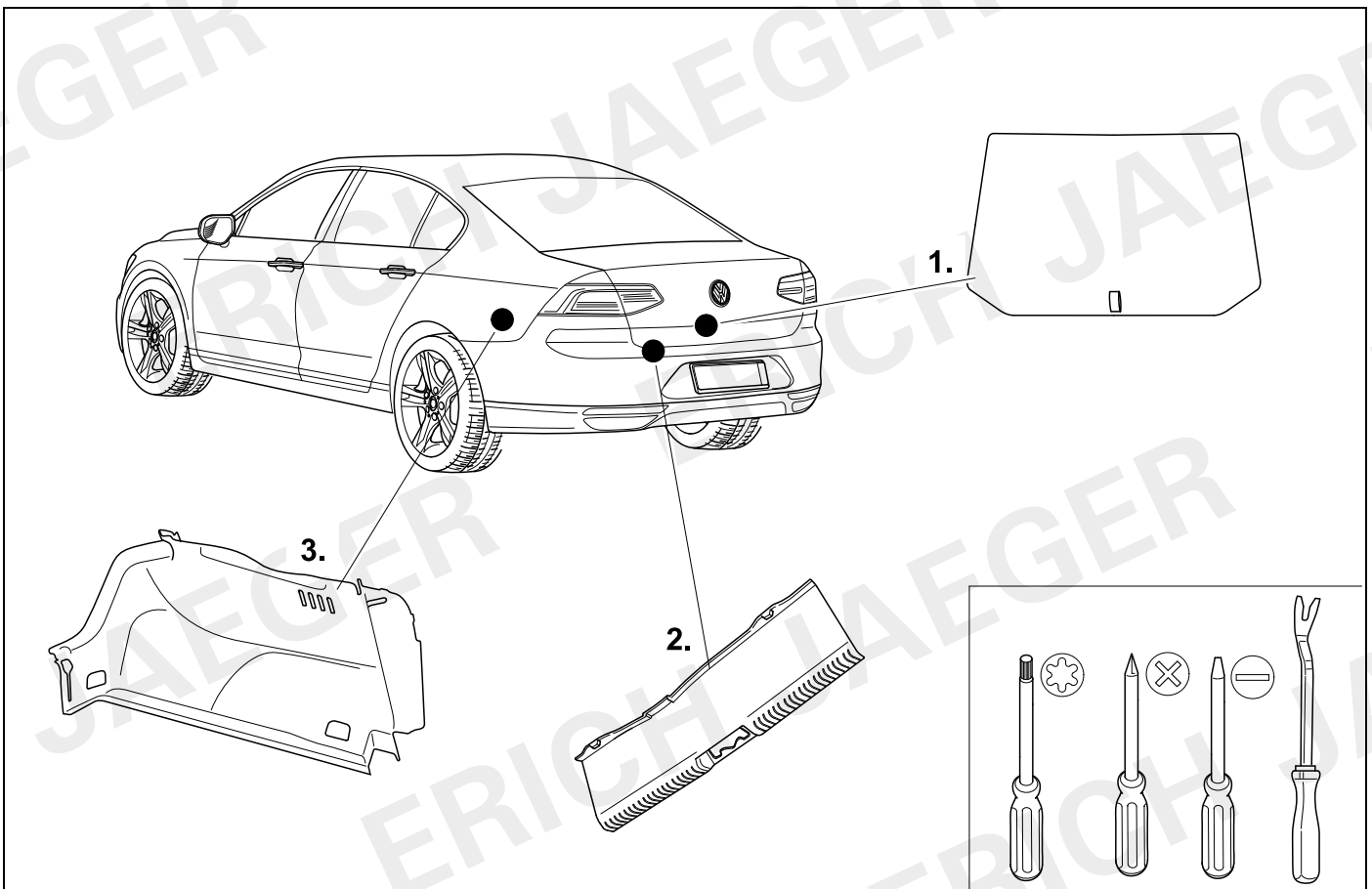

4

VARIANT

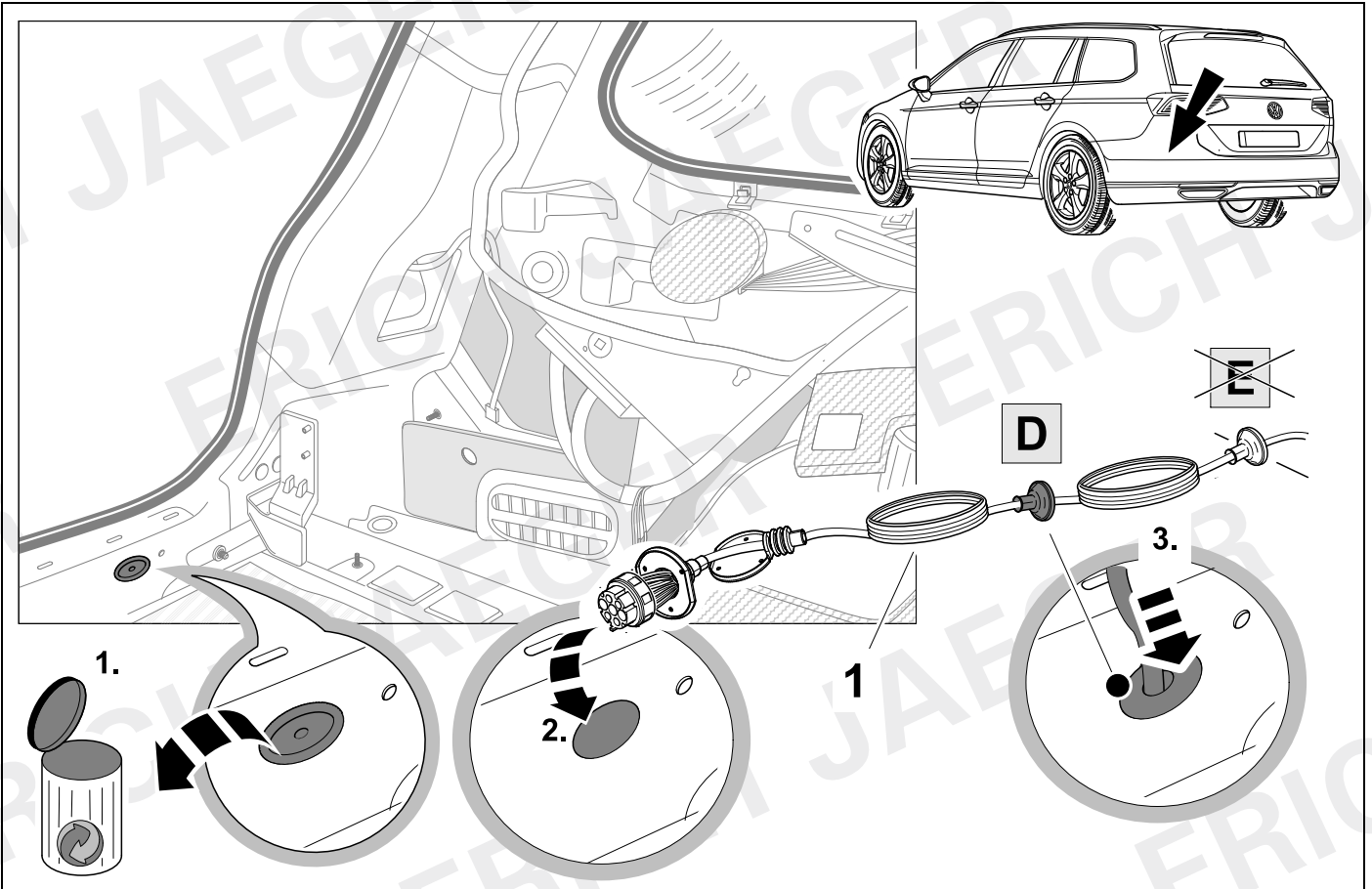

5

LIMOUSINE

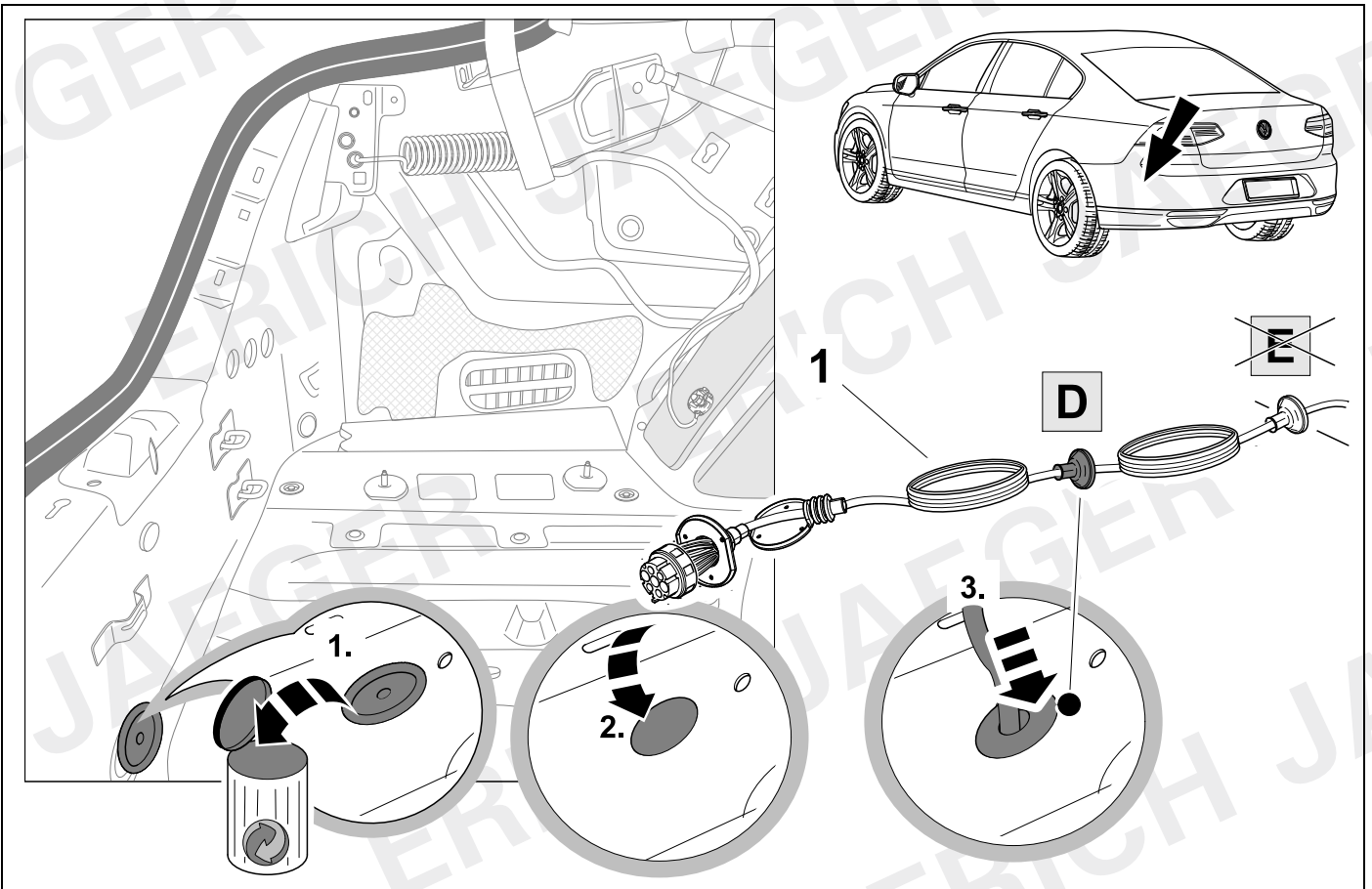

6

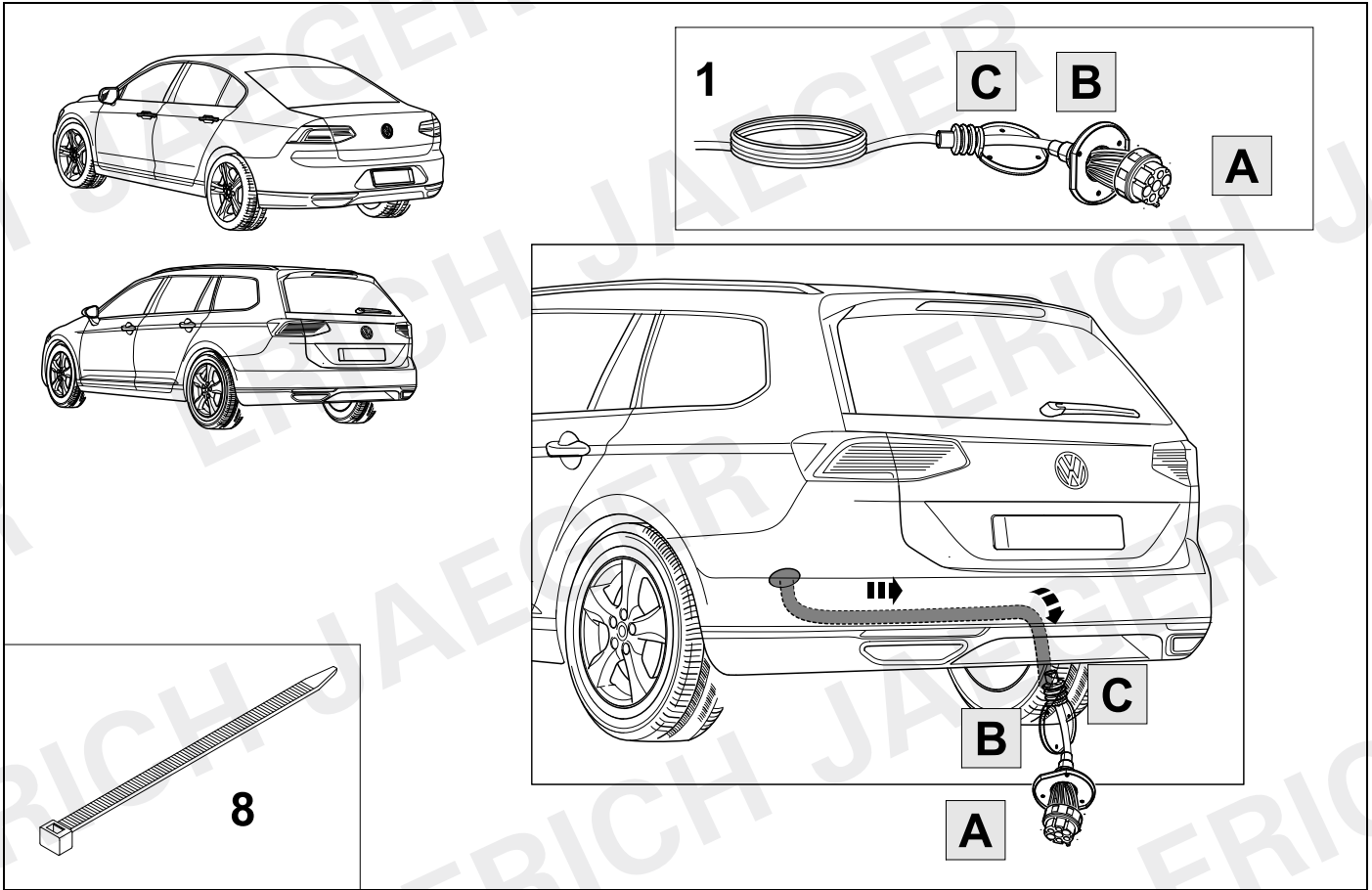

7

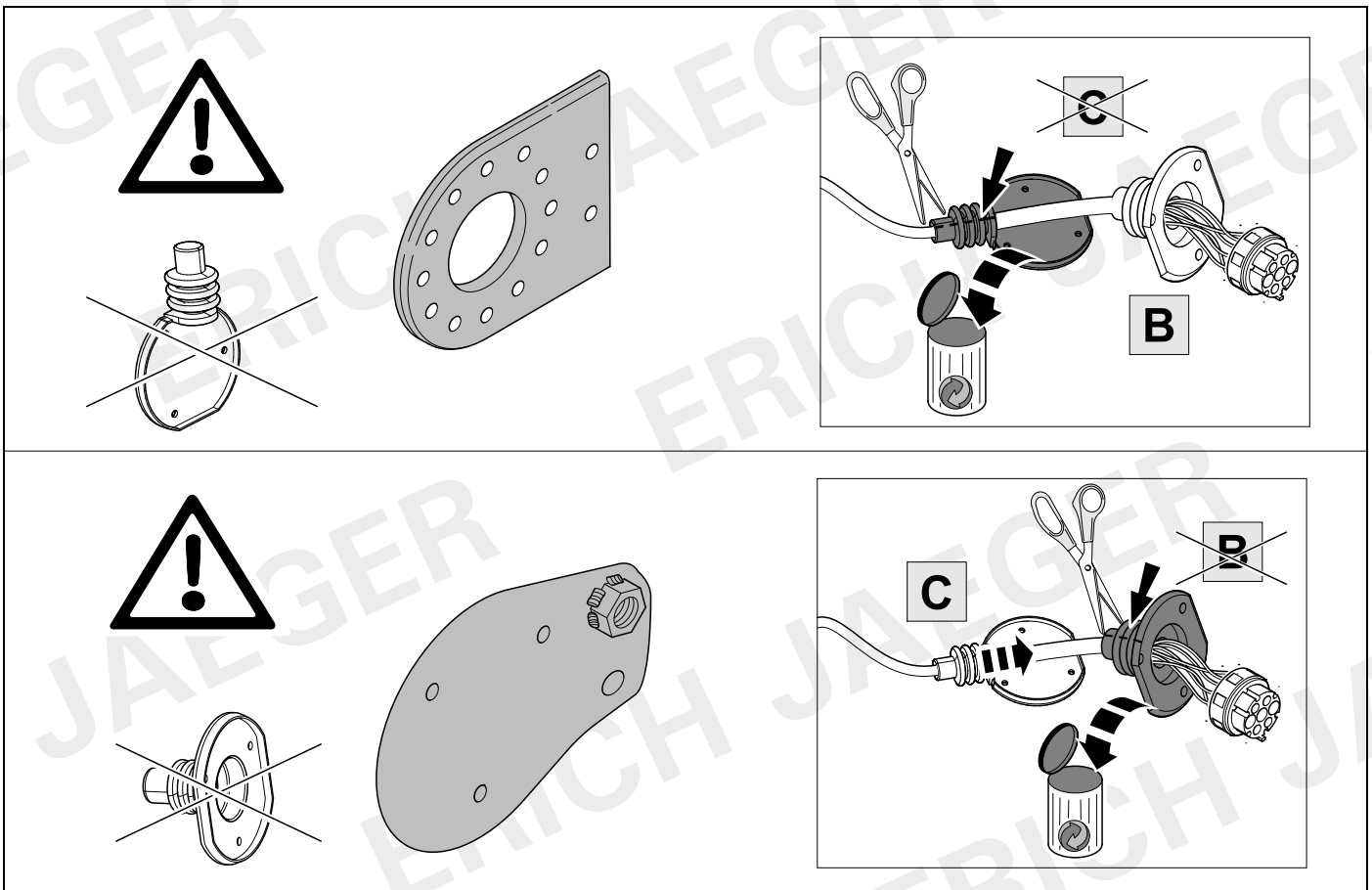

8



10

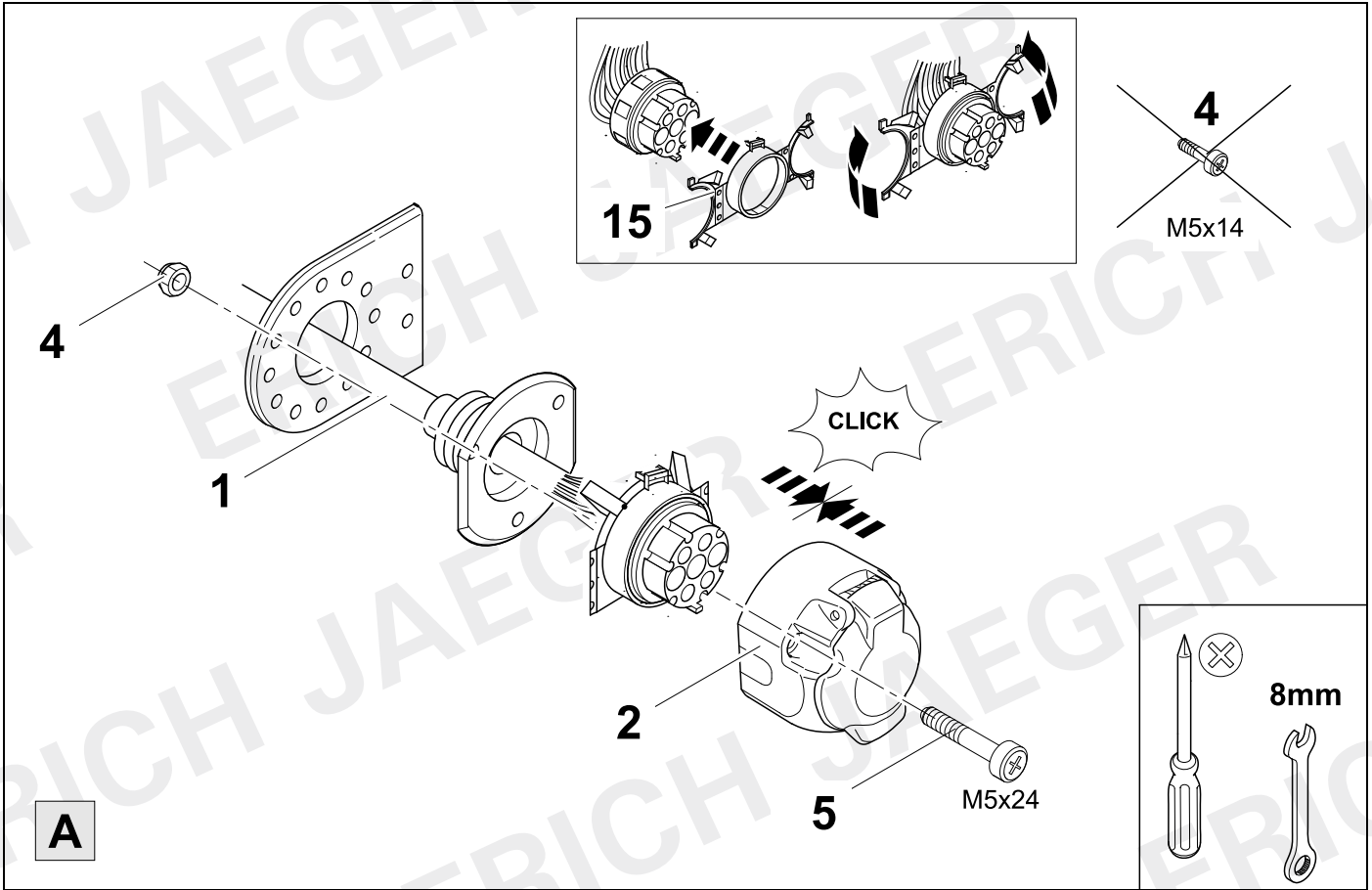

9



10

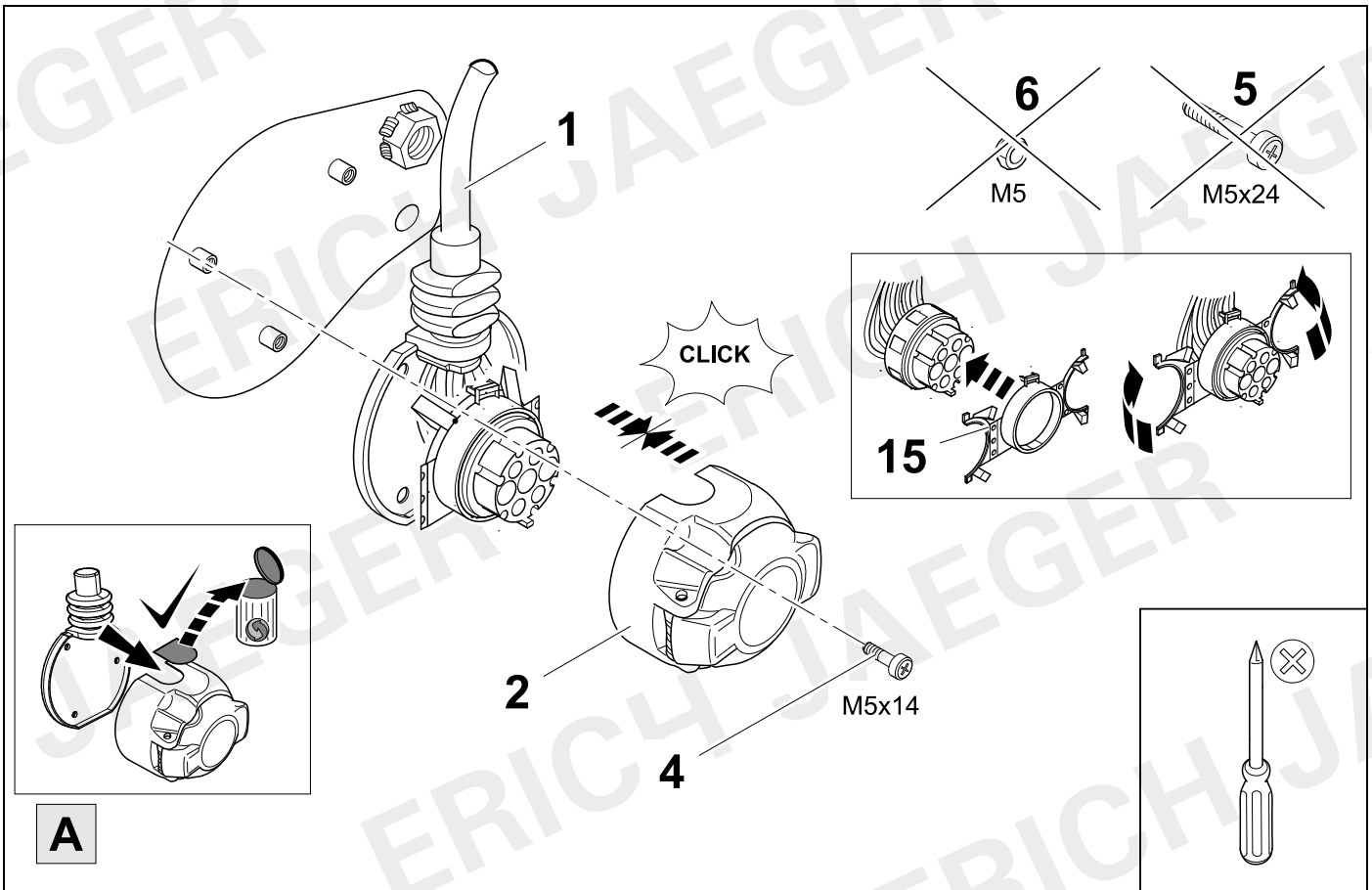

10



11

1/L	bk/wh	
2/54g	gy	
3/31	wh/bn	
4/R	bk/gn	
5/58R	gy/rd	
6/54	bk/rd	
7/58L	gy/bk	

11	bk	wh	gy	gn	rd	bu	ye	bn	pu	or	no
(D)	schwarz	weiß	grau	grün	rot	blau	gelb	braun	violett	orange	nicht belegt
(GB)	black	white	grey	green	red	blue	yellow	brown	purple	orange	not occupied
(F)	noir	blanc	gris	vert	rouge	bleu	jaune	brun	violet	orange	inutilisé
(NL)	zwart	wit	grijs	groen	rood	blauw	geel	bruin	violet	oranje	niet aangesloten
(DK)	sort	hvid	grå	grøn	rød	blå	gul	brun	violet	orange	ikke anvendt
(N)	svart	hvit	grå	grønn	rød	blå	gul	brun	fiolett	oransje	ikke i bruk
(S)	svart	vit	grå	grön	röd	blå	gul	brun	violett	orange	ej använd
(FIN)	musta	valkoinen	harmaa	vihreä	punainen	sininen	keltainen	ruskea	violetti	oranssi	ei varattu
(I)	nero	bianco	grigio	verde	rosso	blu	giallo	marrone	viola	arancione	libero
(E)	negro	blanco	gris	verde	rojo	azul	amarillo	marrón	violeta	anaranja-do	no ocupado
(P)	preto	branco	cinzento	verde	vermelho	azul	amarelo	castanho	violeta	laranja	não ocupado
(GR)	μαύρος	λευκός	Γκρι	πράσινος	κόκκινος	μπλε	κίτρινος	καφέ	Μωβ	πορτοκαλί	δεν είναι κατ εισημμένος
(PL)	czarny	biały	szaro	zielony	czerwony	niebiesko	żółty	brazowy	fioletowy	pomarańczowy	wolny
(CZ)	černý	bílý	šedý	zelený	červený	modrý	žlutý	hnědý	fialový	oranžový	neobsazen
(TR)	siyah	beyaz	gri	yeşil	kırmızı	mavi	sarı	kahverengi	mor	portakal rengi	boş
(H)	fekete	fehér	szürke	zöld	piros	kék	sárga	barna	ibolyakék	narancssárga	nem foglalt
(HR)	crno	bijelo	sivo	zeleno	crveno	plavo	zuto	smeđe	ljubičasto	narandžasto	nije zauzeto
(BUL)	черен	бял	сив	зелен	червен	син	жълт	кафяв	виолетов	оранжев	свободно
(RO)	negru	alb	gri	verde	roșu	albastru	galben	maro	violet	portocaliu	liber
(RU)	черный	белый	серый	зеленый	красный	голубой	жёлтый	коричневый	пурпурный	оранжевый	свободно
(LT)	juoda	balta	pilka	žalia	raudona	mėlyna	geltona	ruda	purpurinė	oranžinė	laisva
(LV)	melna	balta	pelēka	zaļa	sarkana	zila	dzeltena	brūna	purpur-sarkana	oranža	brīvs
(EST)	must	valge	hall	roheline	punane	sinine	kollane	pruun	purpur-punane	oraanž	vaba
(SLO)	črna	bela	siva	zelena	rdeča	modra	rumena	smeđ	vijoličast	oranžen	ni zasedeno
(SK)	čierny	biely	šedý	zelený	červený	modrý	žltý	hnědý	fialový	pomaraňový	neobsadený

12

VARIANT

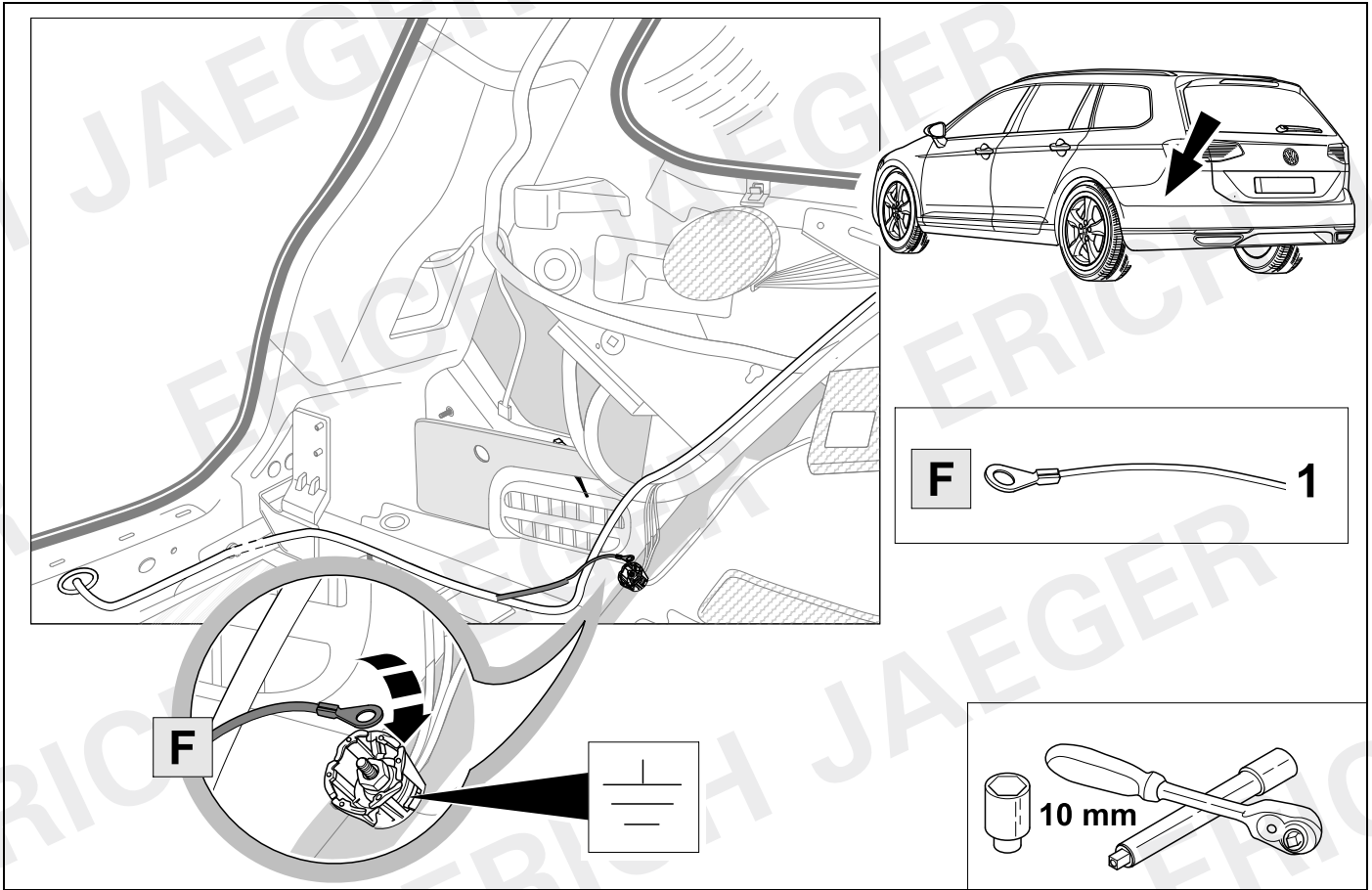

13

LIMOUSINE

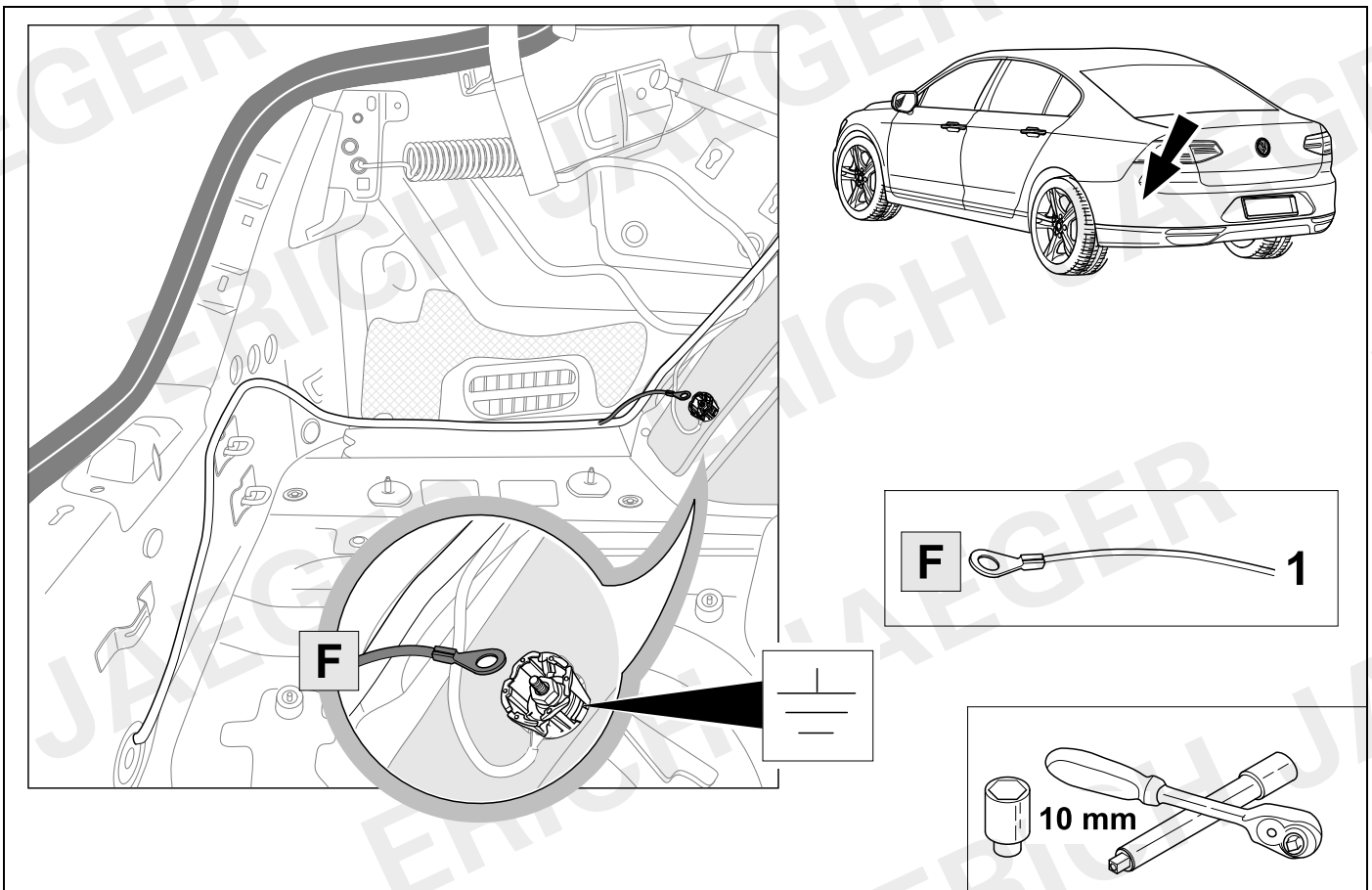

14



11

Fahrzeuge mit Anhängervorbereitung
Vehicles with trailer preparation

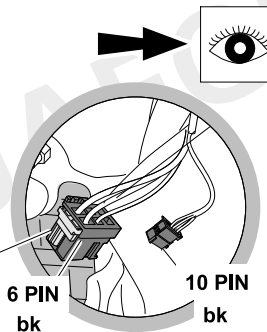
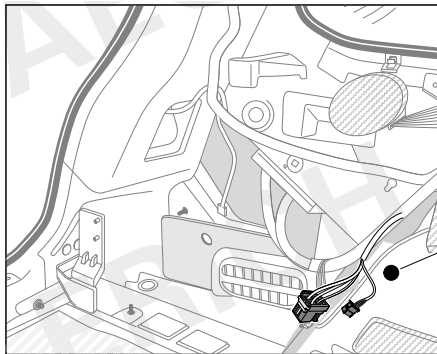

OPTION 1

15



22

37



52

Fahrzeuge ohne Anhängervorbereitung
Vehicles without trailer preparation

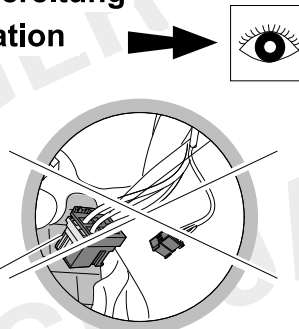
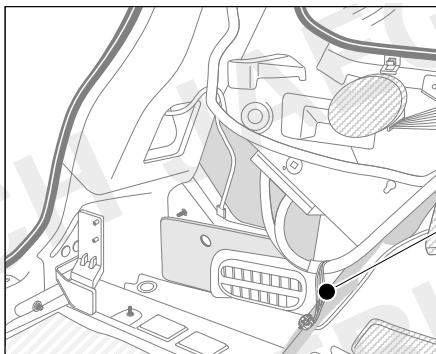

OPTION 2

23



52

15



11

OPTION 1

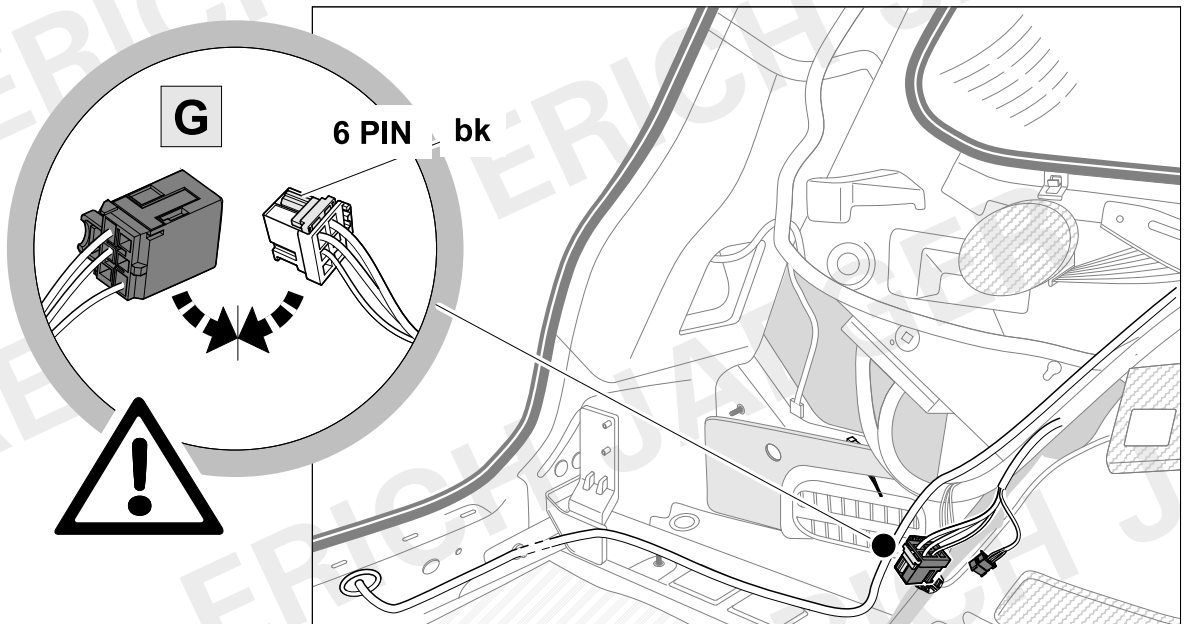
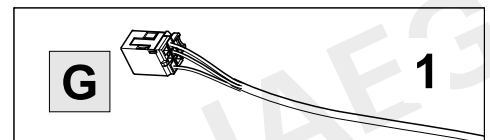
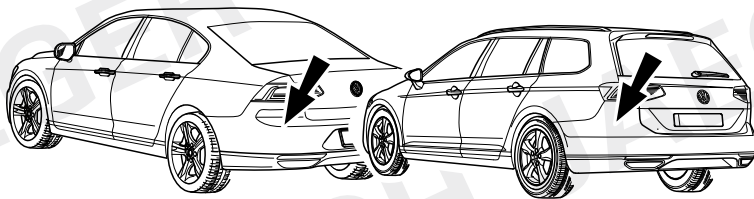

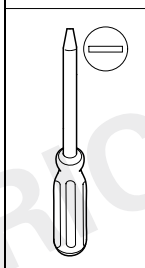
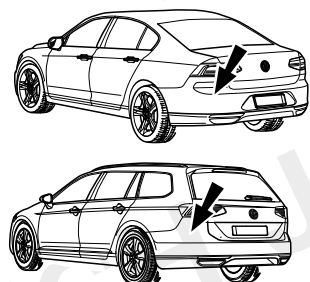
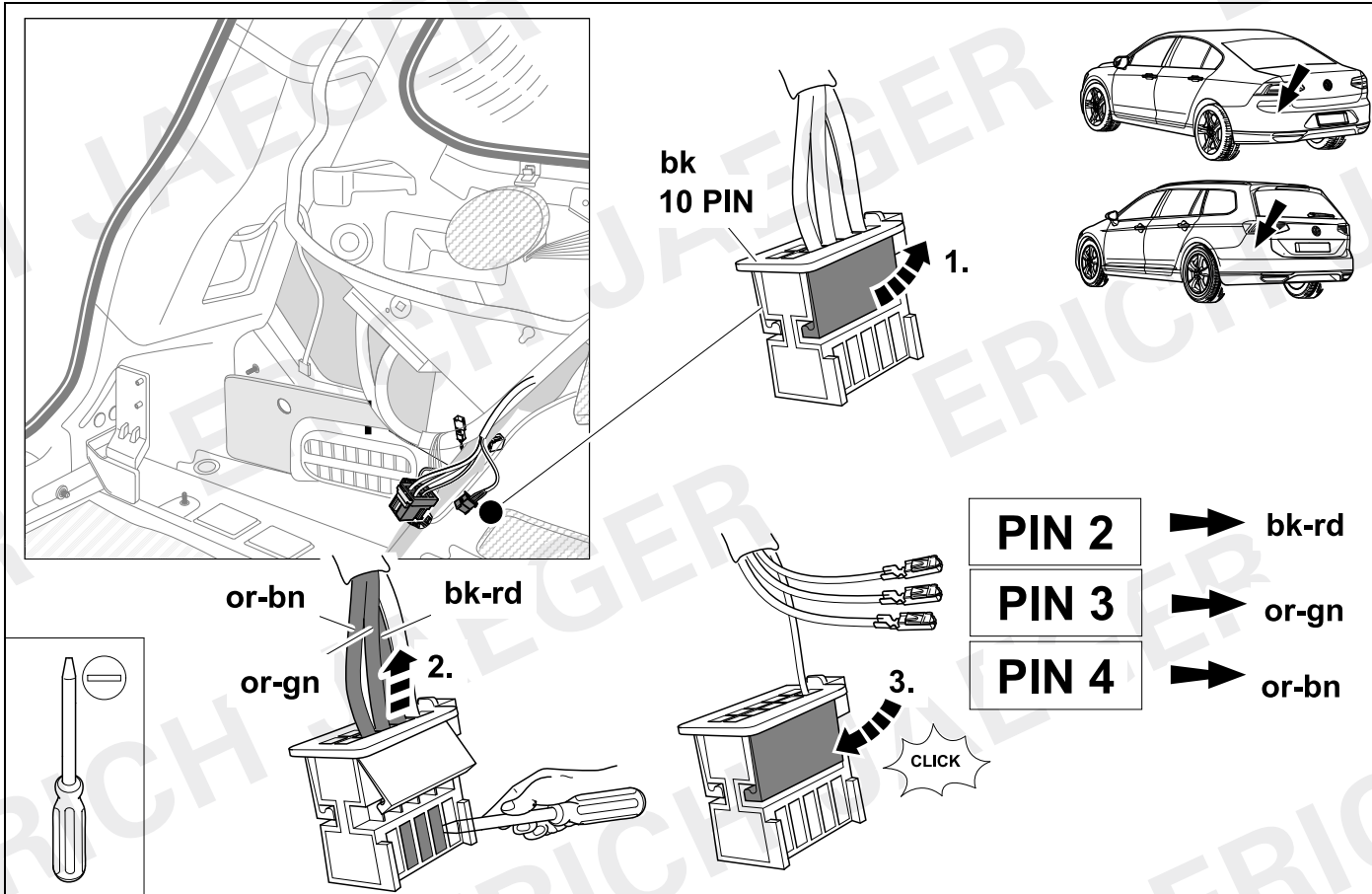

17



11

OPTION 1

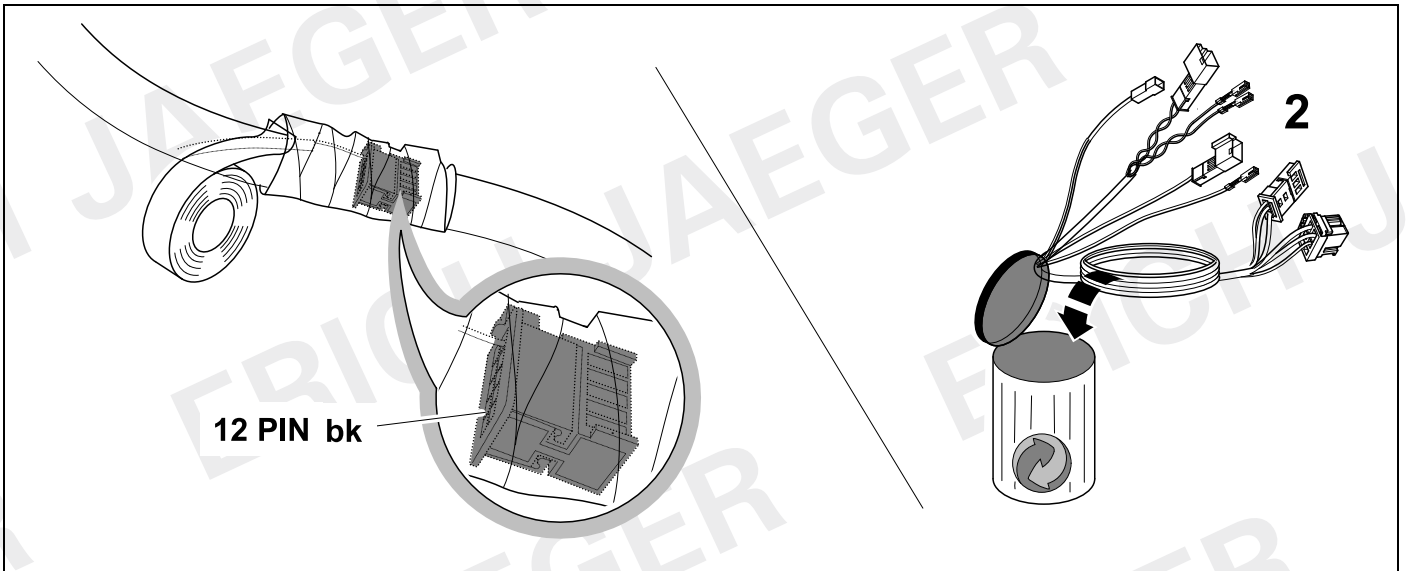

18



11

OPTION 1

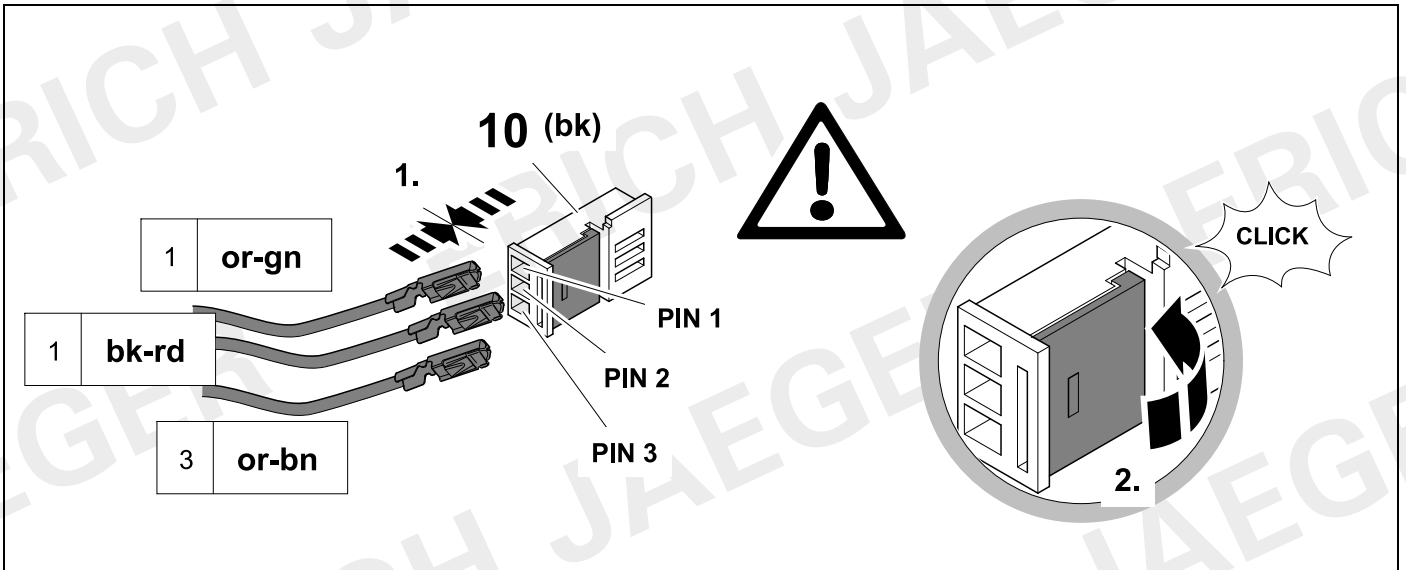

19



11

OPTION 1

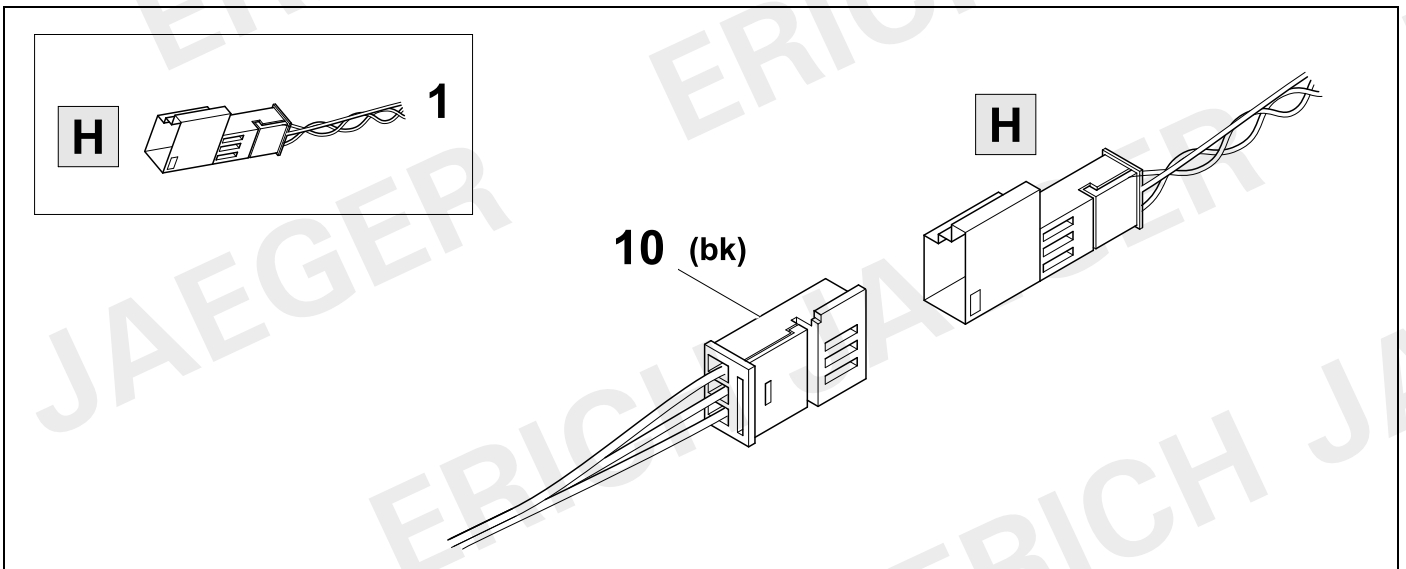

20

OPTION 1

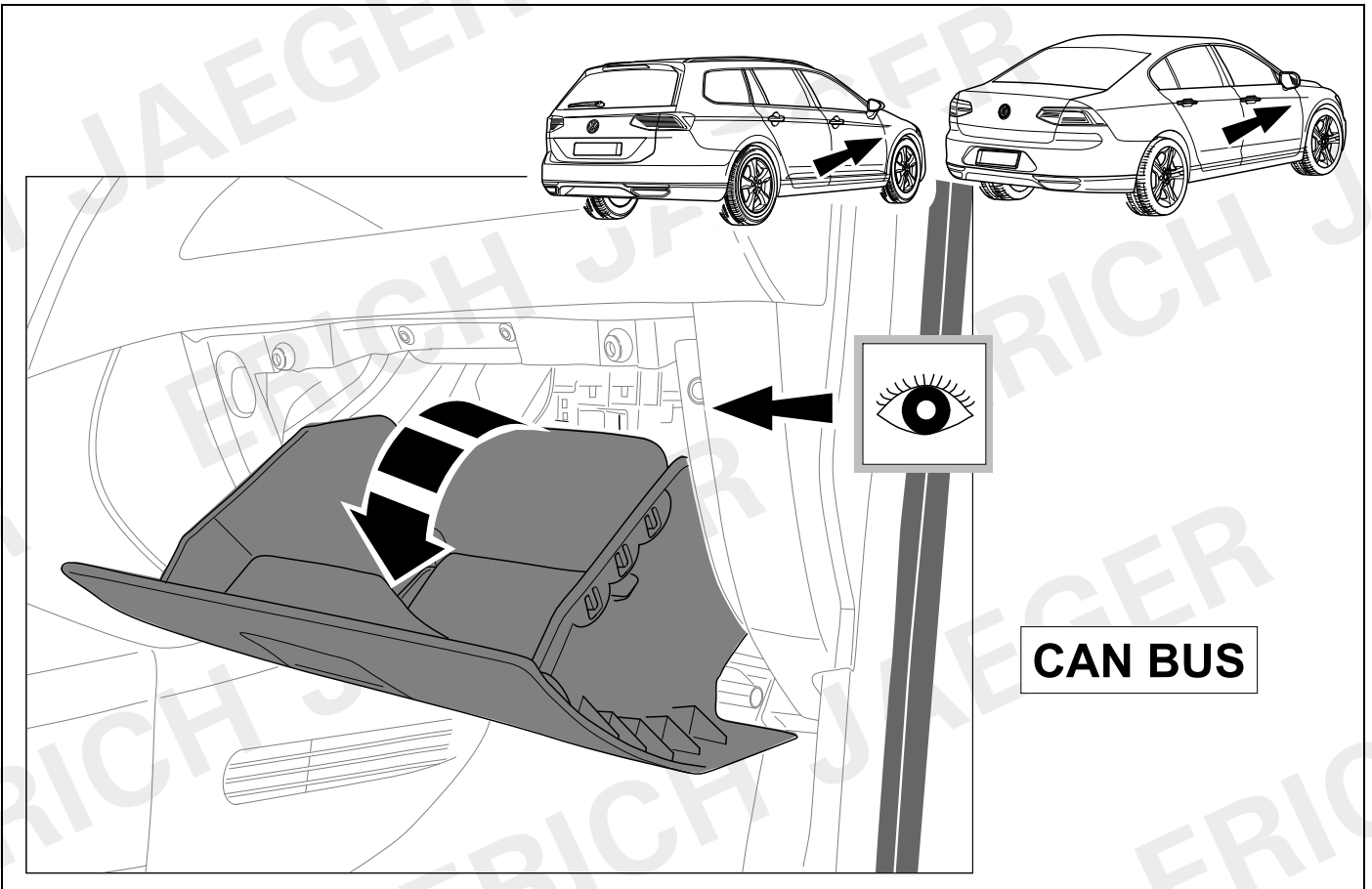

21

👁️ ➔ 11

OPTION 1

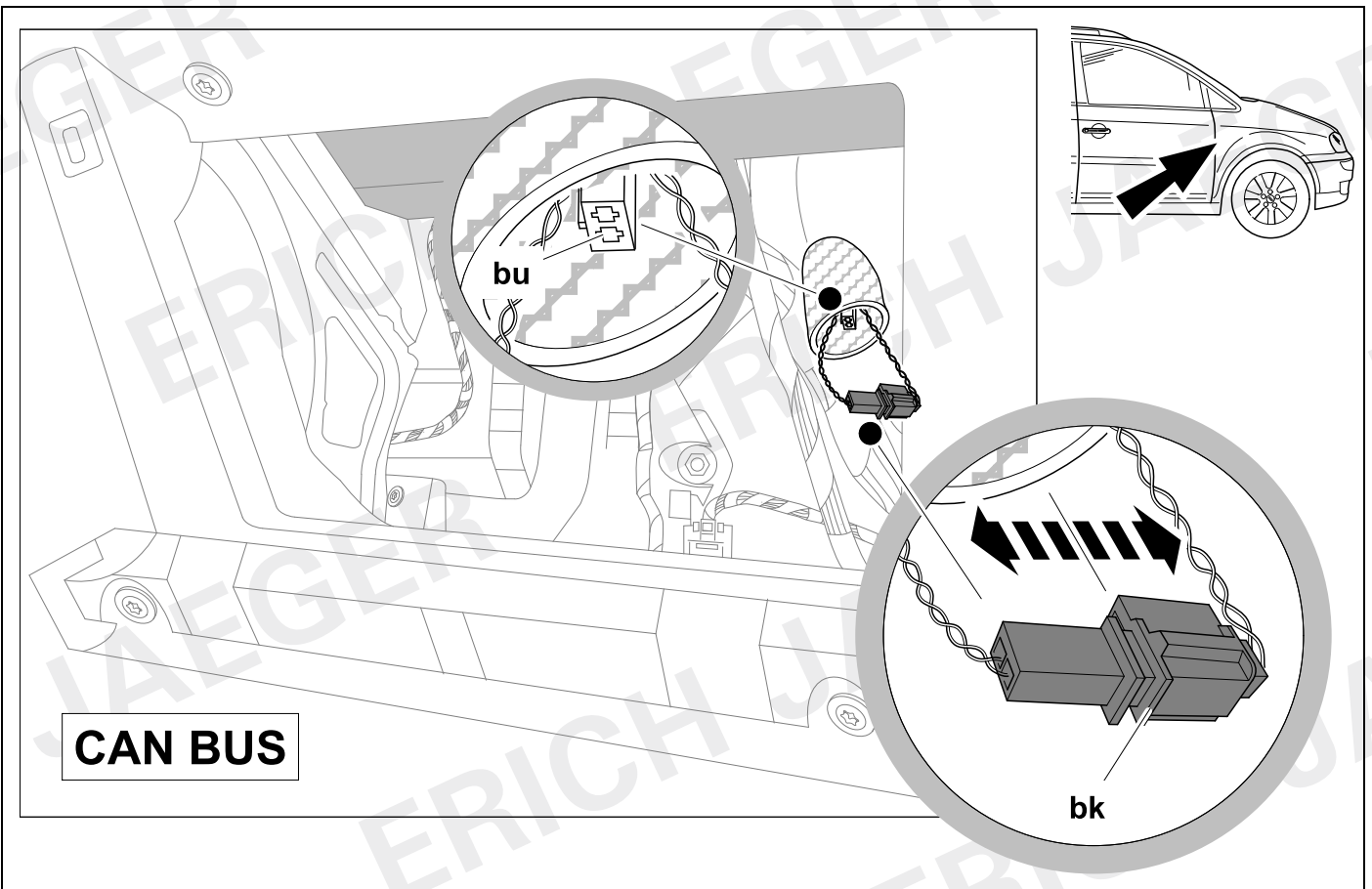

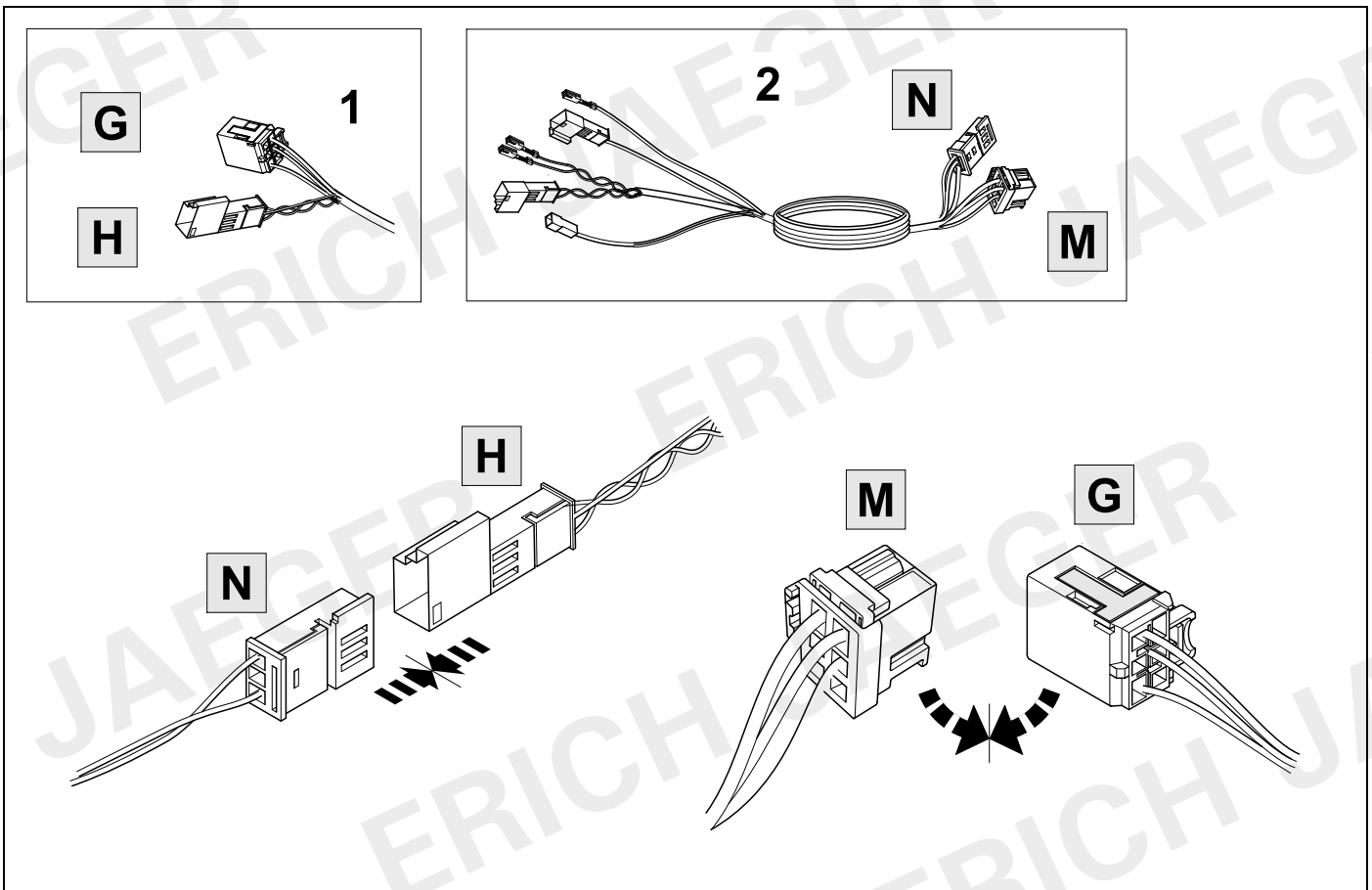
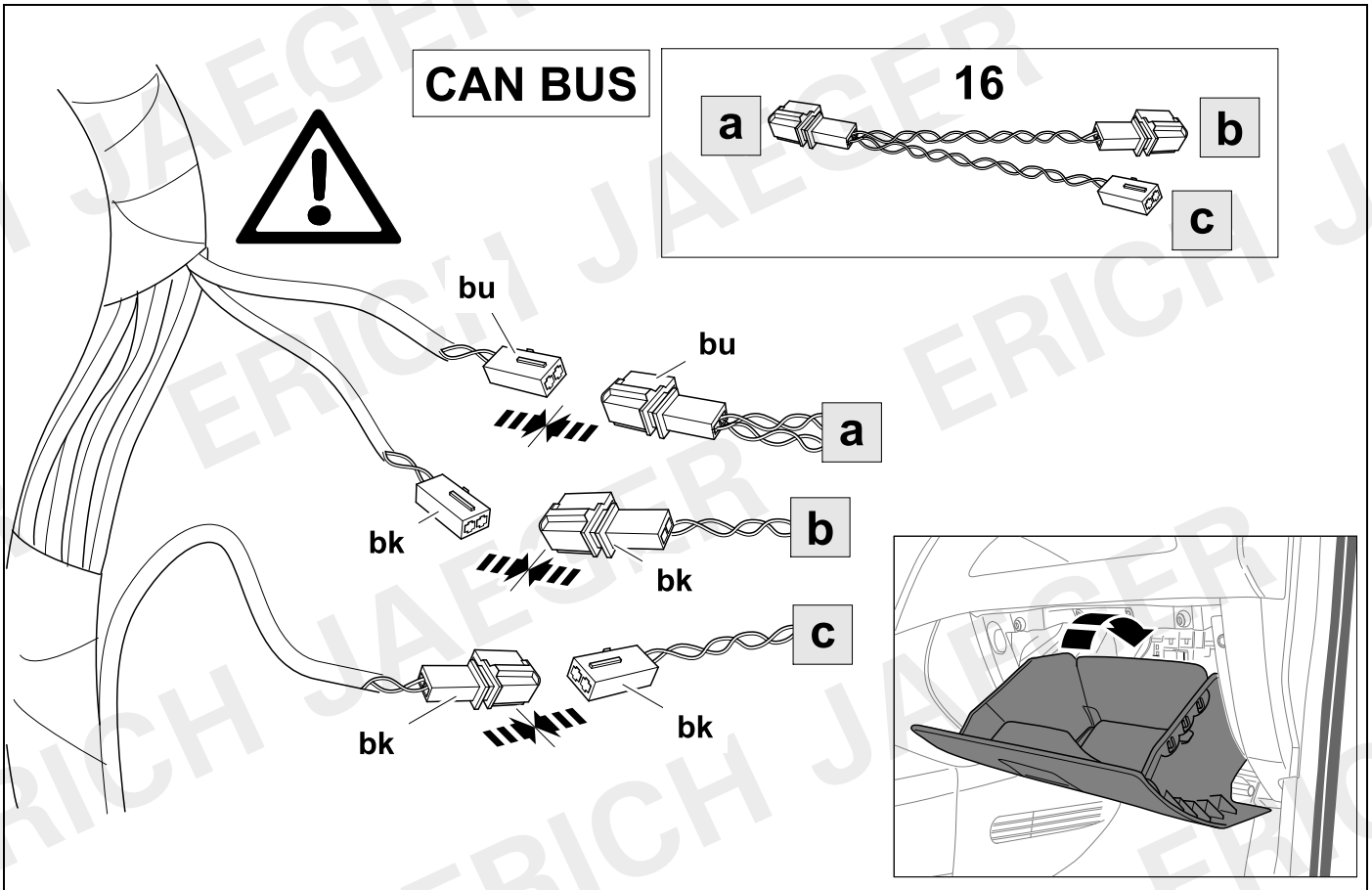

24

OPTION 2

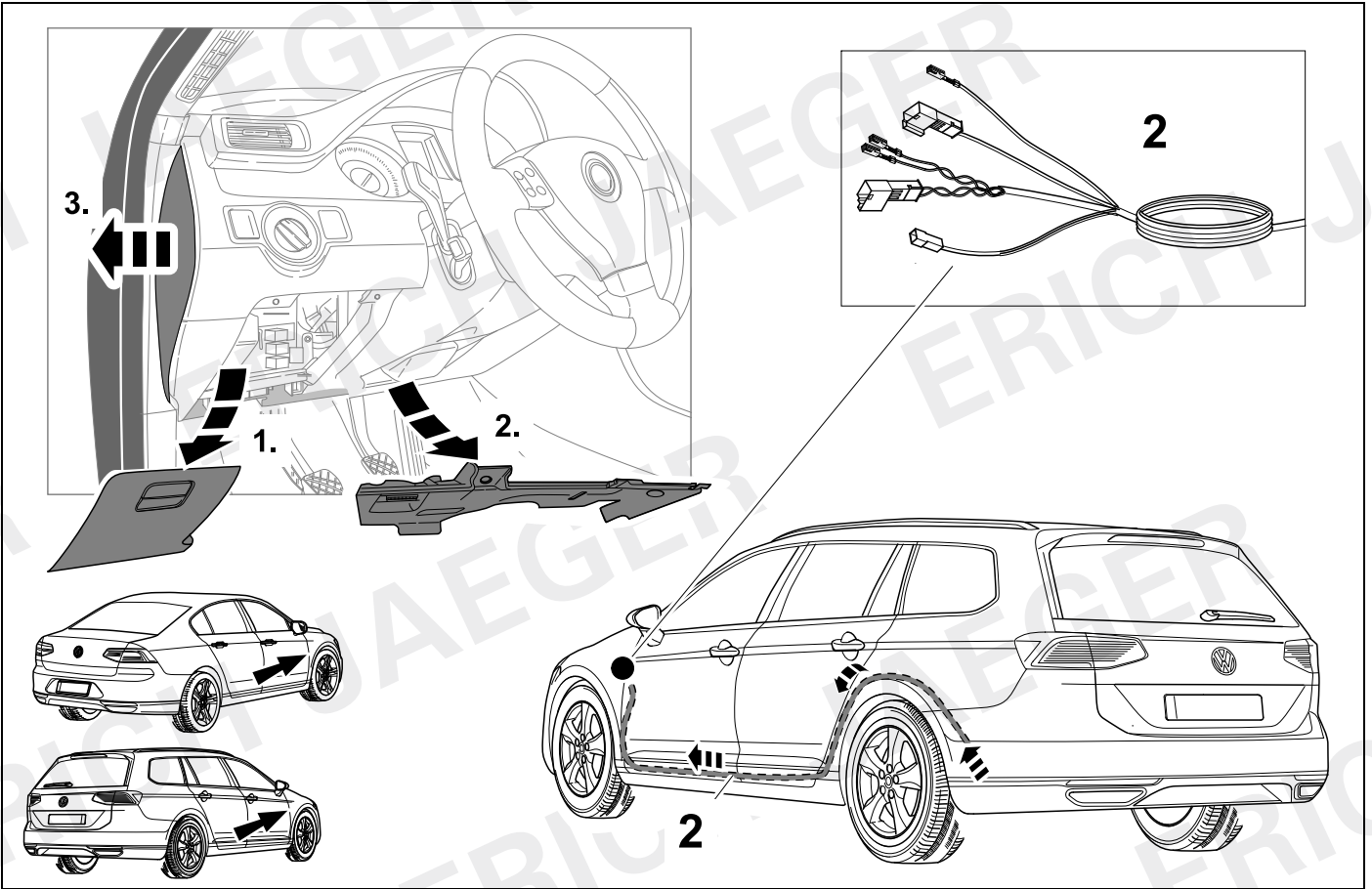

25



11

OPTION 2

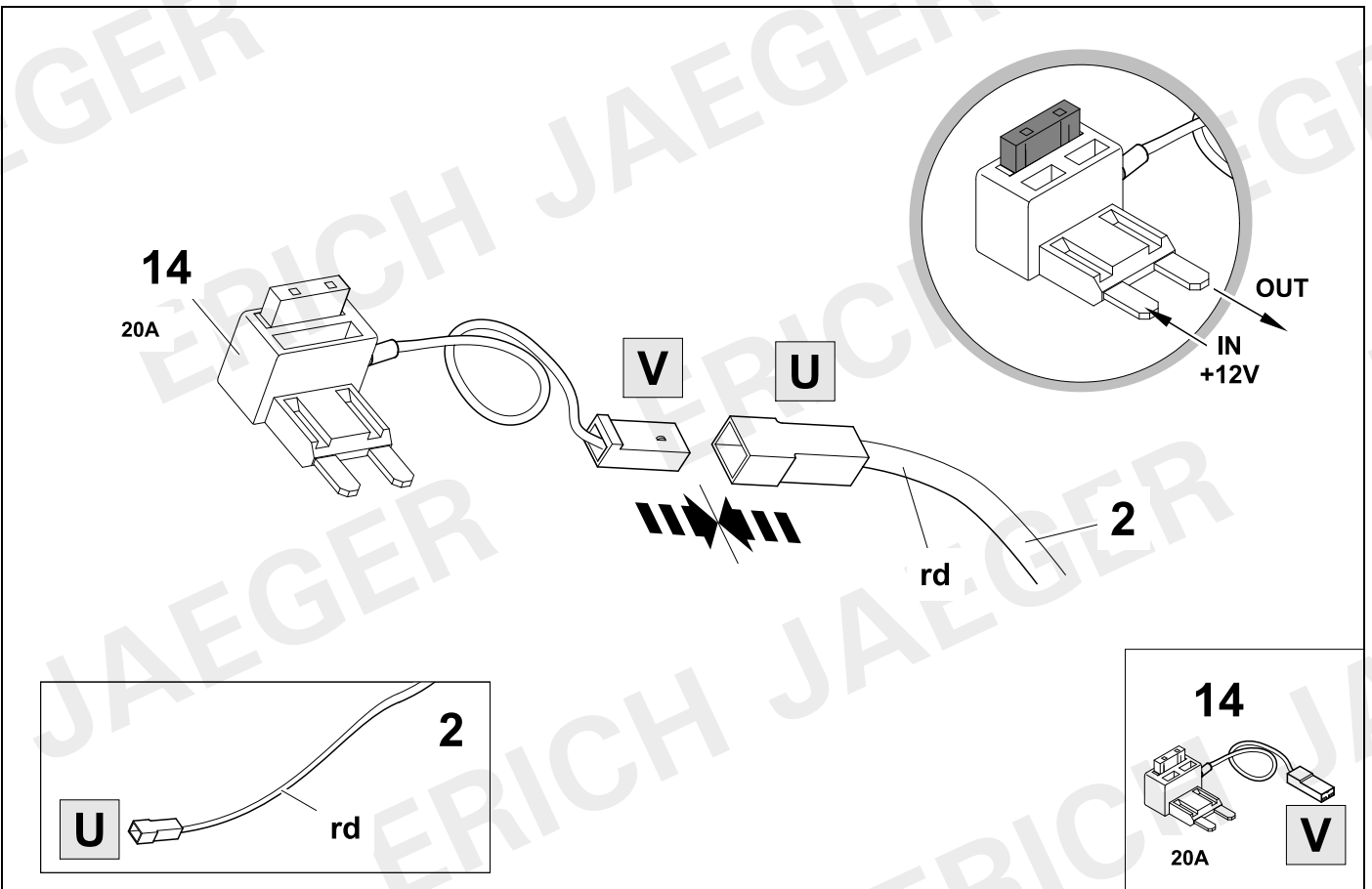

26



44

OPTION 2

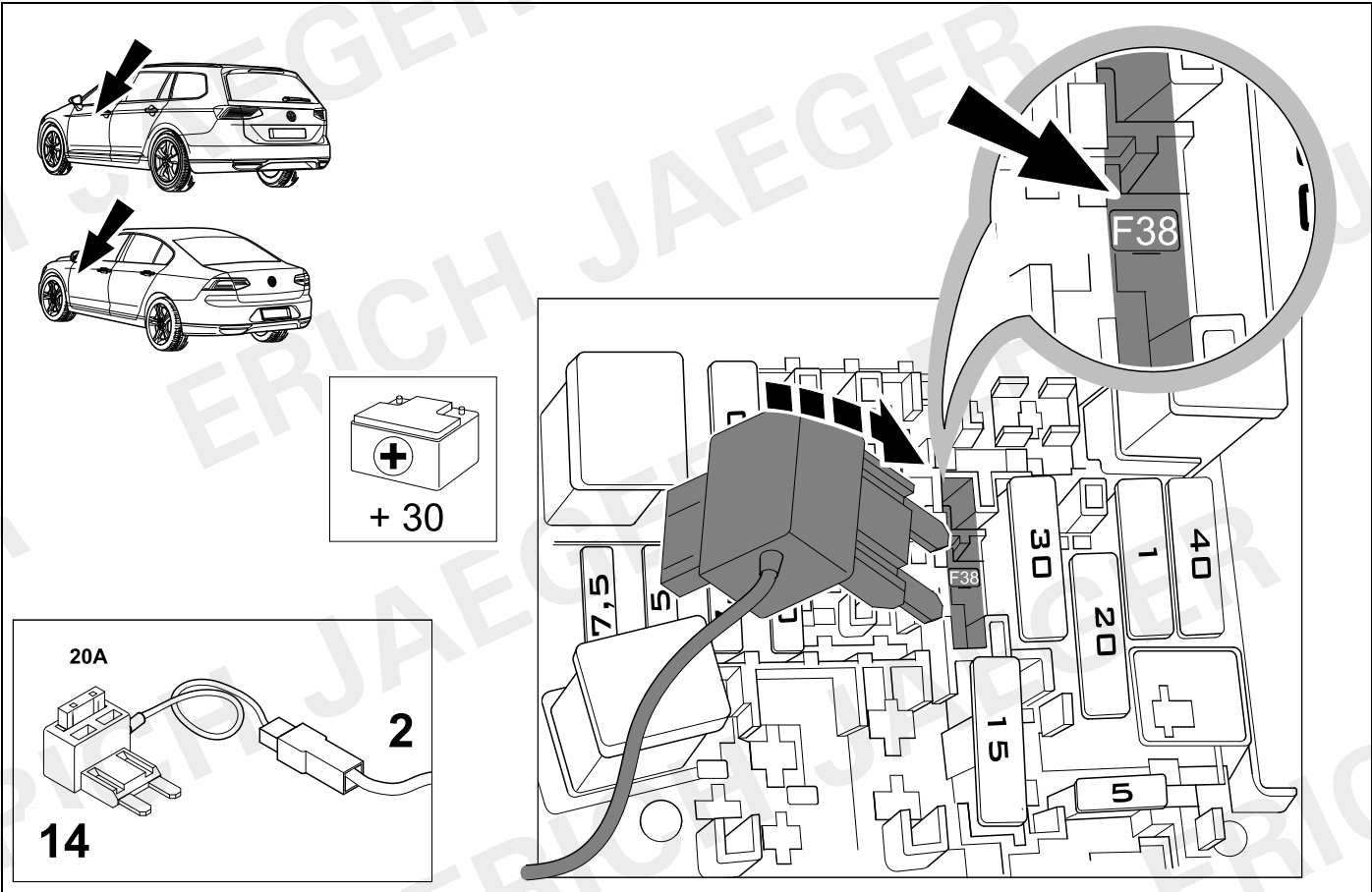

27

OPTION 2

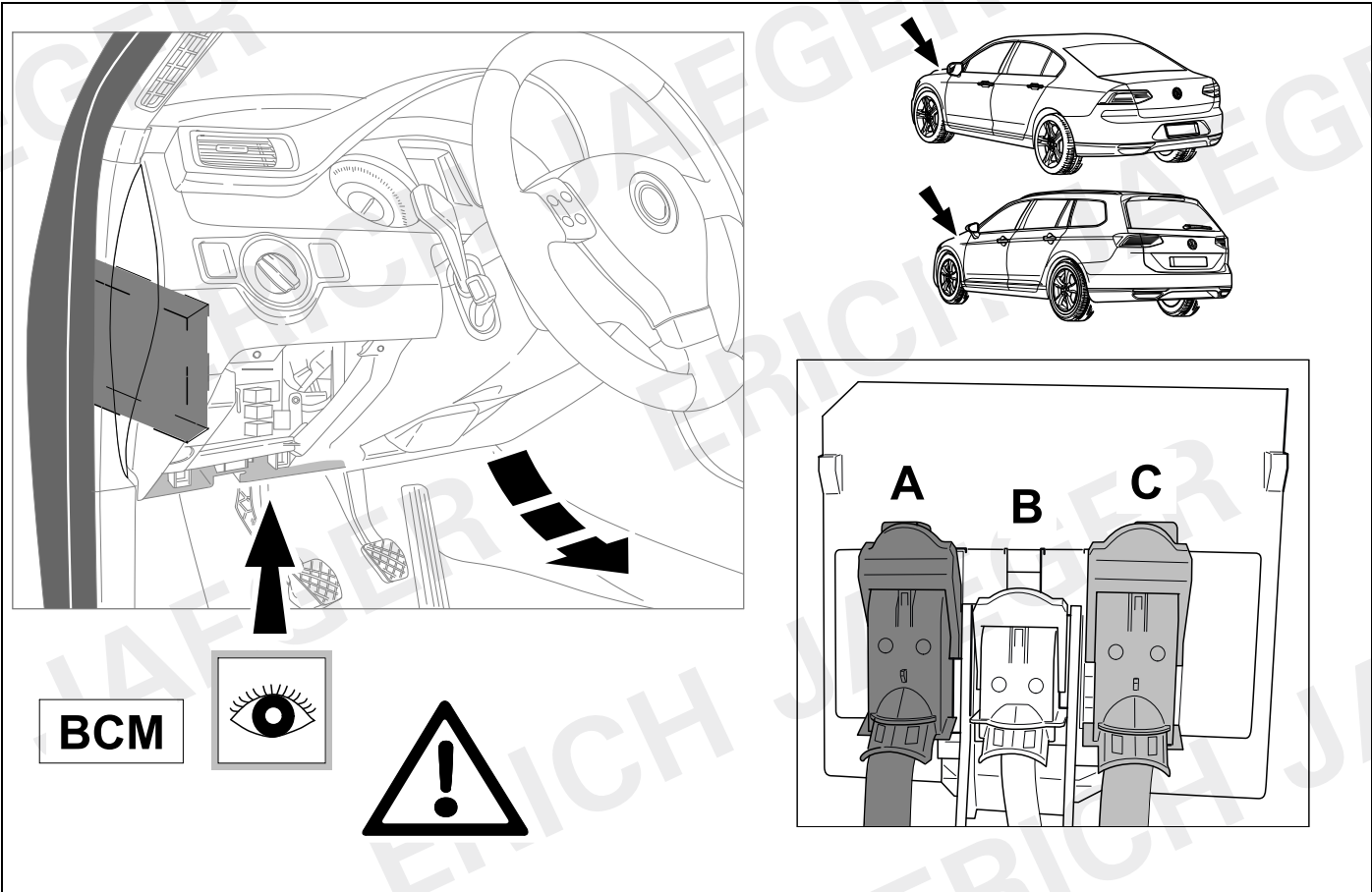

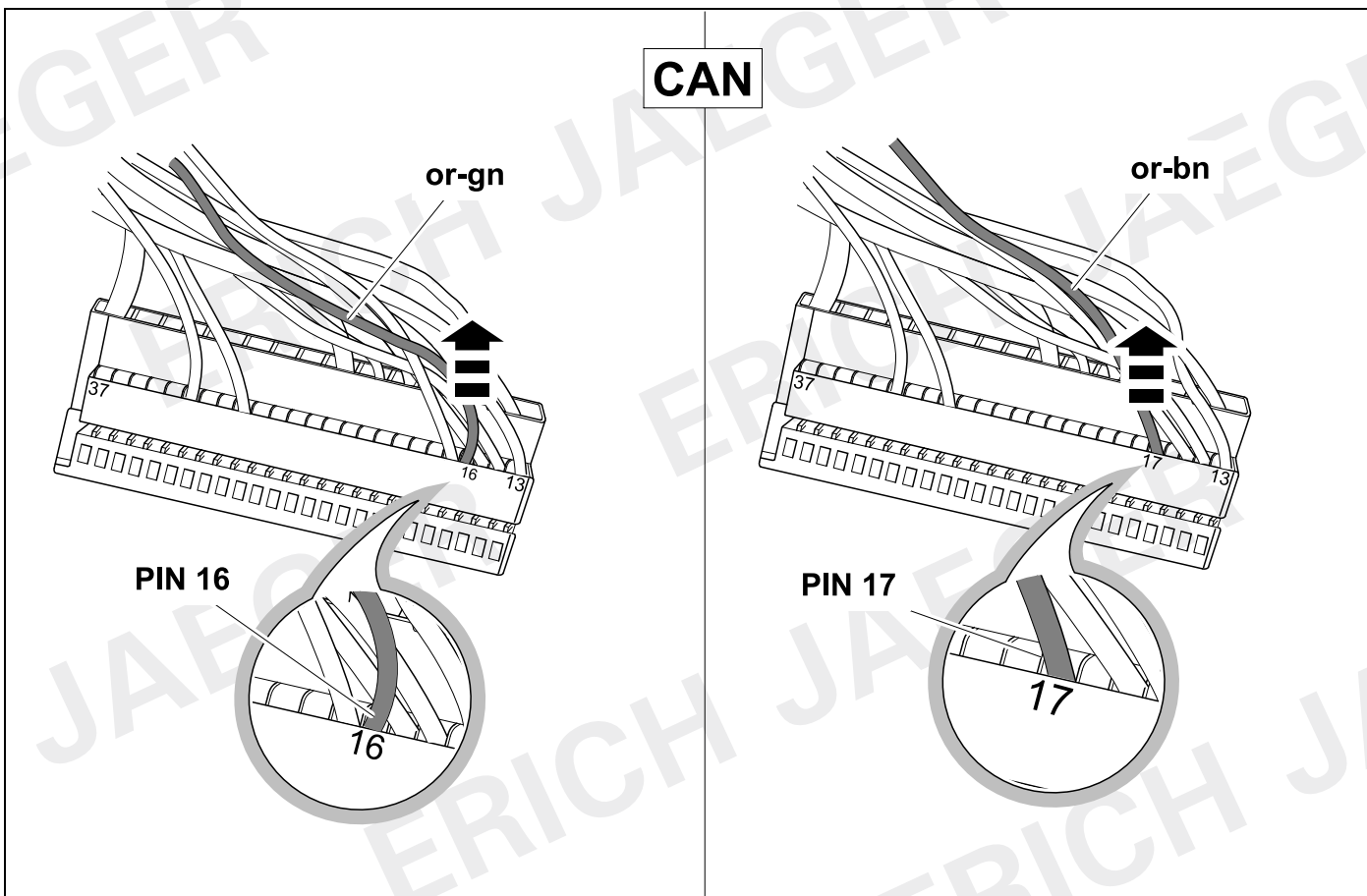
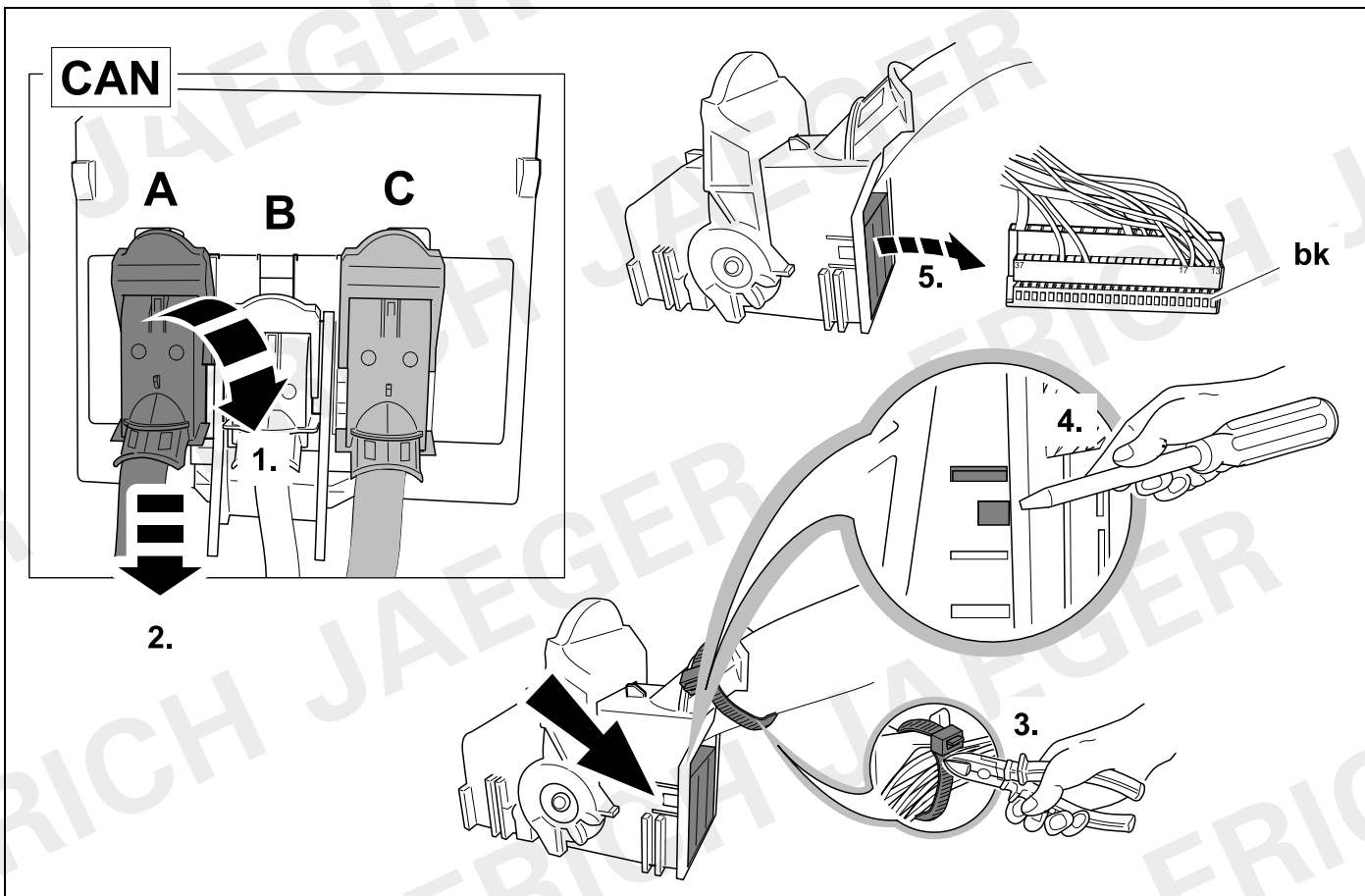

30



11

OPTION 2

CAN

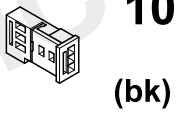
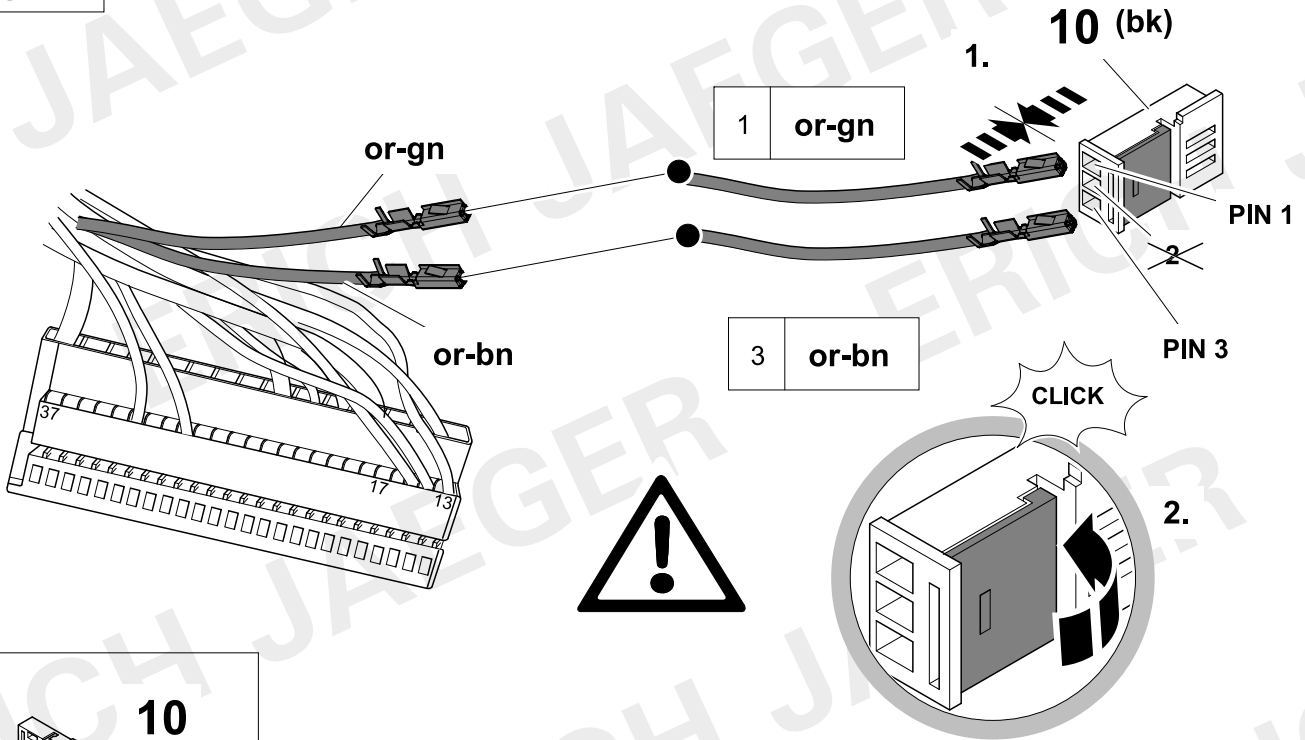

31



11

OPTION 2

CAN

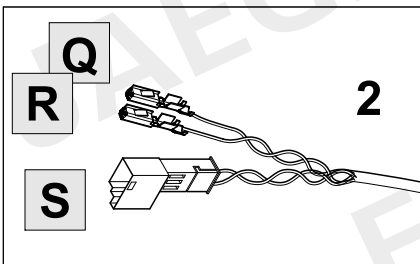
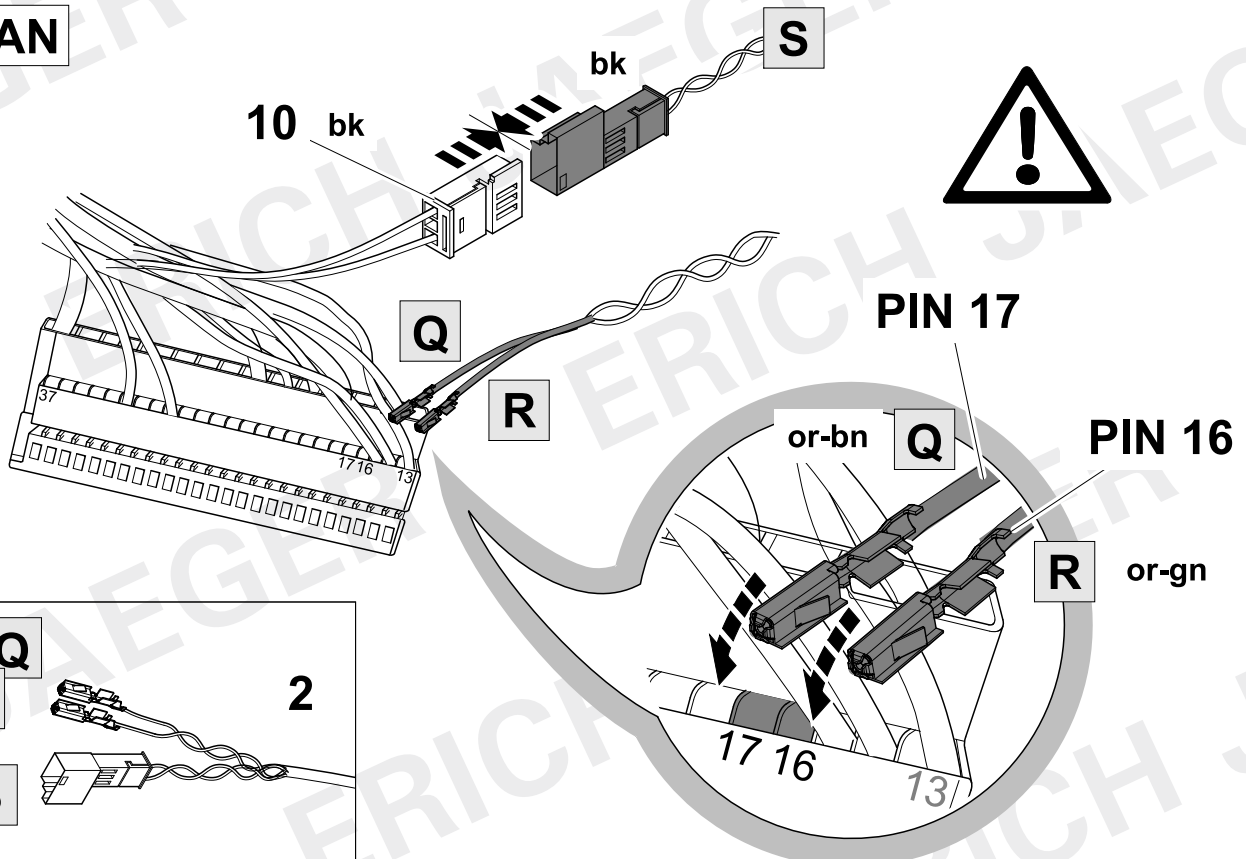

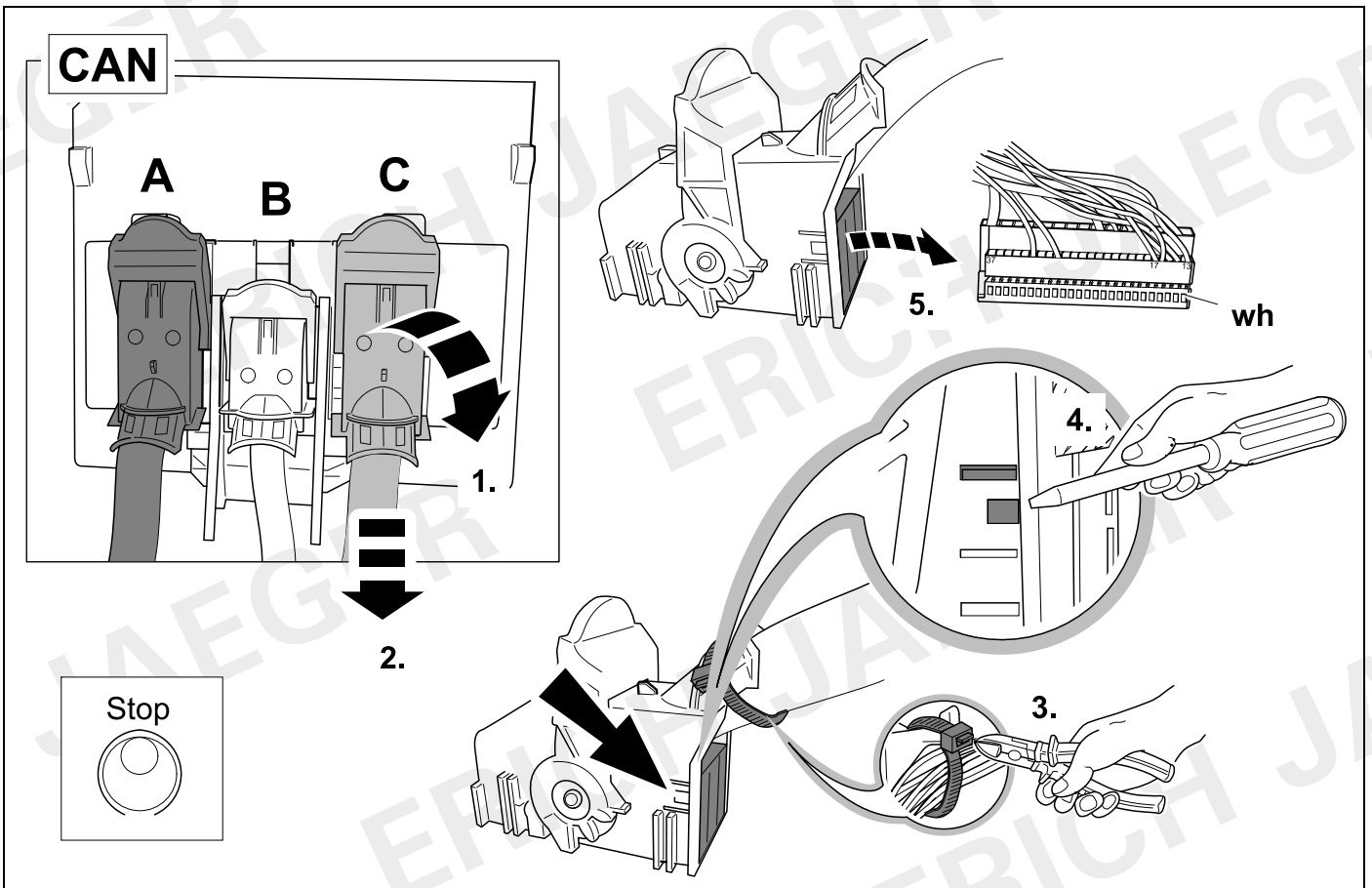
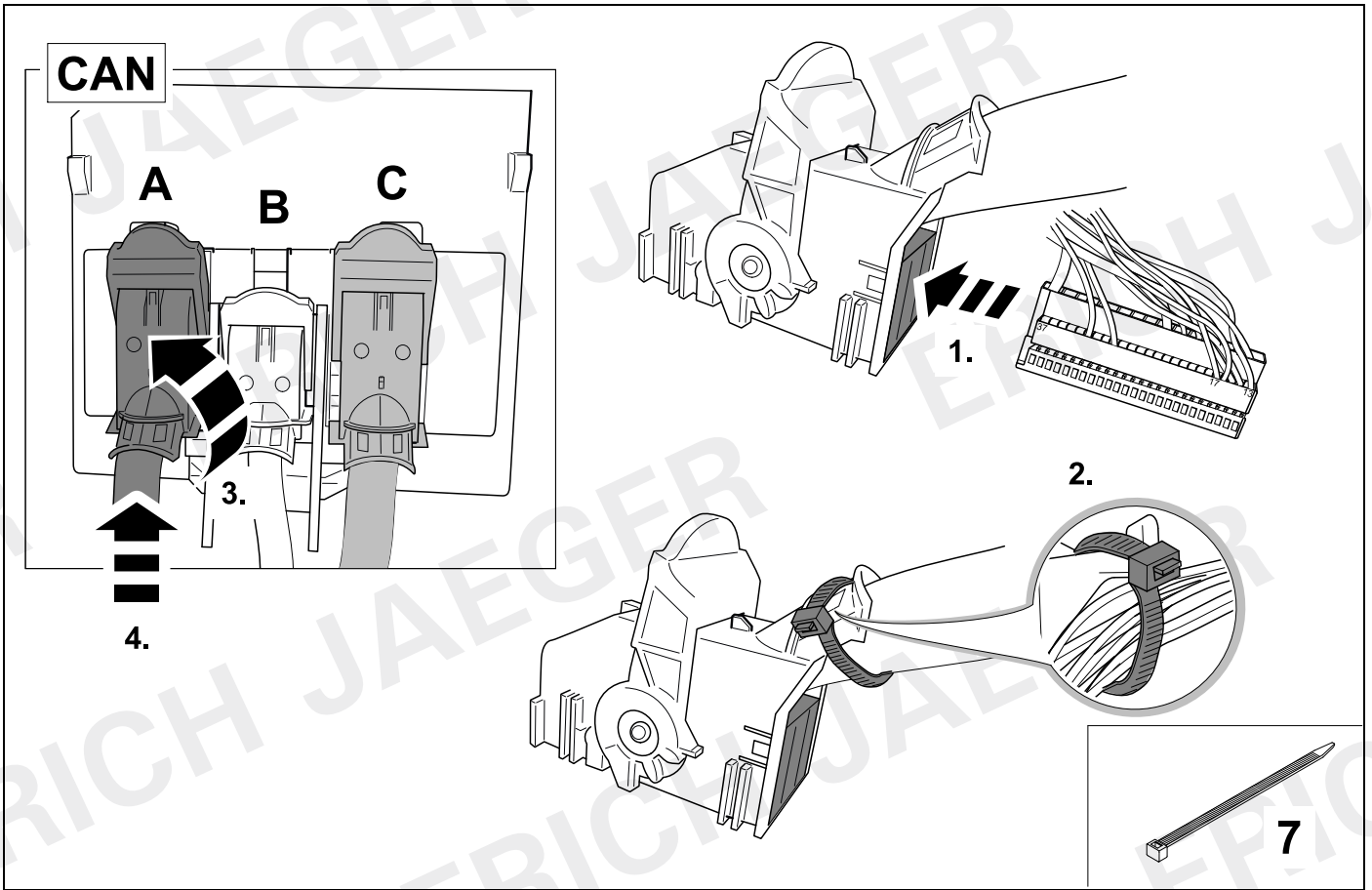

34



11

OPTION 2

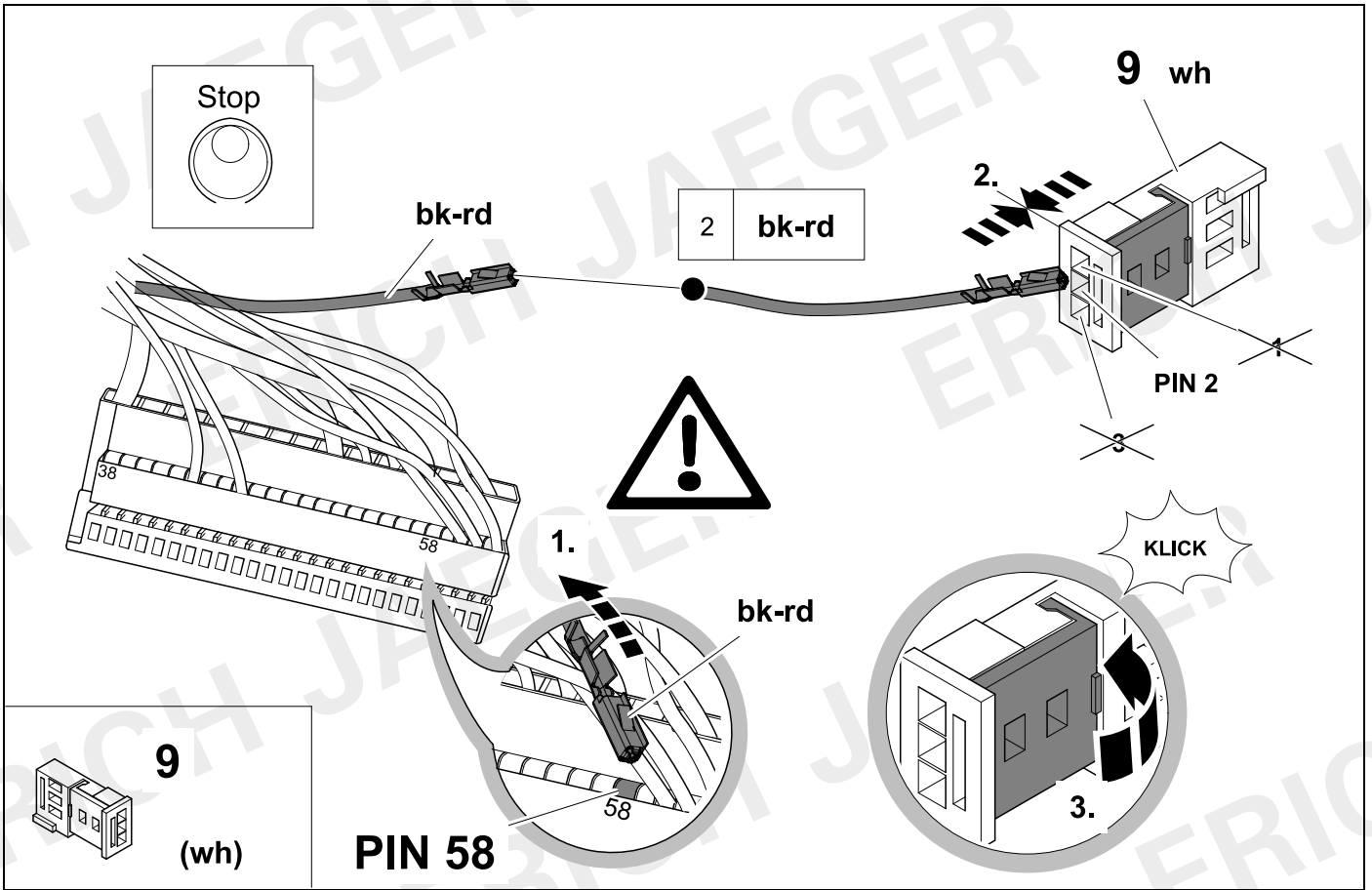

35



11

OPTION 2

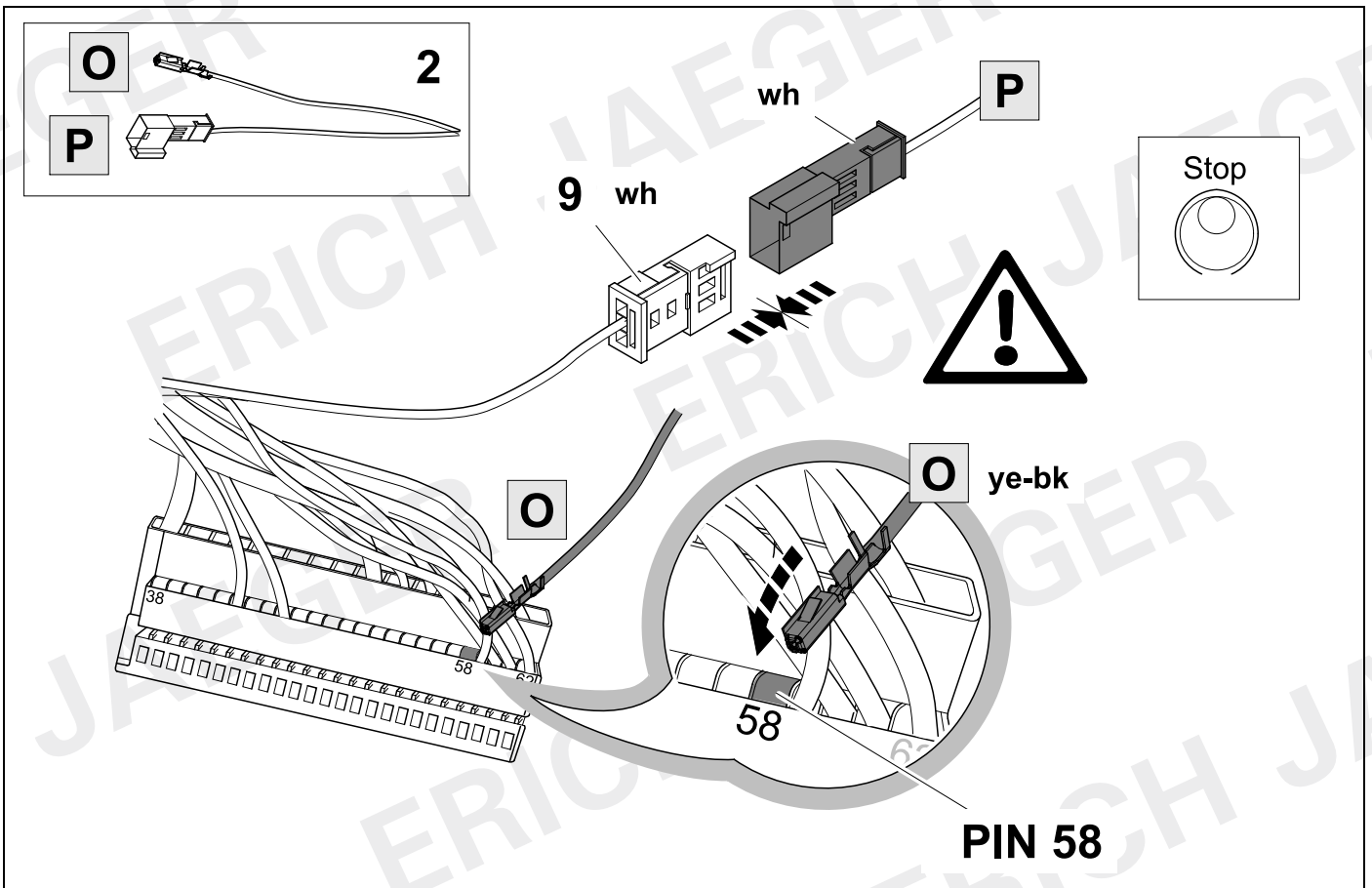

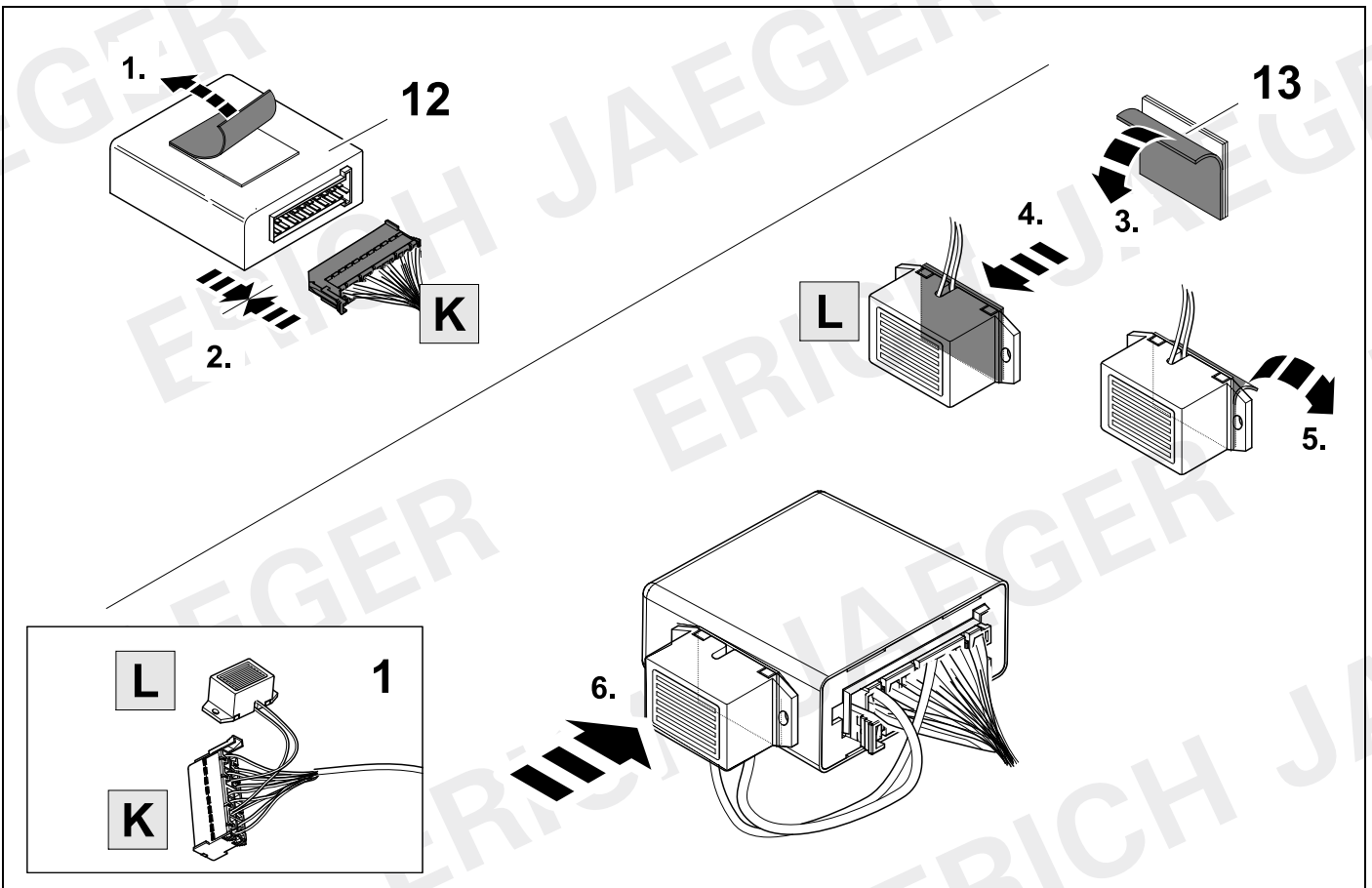
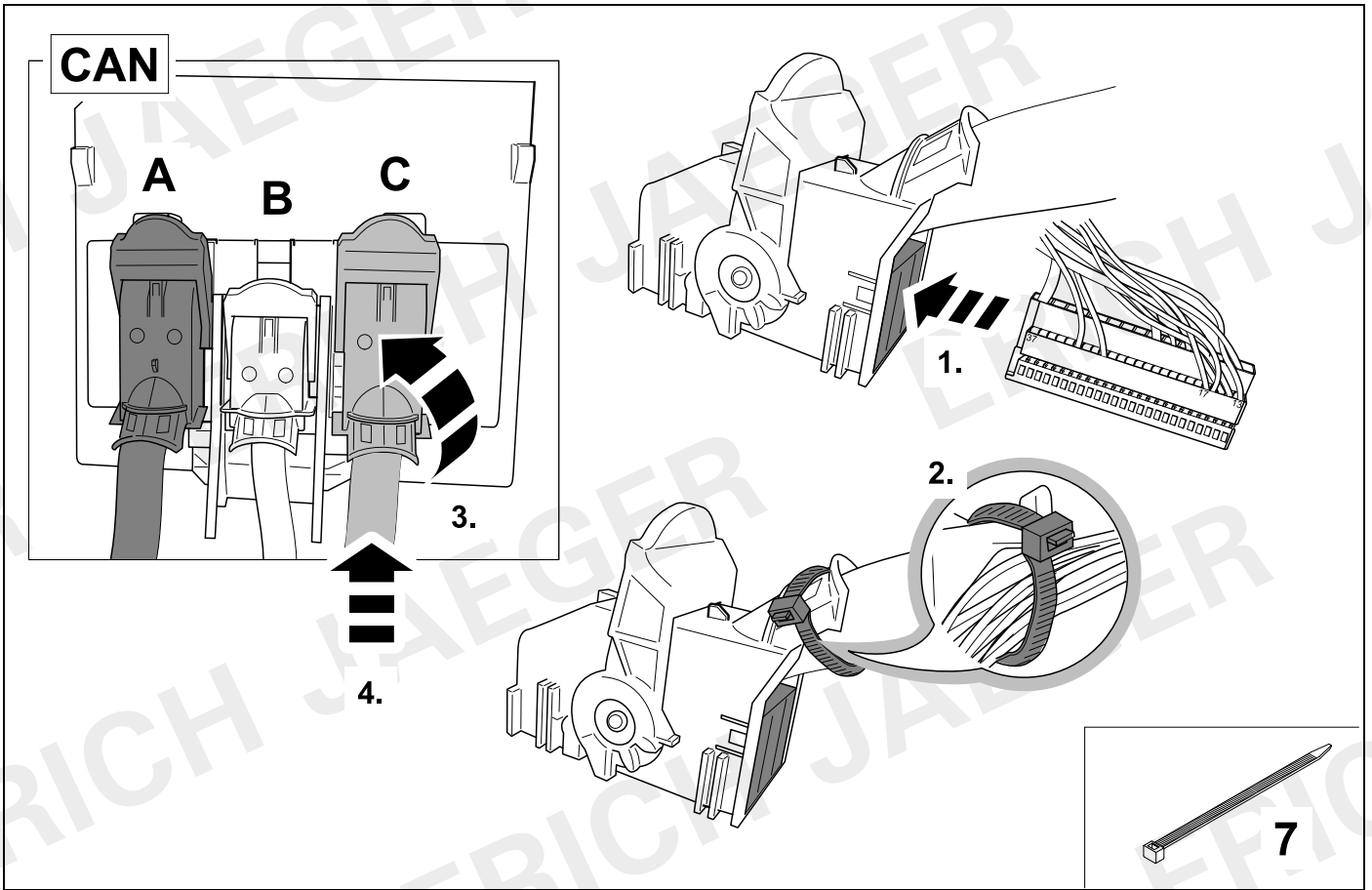

38

VARIANT

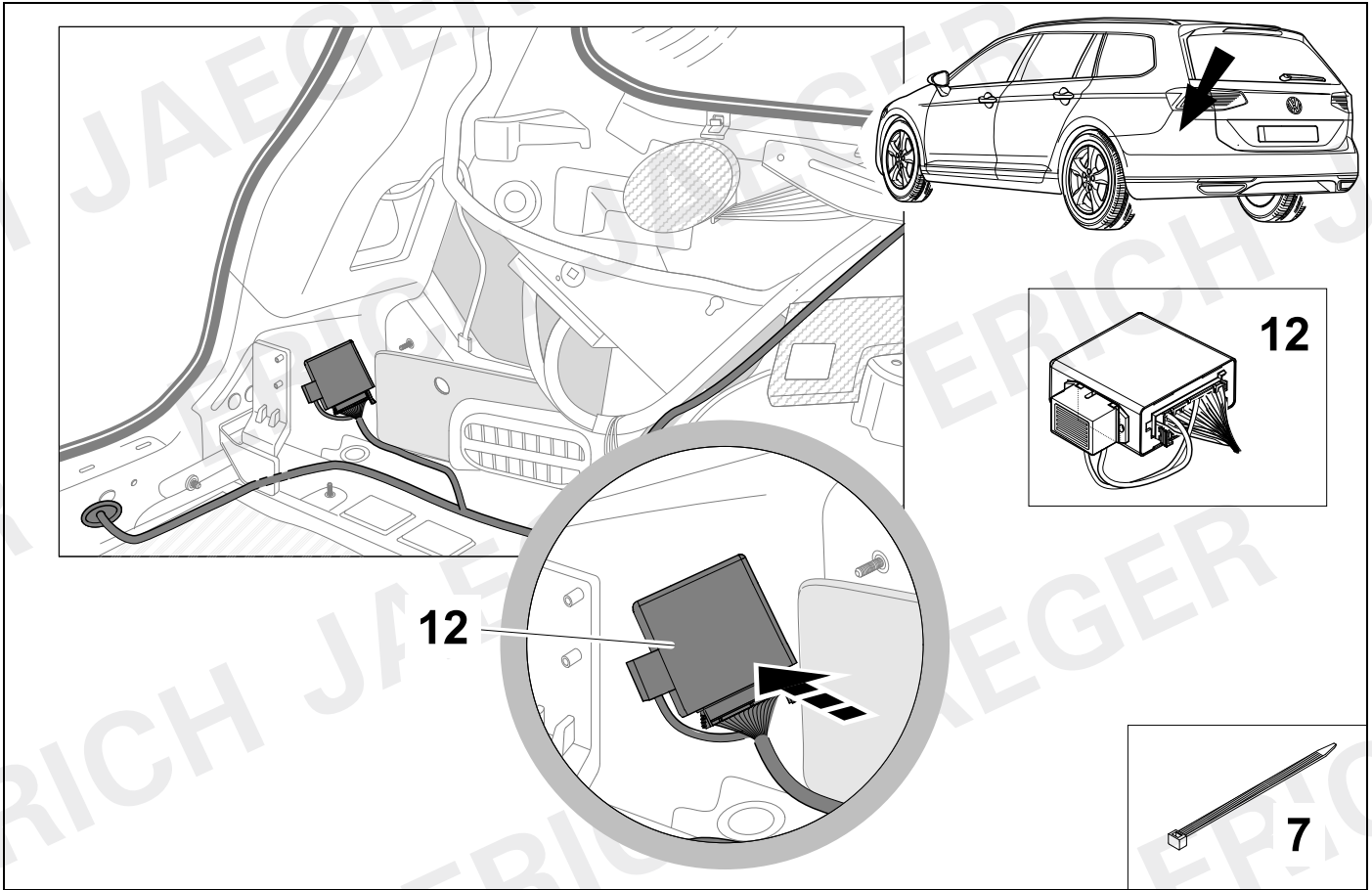

39

LIMOUSINE

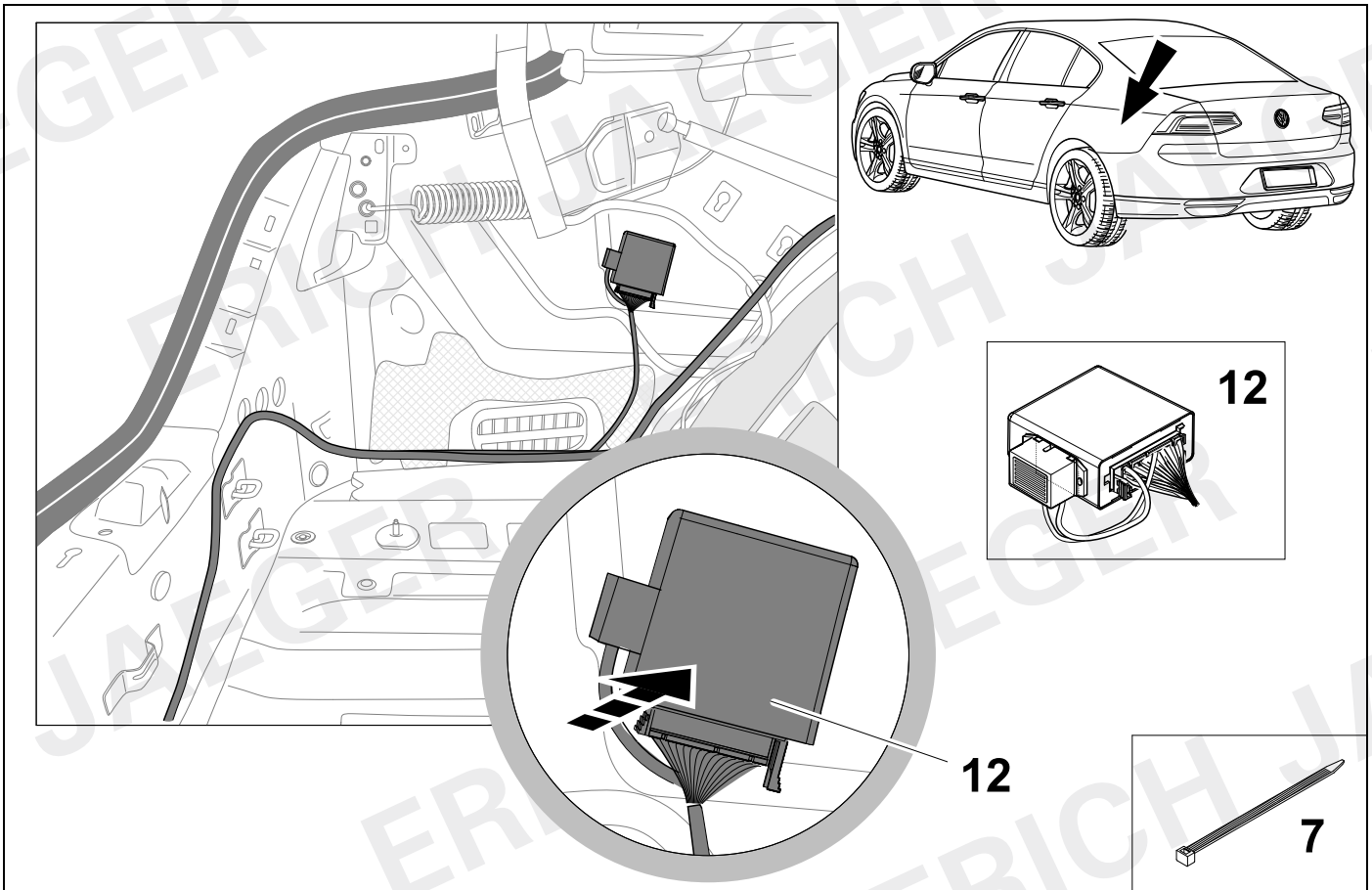

40

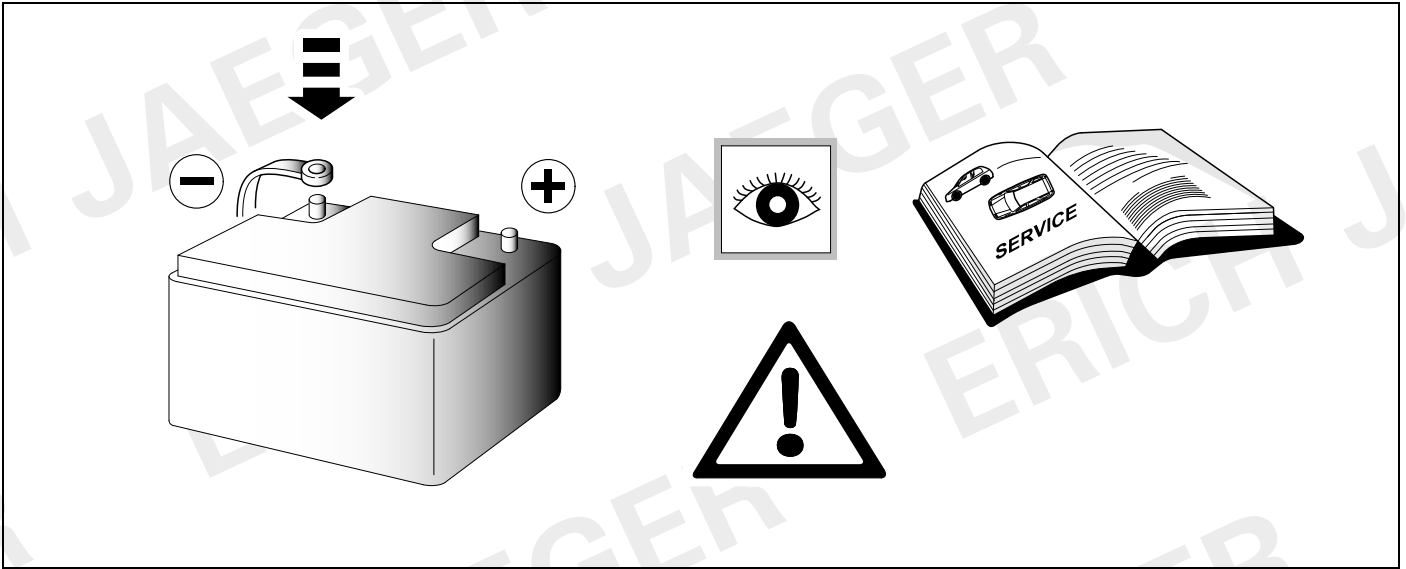

41

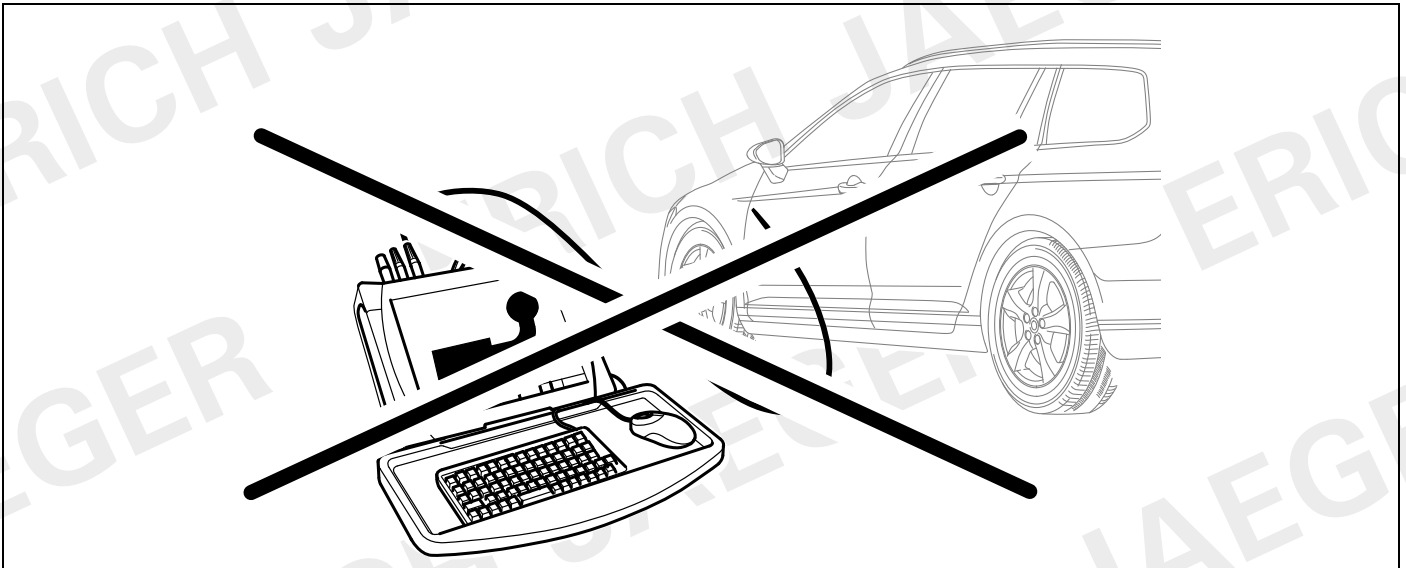

42 CHECK

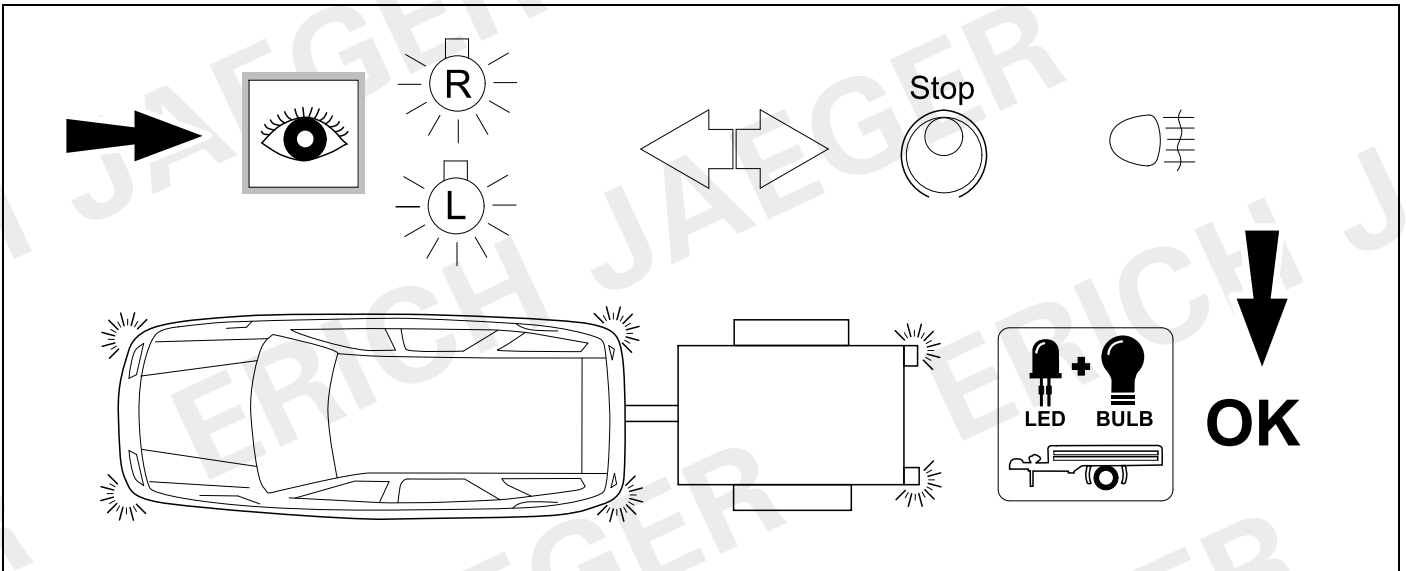

43 CHECK

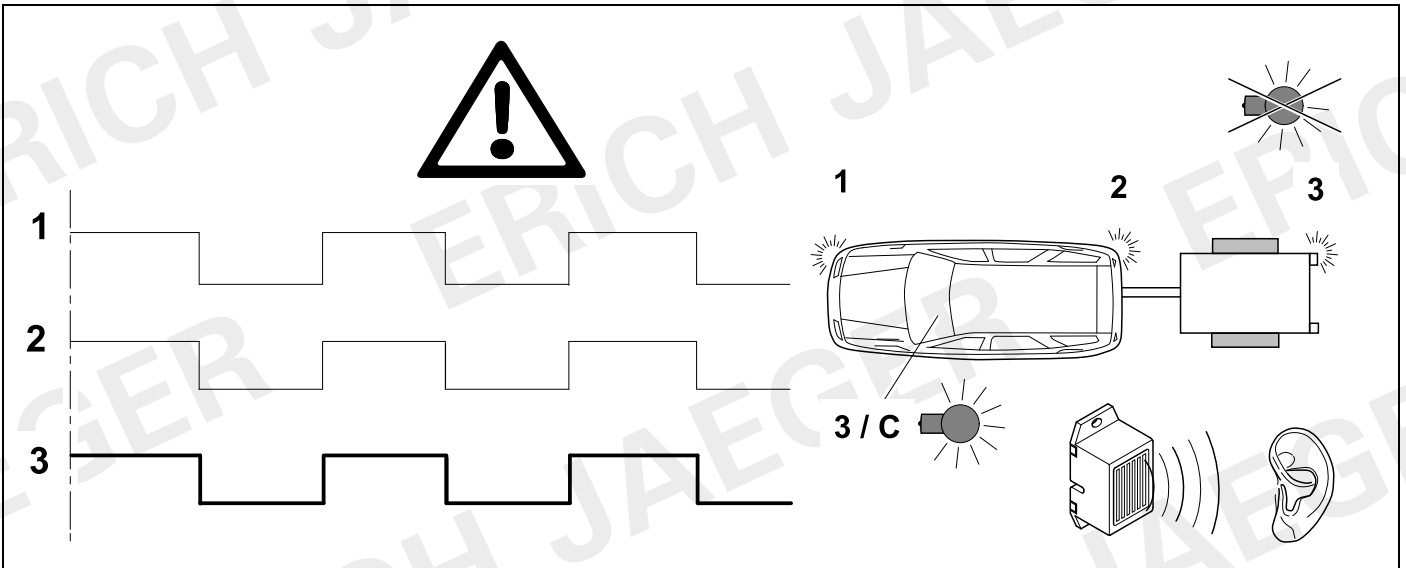

44 INFORMATION



26

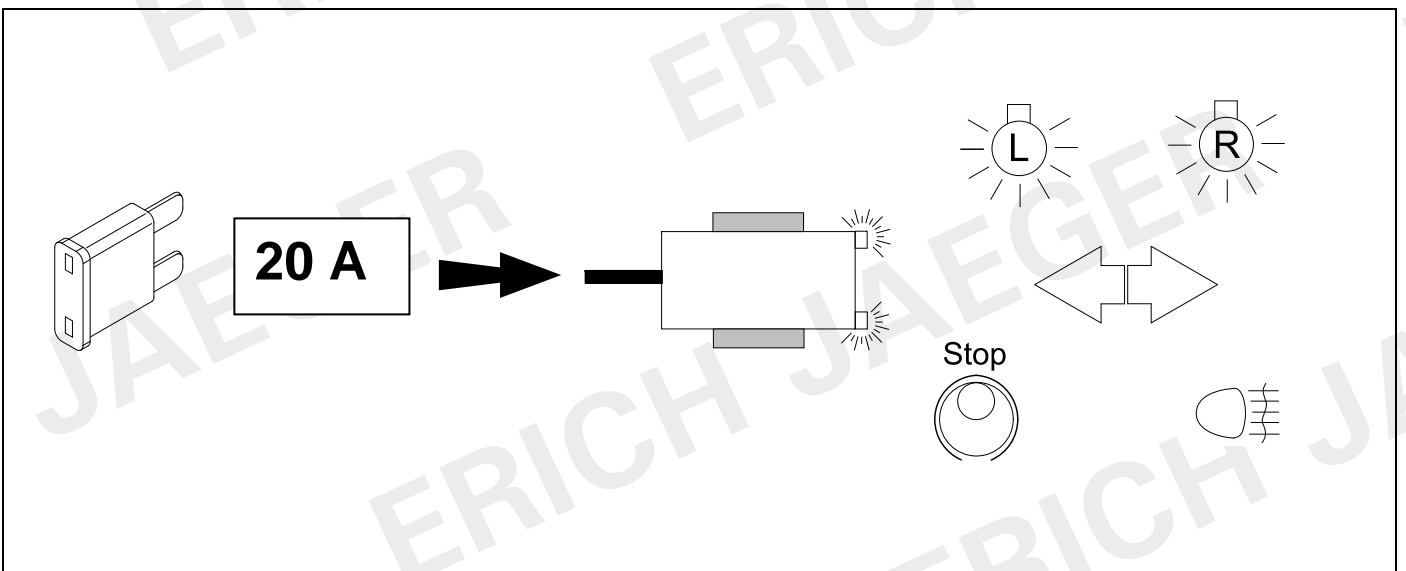

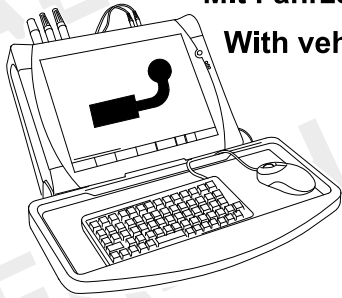

Mit Fahrzeugkodierung
With vehicle coding

46



50

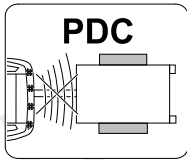

PDC

TSP
Trailer
Stability
Program



Trailer
Assistant



! Achtung !

Diese Kodierung kann eventuell nach einem Besuch bei einer autorisierten Werkstatt verloren gehen!

! Attention !

These codings may be lost after visiting an authorized workshop!

46

OPTION vehicle coding

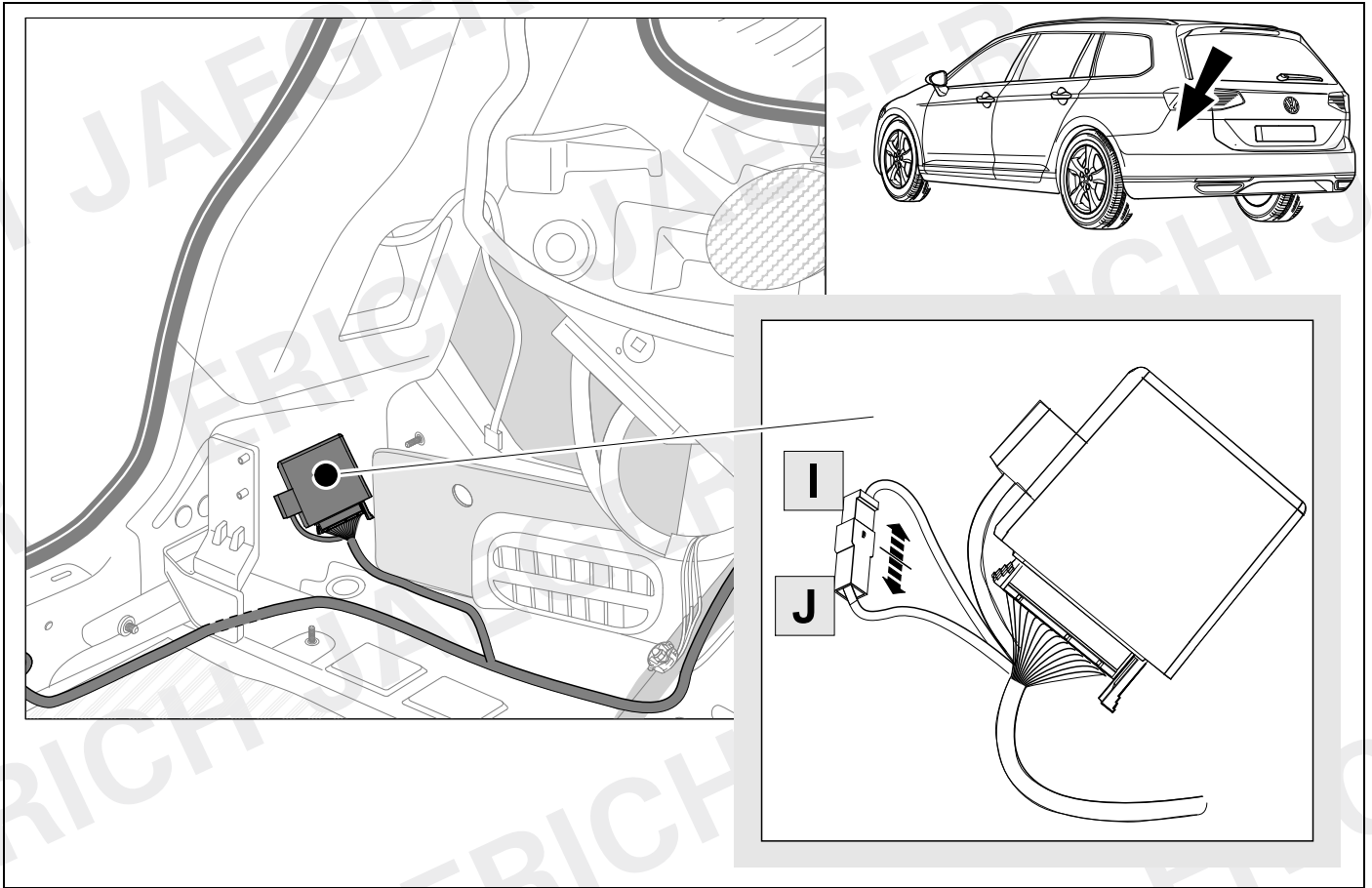

47

OPTION vehicle coding

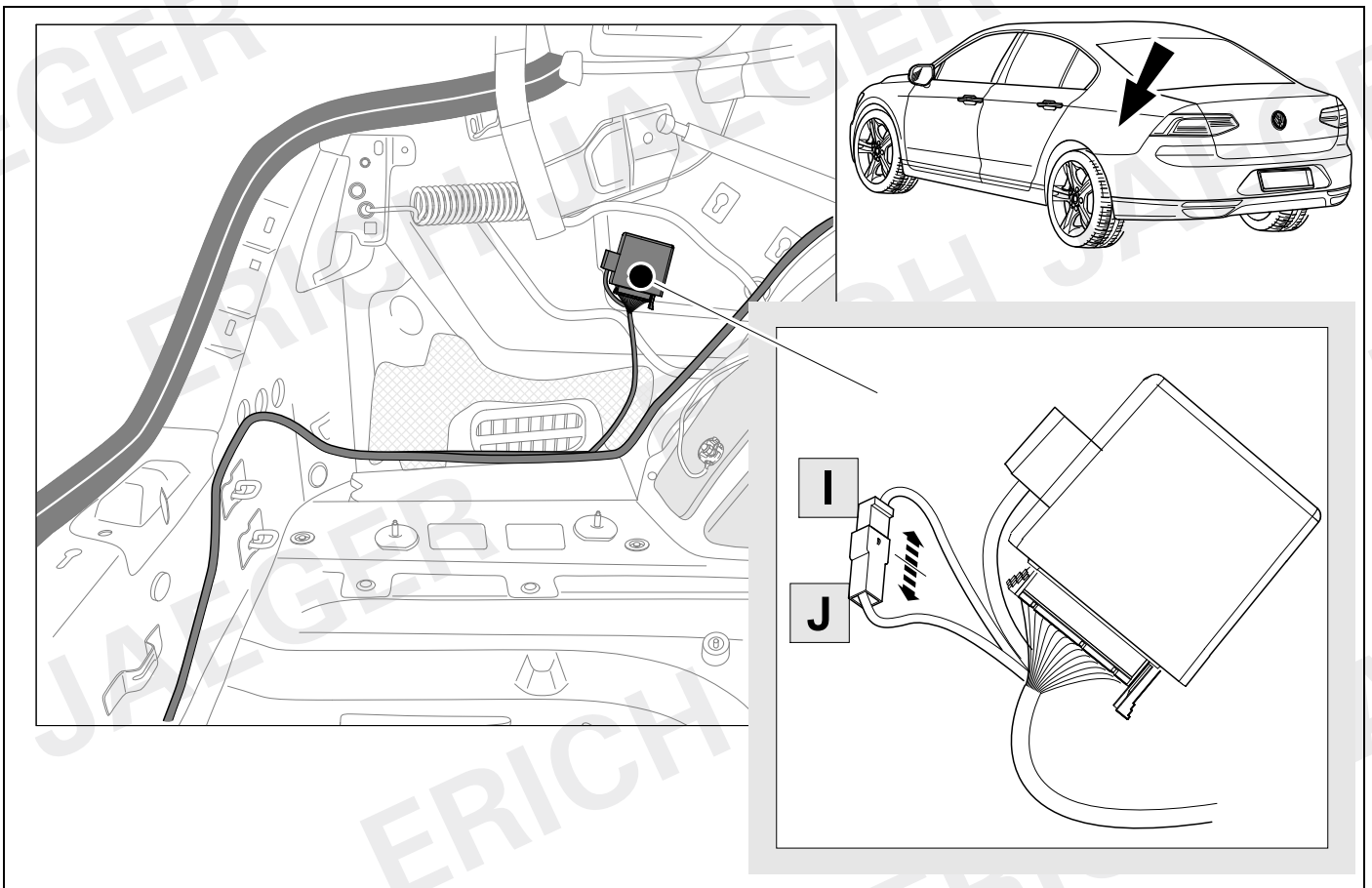

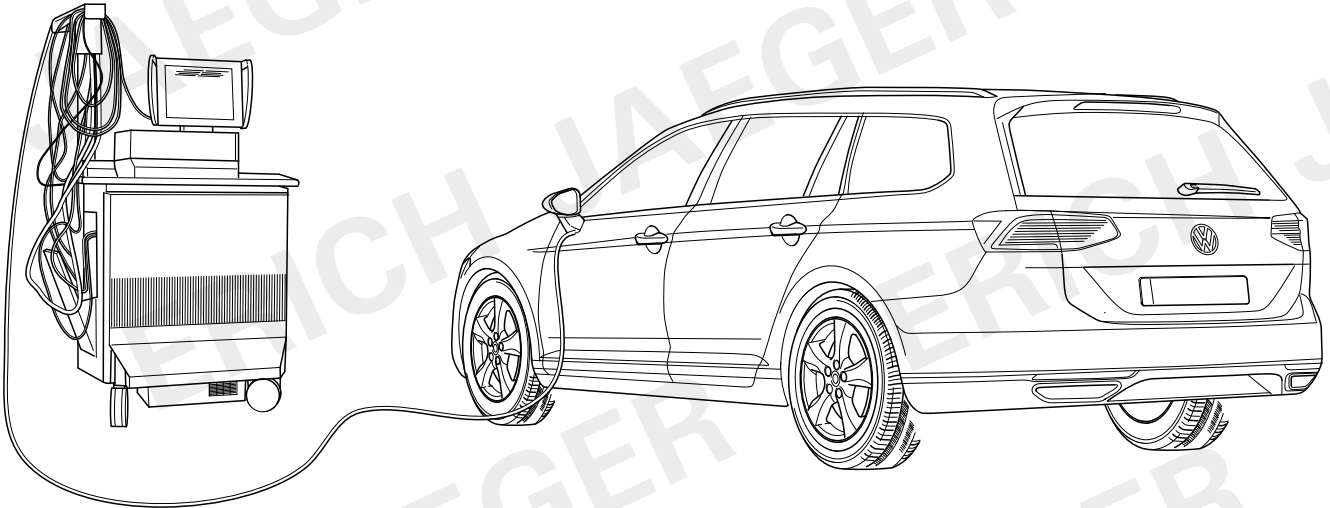

D	GB	F
<p>Codierung bitte wie folgt durchführen:</p> <ul style="list-style-type: none"> ➤ Alternative Diagnosedienstleister bzw. Diagnosemethoden (lokal / offline) : <ul style="list-style-type: none"> • ODIS / VCDS • Hella Gutmann (Seite 28) • Autologic • Bosch / KTS • SP Diagnostic • SUN • Westfalia Auto Code • etc. pp. 	<p>Please effect coding as follows:</p> <ul style="list-style-type: none"> ➤ Alternative Diagnosis Services or diagnostic methods (local / offline) : <ul style="list-style-type: none"> • ODIS / VCDS • Hella Gutmann (page 28) • Autologic • Bosch / KTS • SP Diagnostic • SUN • Westfalia Auto Code • etc. pp. 	<p>Veillez suivre le codage suivant:</p> <ul style="list-style-type: none"> ➤ Diagnostic services alternatives ou les méthodes de diagnostic (local/hors ligne) : <ul style="list-style-type: none"> • ODIS / VCDS • Hella Gutmann (page 28) • Autologic • Bosch / KTS • SP Diagnostic • SUN • Westfalia Auto Code • etc. pp.
I	E	NL
<p>Favore codifica effettuate come segue:</p> <ul style="list-style-type: none"> ➤ -Alternativa Diagnosi Servizio o medoti diagnostici (locale/offline) : <ul style="list-style-type: none"> • ODIS / VCDS • Hella Gutmann (pagina 28) • Autologic • Bosch / KTS • SP Diagnostic • SUN • Westfalia Auto Code • etc. pp. 	<p>Por favor de codificación lleva a cabo como sigue:</p> <ul style="list-style-type: none"> ➤ Servicio de Diagnóstico alternativa o métodos de diagnóstico (locales/ fuera de linea) : <ul style="list-style-type: none"> • ODIS / VCDS • Hella Gutmann (pagina 28) • Autologic • Bosch / KTS • SP Diagnostic • SUN • Westfalia Auto Code • etc. pp. 	<p>Gelieve codering ais volgt ultgevoerd:</p> <ul style="list-style-type: none"> ➤ Alternatief Diagnose Dienst of diagnostische methoden (lokale/offline) : <ul style="list-style-type: none"> • ODIS / VCDS • Hella Gutmann (page 28) • Autologic • Bosch / KTS • SP Diagnostic • SUN • Westfalia Auto Code • etc. pp.

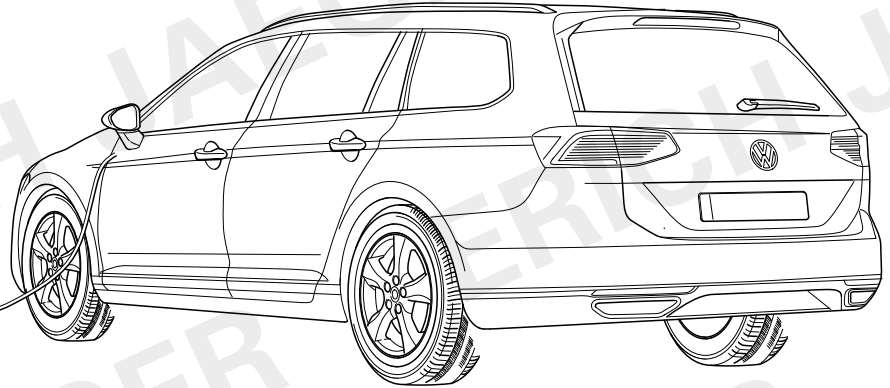
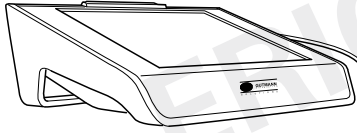

D	GB	F
<p>Die Aktivierung der Anhängerfunktionen muss wie folgt durchgeführt werden:</p> <ol style="list-style-type: none"> 1. Fahrzeugauswahl 2. Zu Diagnose – Codierung wechseln 3. Anhängerkupplung de-/aktivieren 4. Diagnose Interface Bus auswählen 5. Anleitung folgen <p>Fahrzeuge mit Assistenzsystemen</p> <ol style="list-style-type: none"> 6. AHK an Assistenzsysteme anpassen ausführen 7. Anleitung folgen 8. Diagnose 9. Fehlerspeicher auslesen, ggf. löschen 10. Fertig 	<p>The activation of the trailer functions must be performed:</p> <ol style="list-style-type: none"> 1. Vehicle selection 2. switch to diagnostics - coding 3. Deactive/active trailer coupling 4. Select diagnostic interface Bus 5. Follow instructions <p>Vehicle with assistance systems</p> <ol style="list-style-type: none"> 6. perform adaptation of trailer coupling on assistance systems 7. Follow instructions 8. Diagnostics 9. Read out error memory, delete if necessary 10. Done 	<p>Pour activer l'attelage, procéder de la façon suivante:</p> <ol style="list-style-type: none"> 1. Choix véhicule 2. Aller dans le diagnostic - codage 3. Activer/désactiver le diagnostic 4. Sélectionner le BUS d'interface de diagnostic 5. Suivre les instructions <p>Véhicules avec systèmes d'aide</p> <ol style="list-style-type: none"> 6. Effectuer une adaptation d'attelage aux systèmes d'aide 7. Suivre les instructions 8. Diagnostic 9. Lire la mémoire de défaut et effacer les codes d'erreur éventuellement mémorisés 10. Terminé
I	E	NL
<p>Per attivare le funzioni del rimorchio, procedere nel modo seguente:</p> <ol style="list-style-type: none"> 1. Scelta vettura 2. Passare alla Diagnosi - Codifica 3. Attivare / disattivare il gancio di traino 4. Selezionare il interfaccia di diagnosi 5. Seguire le istruzioni <p>Veicoli noc suster di assistenza</p> <ol style="list-style-type: none"> 6. adattare i suster installati 7. Seguire le istruzioni 8. Diagnosi 9. Leggere la memoria guasti e cancellare, se necessario 10. Fertig 	<p>La activación de las funciones de remolque debe la siguiente manera:</p> <ol style="list-style-type: none"> 1. Selección de vehículo 2. Cambiar a diagnosis - Codificación 3. Desactivar/ activar acoplamiento para remolque 4. Selecciona diagnosis Interface Bus 5. Seguir las instrucciones <p>En vehículos noc sistemas de asistencia</p> <ol style="list-style-type: none"> 6. Ejecutar adaptación de acoplamiento para remolque a suster de asistencia 7. Seguir las instrucciones 8. Diagnosi 9. Leer memoria de averias y borrarla si es necesario 10. Listo 	<p>De activering van de aanhangerfuncties moet als volgt worden uitgevoerd:</p> <ol style="list-style-type: none"> 1. Voertuigselectie 2. Ga naar Diagnose - Codering 3. Aanhangwagenkoppeling deactiveren/activeren 4. Diagnose interface bus selecteren 5. Volg instructie op <p>Bij voertuigen met assistentiesystemen</p> <ol style="list-style-type: none"> 6. „Aanhangwagenkoppeling aanpassen aan assistentiesystem“ uitvoeren 7. Volg instructie op 8. Diagnose 9. Foutcodegeheugen uitlezen en indien nodig wissen 10. Gereed

50 CHECK

OPTION vehicle coding

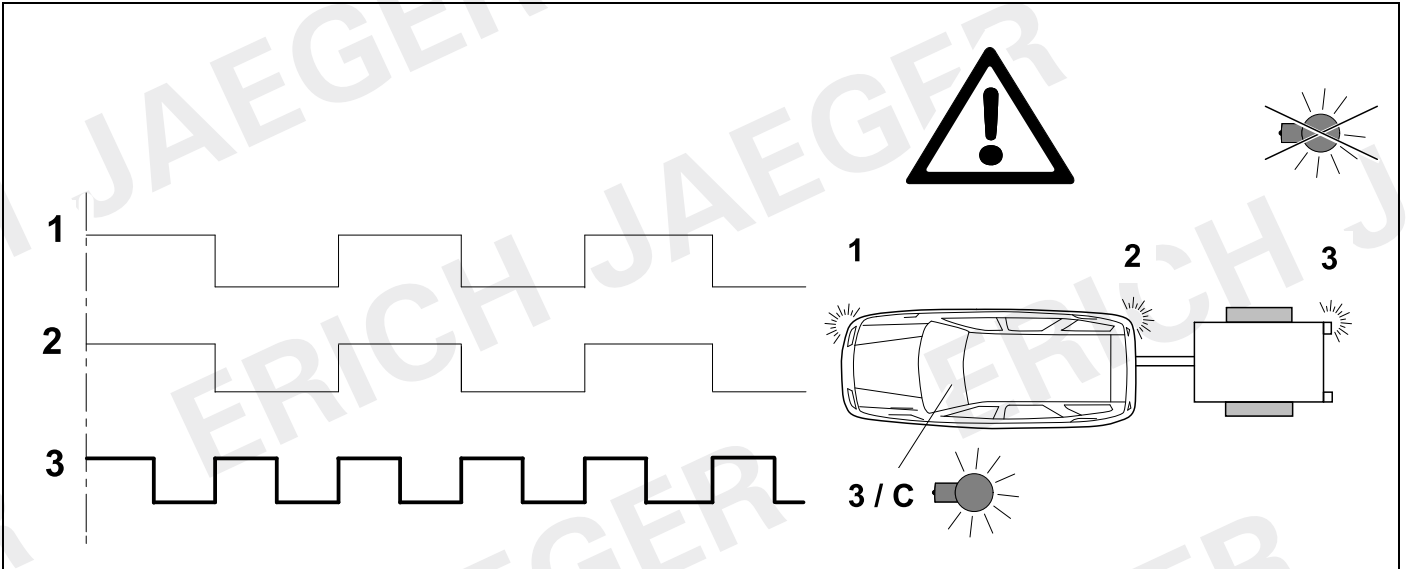

51

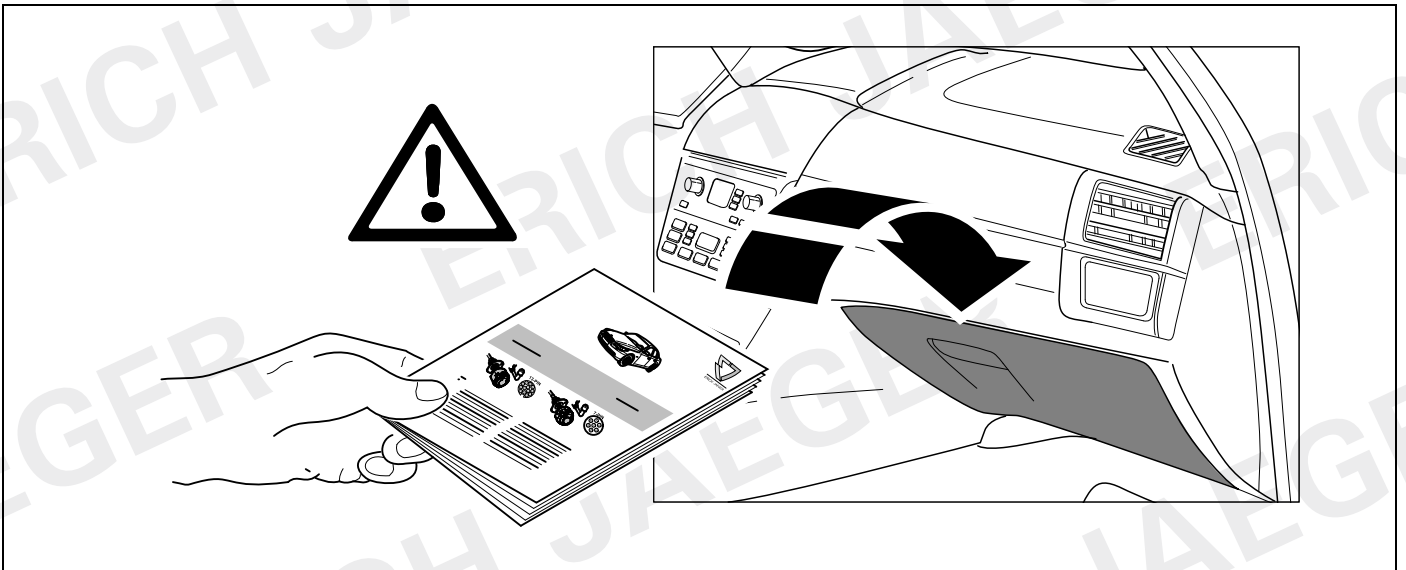

52

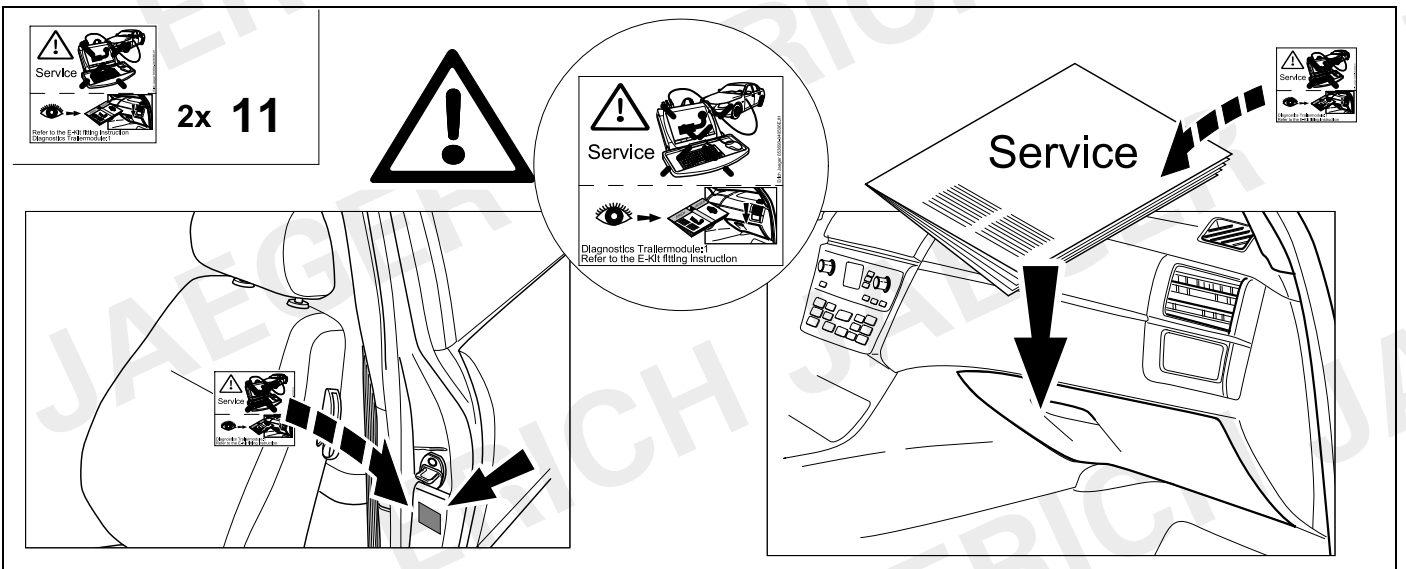

ERICH JAEGER

ERICH JAEGER

D	Änderungen bezüglich Konstruktion, Ausstattung Farbe sowie Irrtum vorbehalten. Angaben und Abbildungen unverbindlich	PL	Zastrzega się prawo do zmian dot. konstrukcji, wykończenia, kolorystyki oraz pomyłek. Dane i ilustracje niewiążące.
GB	Subject to change in terms of construction, equipment and colour, and may contain errors. The information and illustrations are non-binding.	TR	Tasarım, donanım ve renk bakımından değişiklik yapma hakkı ve hata ve eksiklik mahfuzdur. Veriler ve resimler bağlayıcı değildir.
F	Sous réserve de modifications de la construction, de l'équipement, de la couleur et sous réserve d'erreurs. Les indications et les illustrations sont sans engagement.	H	A szerkezet, a kivétel és a szín változtatása, valamint a változások joga fenntartva. Az adatok és az ábrák nem kötelező érvényűek.
NL	Wijzigingen met betrekking tot constructie, uitvoering en kleur evenals vergissingen voorbehouden. Gegevens en afbeeldingen niet bindend.	HR	Pravo promjena u svezi konstrukcije, opreme, boje kao i zabune oridžavamo. Podaci i ilustracije su neobavezne.
DK	Ændringer med hensyn til konstruktion, udstyr, farver samt fejl forbeholdes. Oplysninger og illustrationer er uforpligtende.	BUL	Запазени права по отношение на конструкцията, оборудването, цвета и грешки. Данните и изображенията не са обвързващи.
N	Ændringer angående konstruksjon, utstyr, farge og feiltagelse forbeholdes. Oplysninger og illustrasjoner uforbindtlig.	RO	Ne rezervăm dreptul unor modificări ale construcției, dotării, culorii și dreptul la erori Datele indicate și imaginile sunt orientative.
S	Med reservation för ändringar vad det gäller konstruktion, utrustning, färg samt för misstag. Uppgifterna och bilderna är inte bindande.	RU	Права на внесение изменений относительно конструкции, оснащения, окраски, а также на ошибки сохраняются. Данные и иллюстрации имеют примерный характер.
FIN	Pidätämme oikeuden rakennetta, varustusta, väriä koskeviin sekä erehdyksestä johtuviin muutoksiin. Tiedot ja kuvat eivät ole sitovia.	LT	Pasilieikama konstrukcijos, įrangos bei reikmenų, spalvos pakeitimų ir klaidų teisė. Duomenys ir iliustracijos neįpareigojantys.
I	Con riserva di modifiche relative a progettazione, dotazione, colore ed errori. Le indicazioni e figure sono fornite senza impegno.	LV	Tiek paturētas tiesības uz konstrukcijas, iekārtu, krāsu izmaiņām, kā arī kļūdišanās. Dati un attēli bez saistībām.
E	Reservadas las modificaciones respecto a diseño, equipamiento, color, así como error. Indicaciones y figuras sin compromiso.	EST	Konstruktsooni, varustuse ja võervi osas muudatused ning eksimine lubatud. Andmed ja joonised on mittesiduvad.
P	Reservamos o direito de alterações relativamente ao desenho, equipamento, cor, bem como de erro. Os dados e as gravuras não implicam compromisso da nossa parte.	SLO	Zadržana pravica do sprememb glede konstrukcije, opreme, barve ter pomote. Podatki in slike so neobvezne.
GR	Διατηρώνουμε κάθε επιφύλαξη ως προς αλλαγές σε σχέση με κατασκευή, εξοπλισμό, διαρρύθμιση, χρωματισμούς και λάθη παραδρομής.	SK	Zmeny, ktoré sa týkajú konštrukcie, vybavenia, farby, ako aj omyly sú vyhradené. Údaje a zobrazenia sú nezáväzné.
CZ	Změny, týkající se konstrukce, vybavení, barvy, jakož i omyly jsou vyhrazeny. Údaje a vyobrazení jsou nezávazné.		

ERICH JAEGER Artikelnummer:
ERICH JAEGER part number:

311105

