

---

Fitting instructions

---

Make : Toyota

---

AVENSIS VERSO; 2001 ->

---

Type : 3581

---

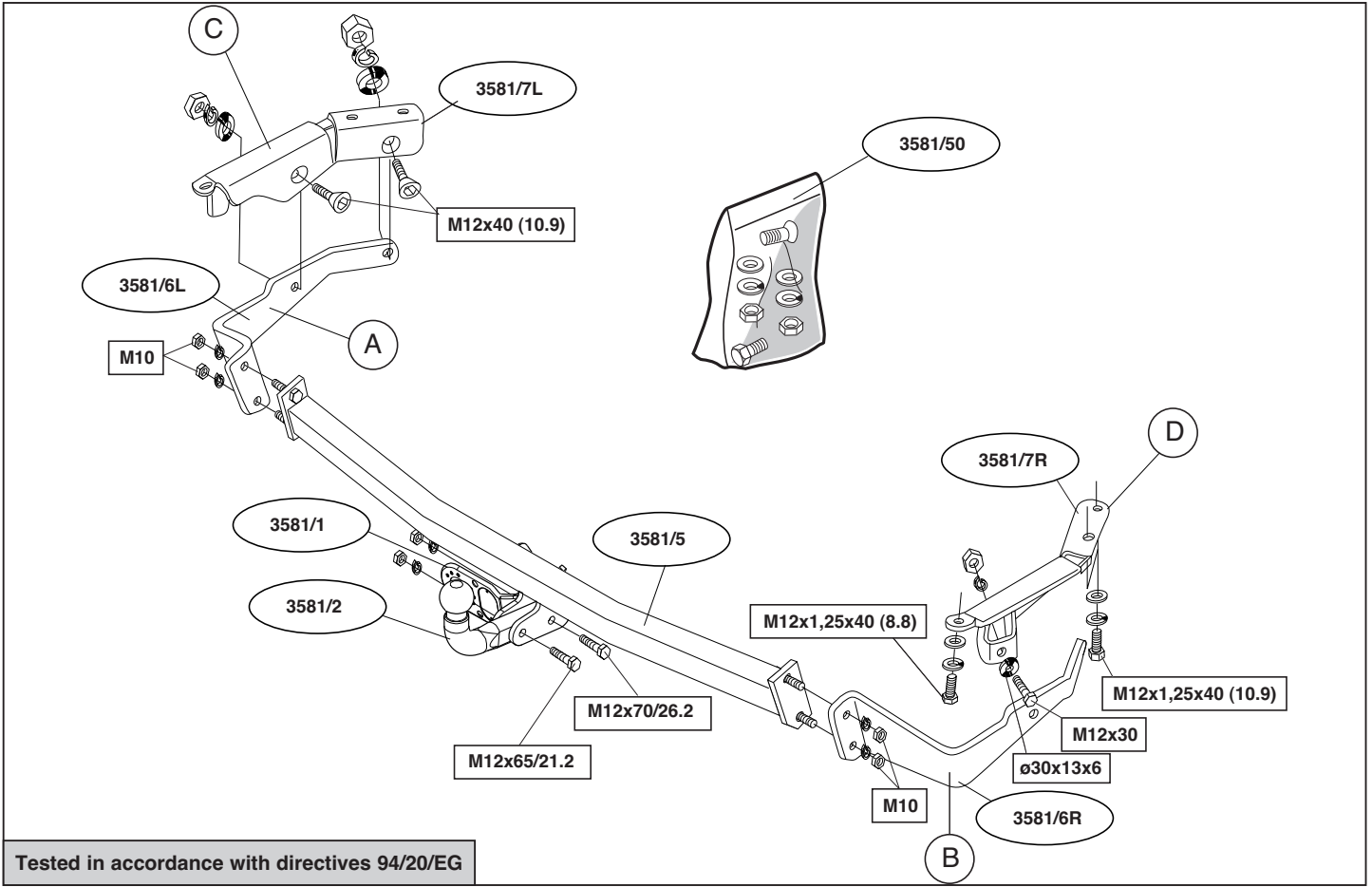

Tested in accordance with directives 94/20/EG

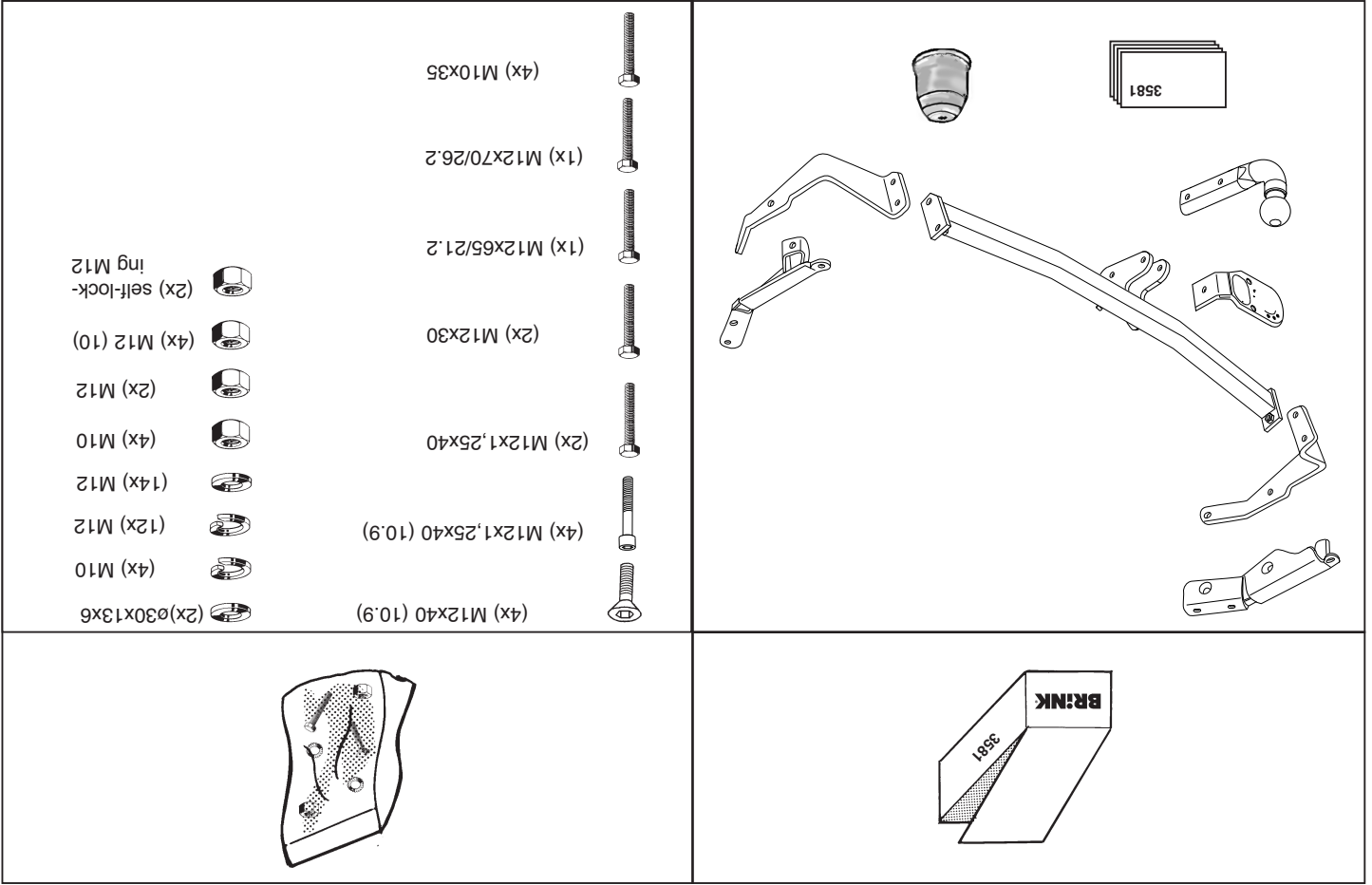

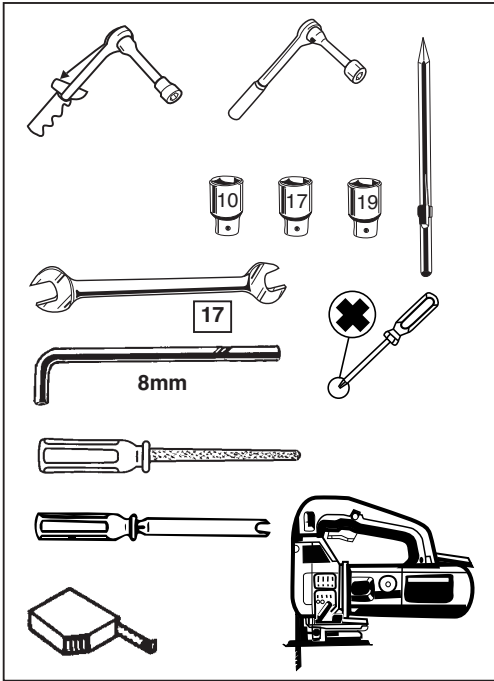

±5%

**D-value**

$$D = \frac{2250 \text{ K.G max} \times 1600 \text{ K.G max}}{2250 \text{ K.G max} + 1600 \text{ K.G max}} \times \frac{9.81}{1000} = 9.70 \text{ kN}$$

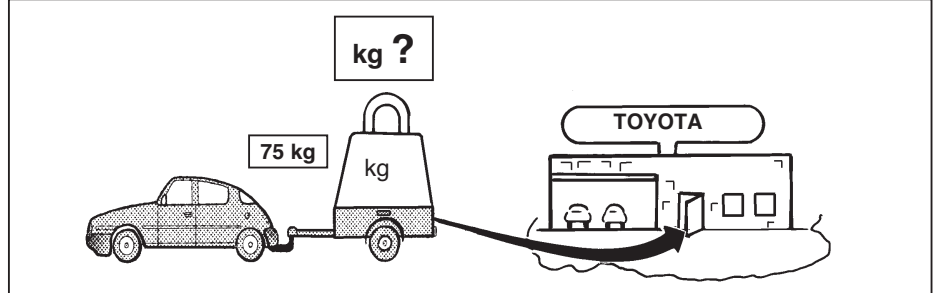
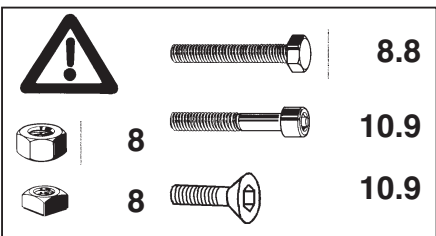
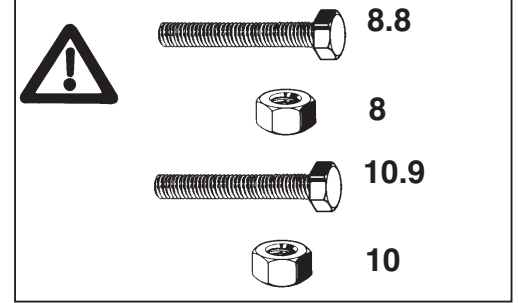
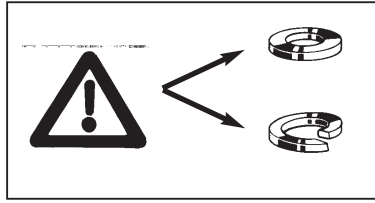

© 358170/19-11-2001/3



**Istruzioni da conservare**

Dispositivo di traino tipo: P.C. Brink 3581  
 Per autoveicoli: Toyota AVENSIS VERSO  
 Tipo funzionale:  
 Classe e tipo di attacco: A50-X  
 Approvazione N.: e11 00-3017  
 Valore D: 9,70 kN  
 Carico max. verticale S: 75 kg  
 Larghezza rimorchiabile: Per il triano di caravans o TATS e' consentita una larghezza di 2.50 m vedi carta di circolazione dell' autoveicolo  
 Massa rimorchiabile:

**DICHIARAZIONE DI CORRETTO**

**MONTAGGIO**.....li.....  
 Si dichiara che il dispositivo di attacco tipo.....  
 In fede è stato installato sull' auto veicolo.....  
 .....targa.....  
 in conformità alle prescrizioni sia del costruttore del veicolo che del costruttore del dispositivo stesso.

**BRiNK**

type nr. **3581** art. nr. \_\_\_\_\_  
 ser. nr. \_\_\_\_\_  
 coupling class **A50-X**  
 approval number **e11 00-3017**  
 d-value **D 9,7** kN  
 vert. load part nr. **S 75** kg

made by **BRiNK**

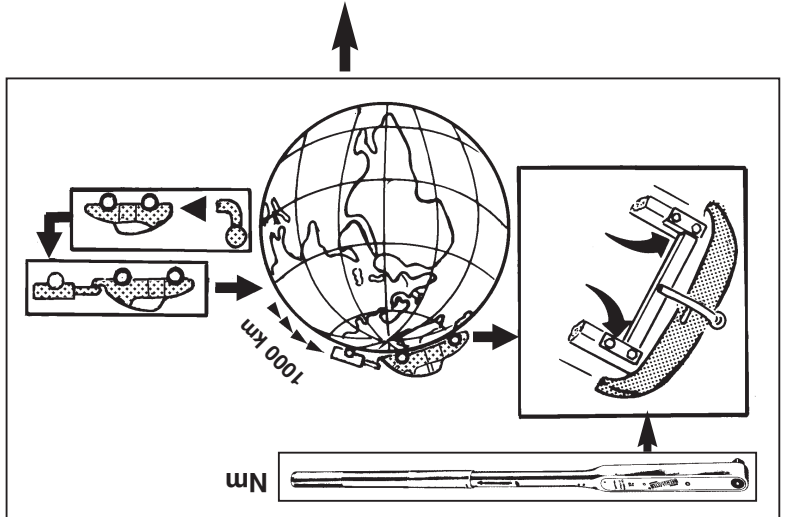
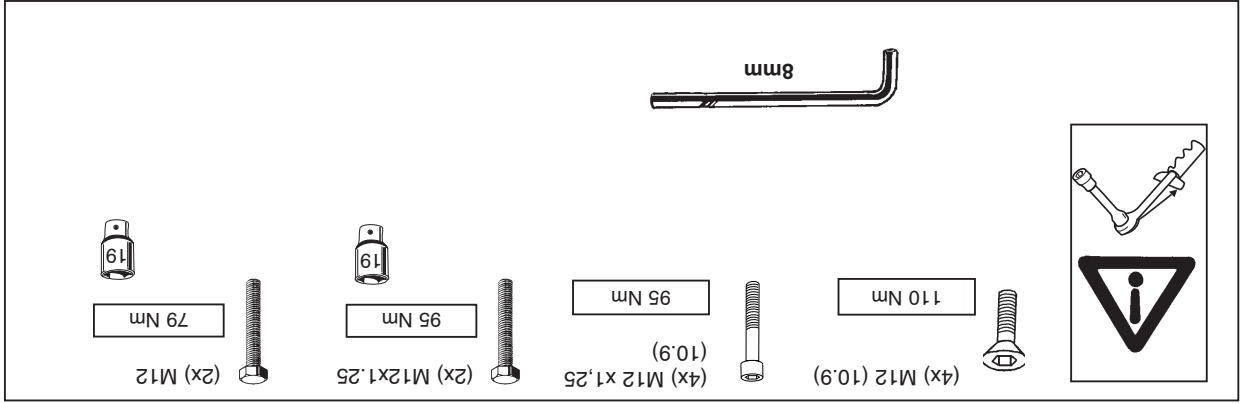
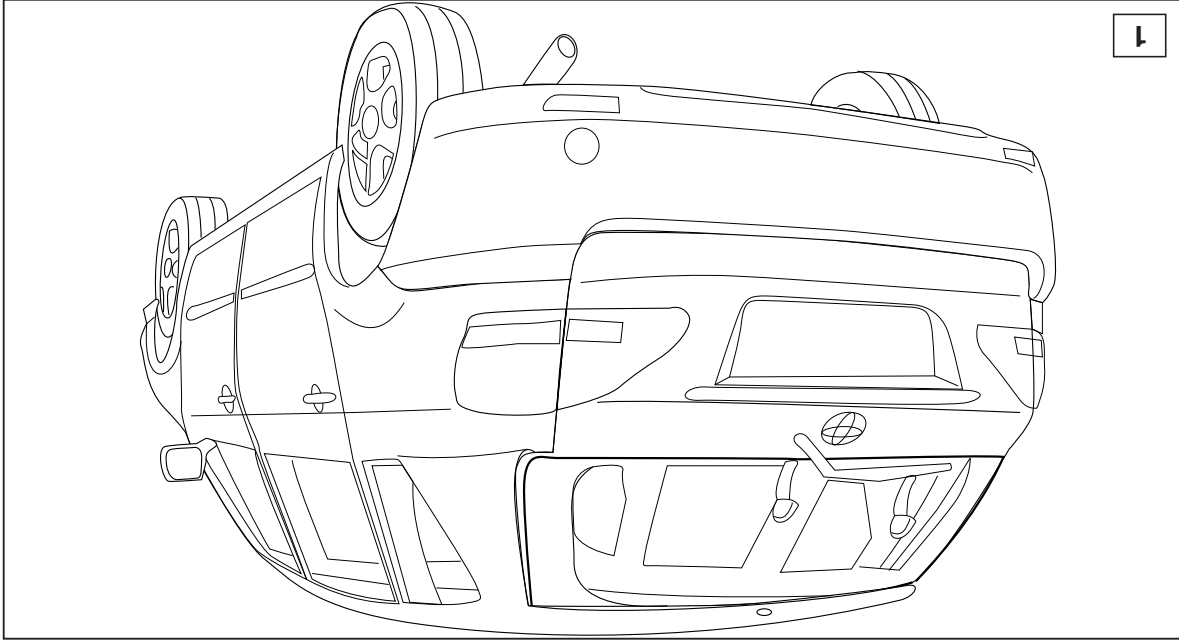

**HINWEISE:**

- \* Die für das Fahrzeug zugelassene Anhängelast ist den Fahrzeug Unterlagen zu entnehmen. Bei Änderungen des Fahrzeuggewichtes muß die höchstzulässige Anhängelast gegebenenfalls aus dem D-Wert nachgerechnet werden.
- \* Auskunft hierüber kann ihr Fachhändler oder der TÜV geben.
- \* Elektrische Anlage gemäß StVZO anbringen.

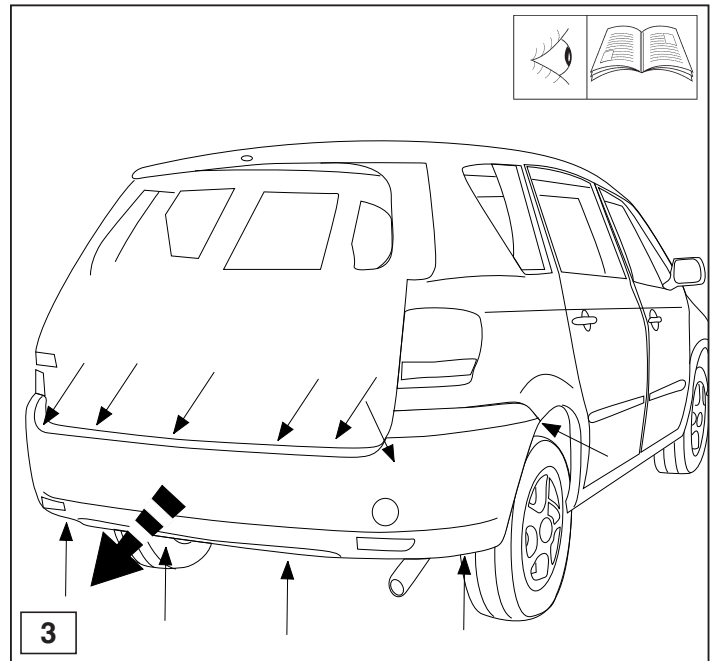
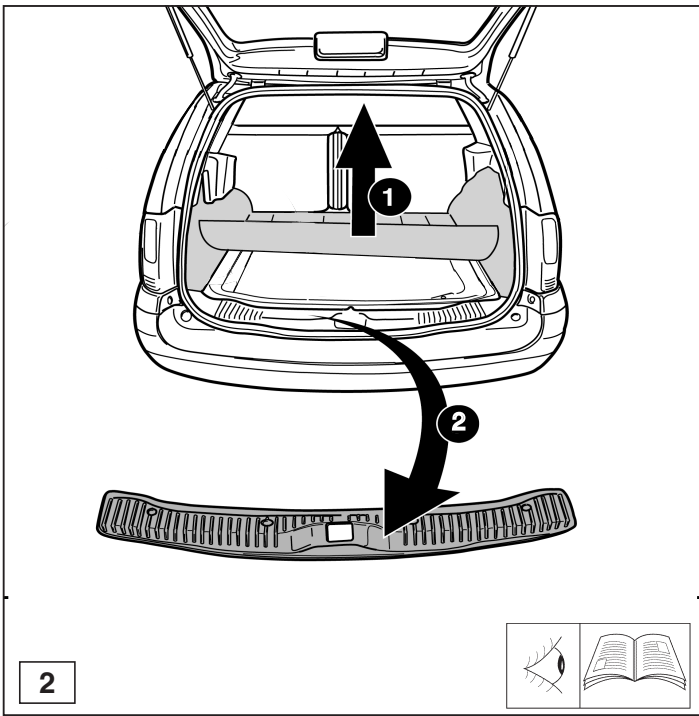

© 358170/19-11-2001/5

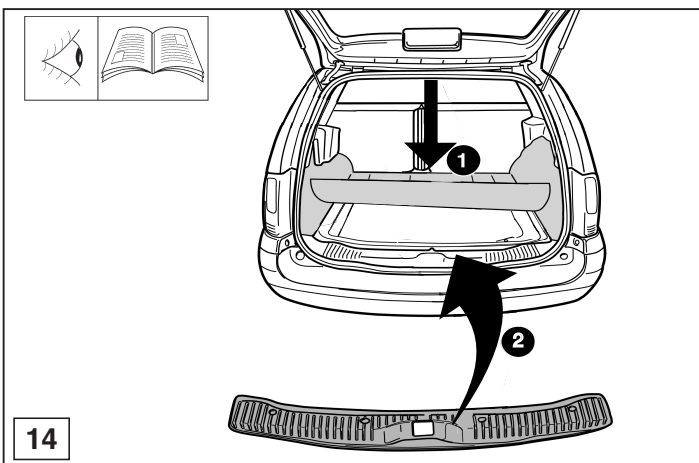
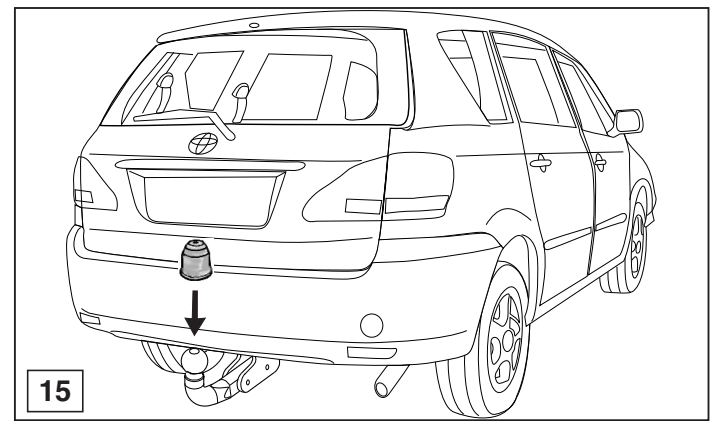
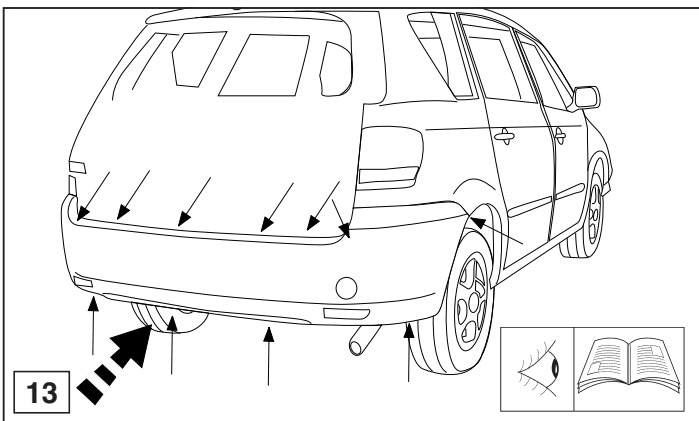

© 358170/19-11-2001/10

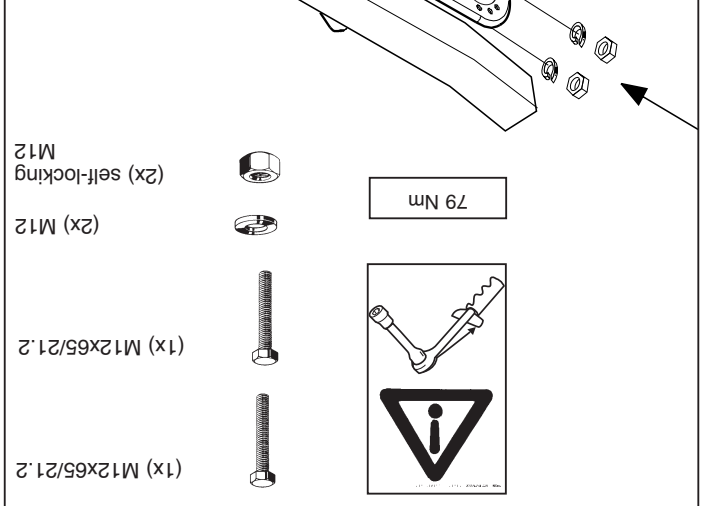
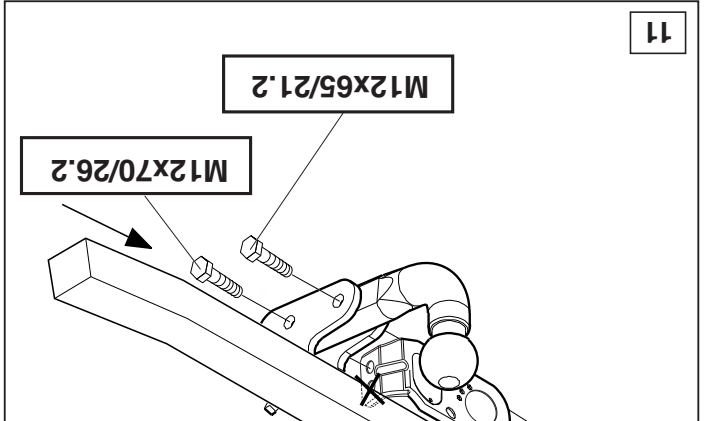
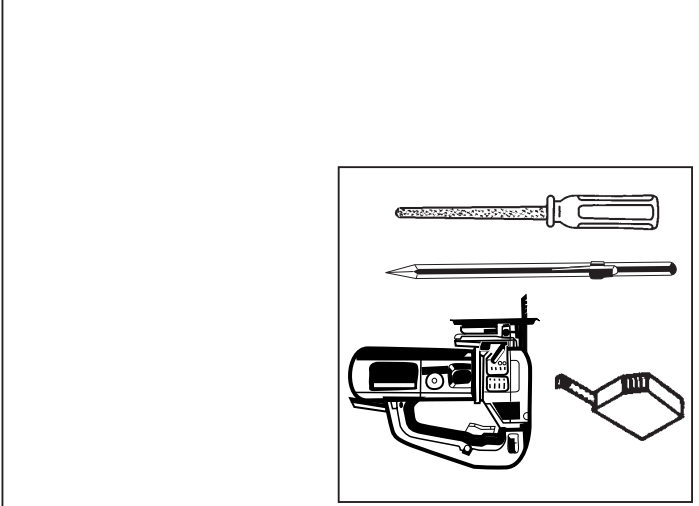
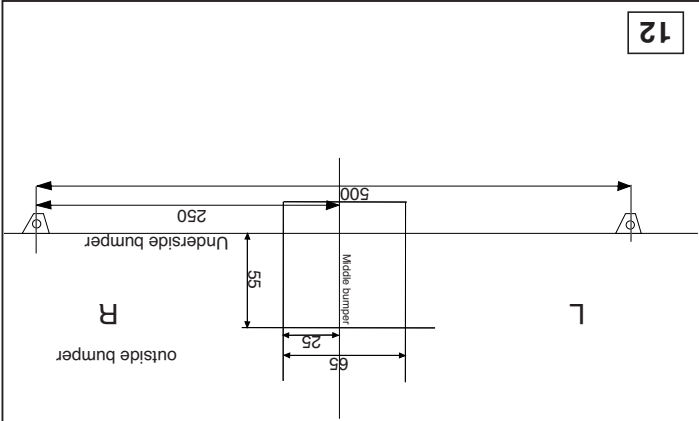
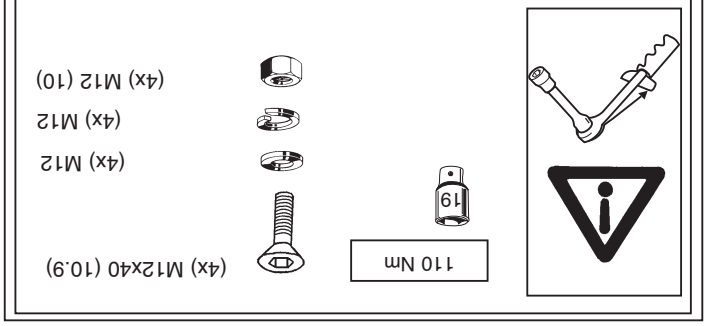
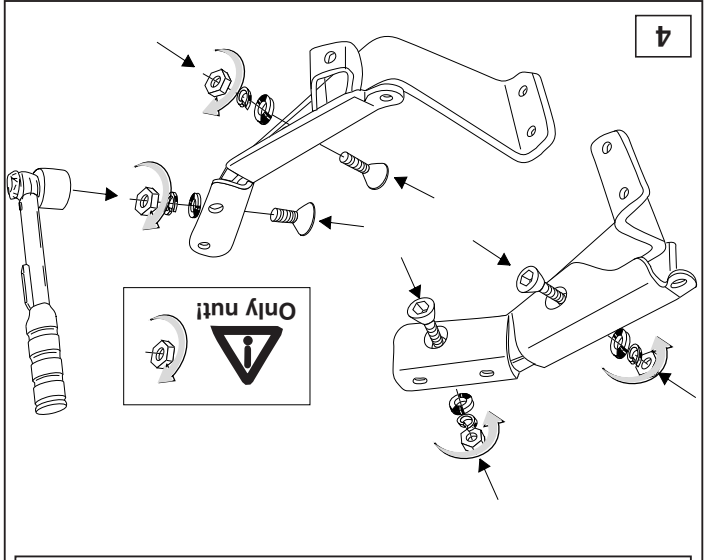
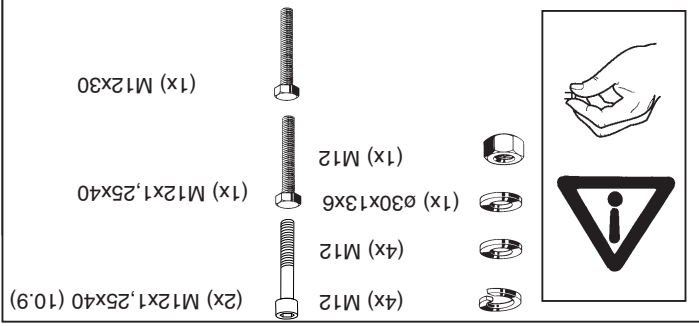
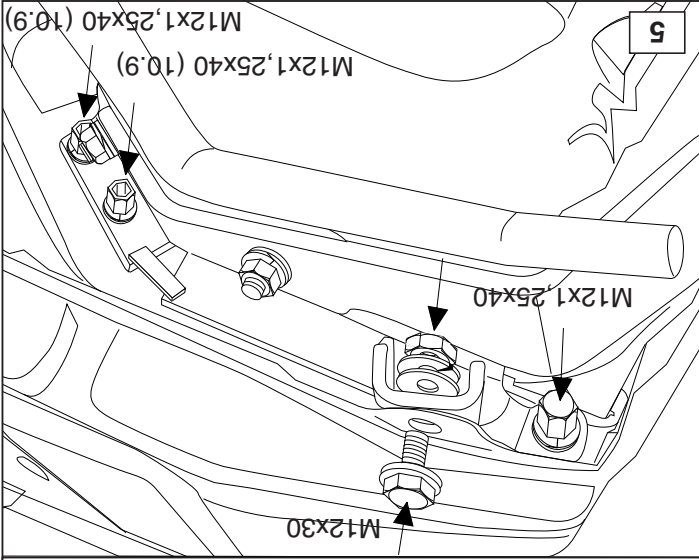

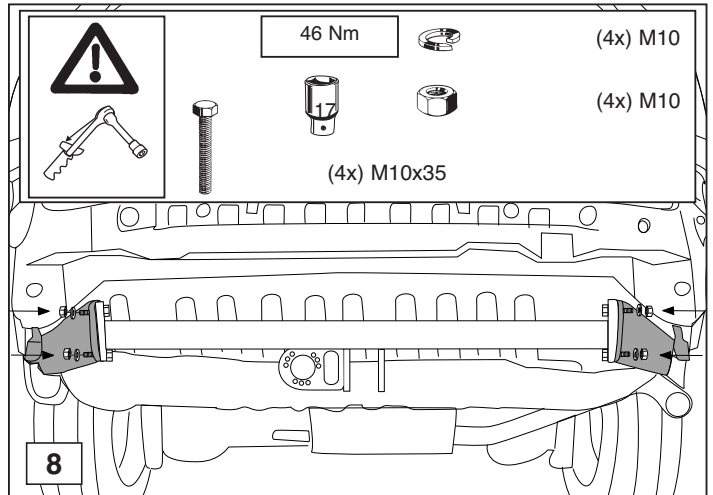
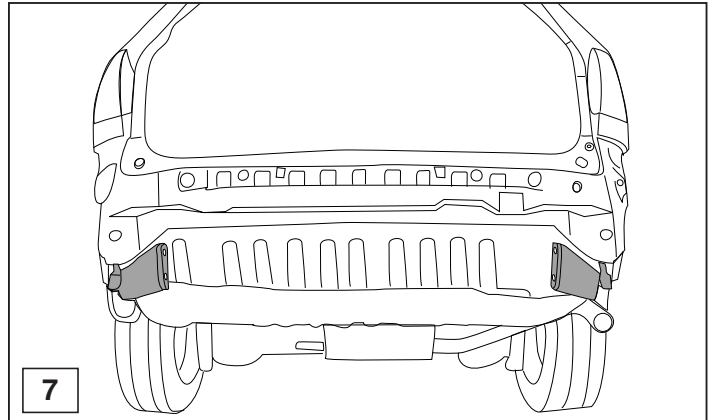
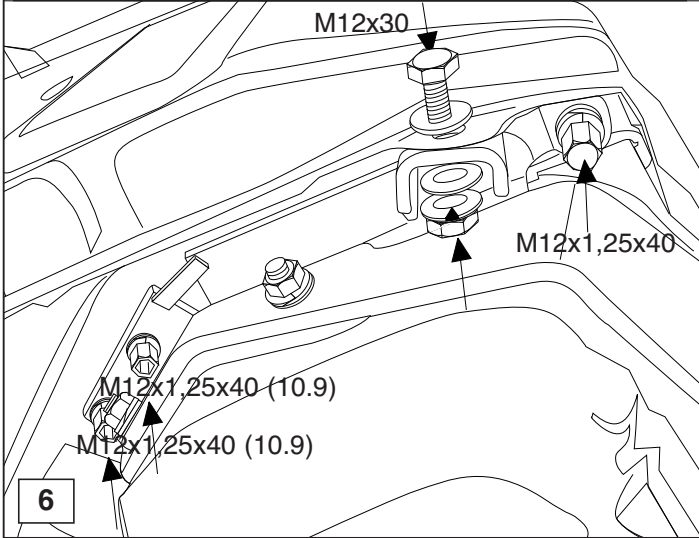
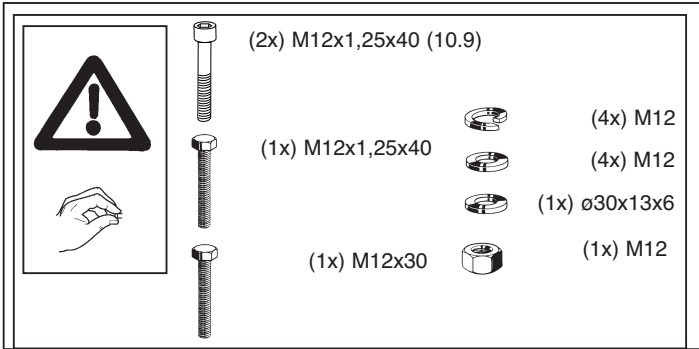

© 358170/19-11-2001/7

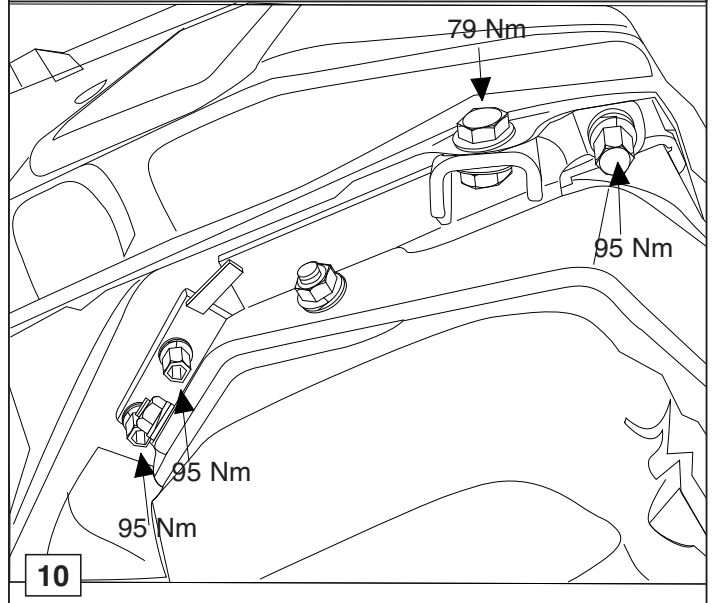
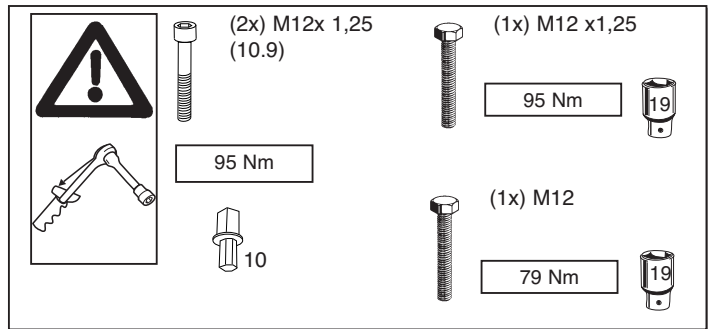
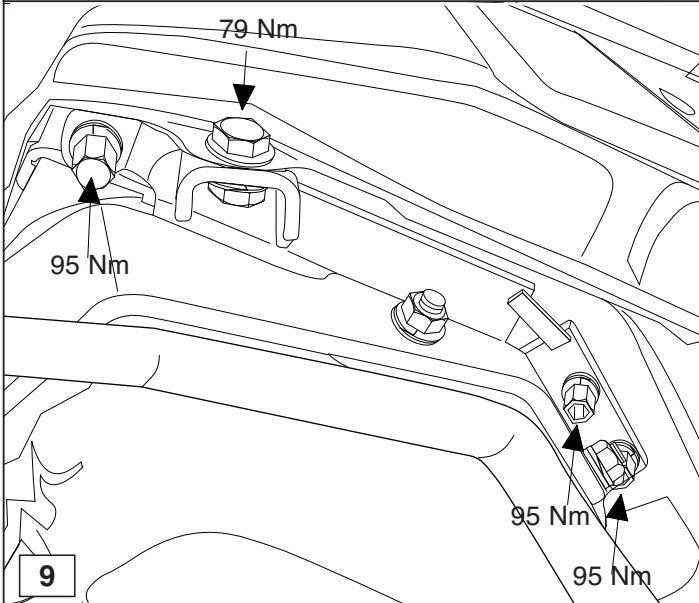
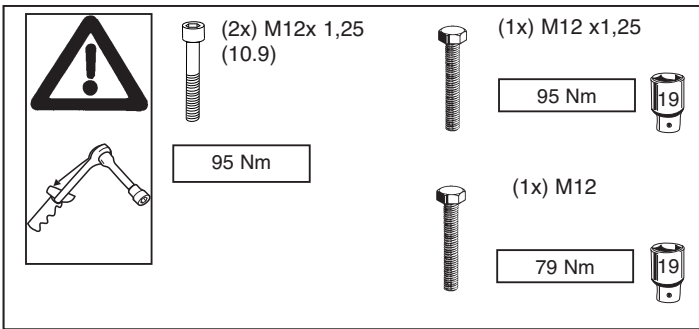

© 358170/19-11-2001/8