

Fitting instructions

Make: Toyota

Auris; 2006->

Type: 5299

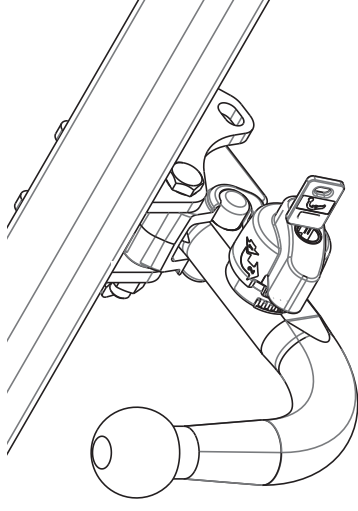

ser.nr:

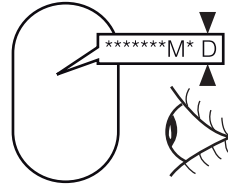



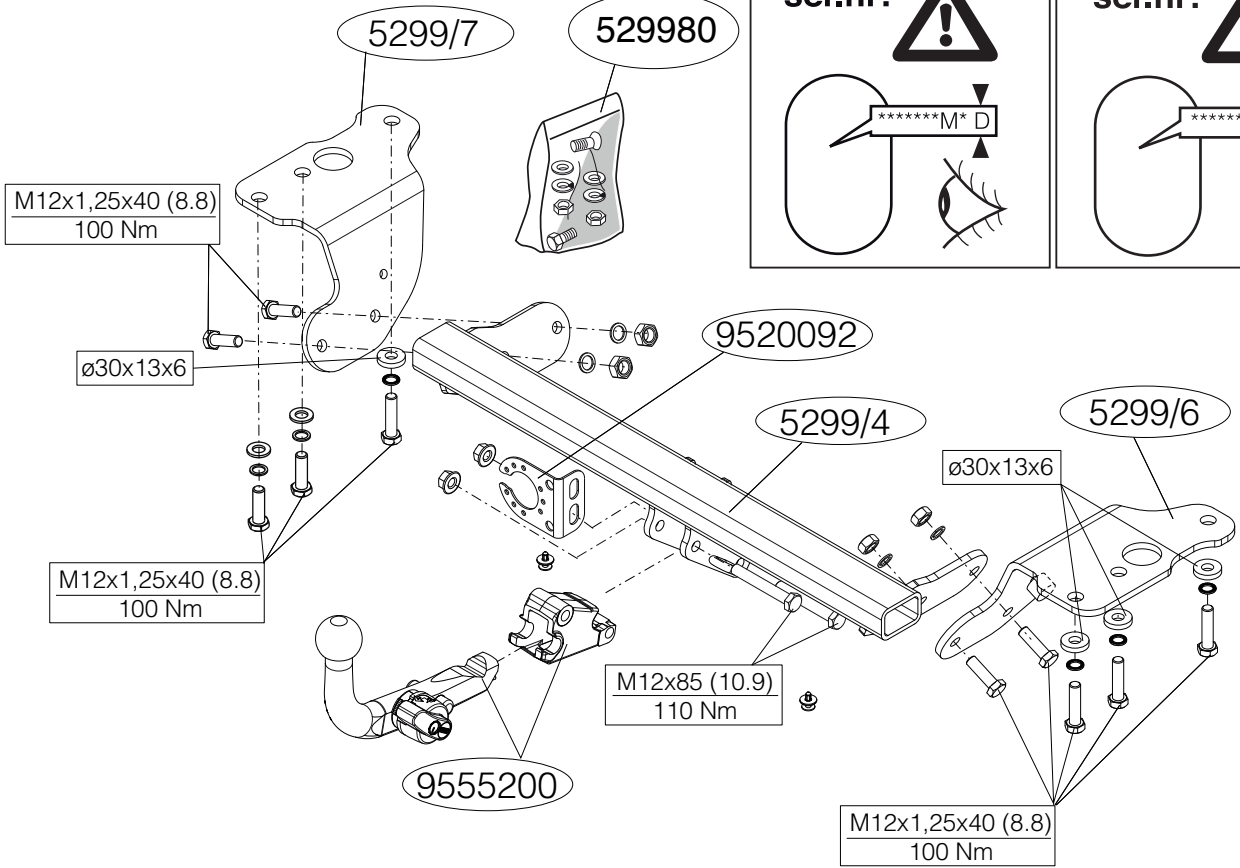
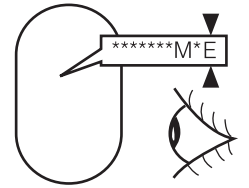



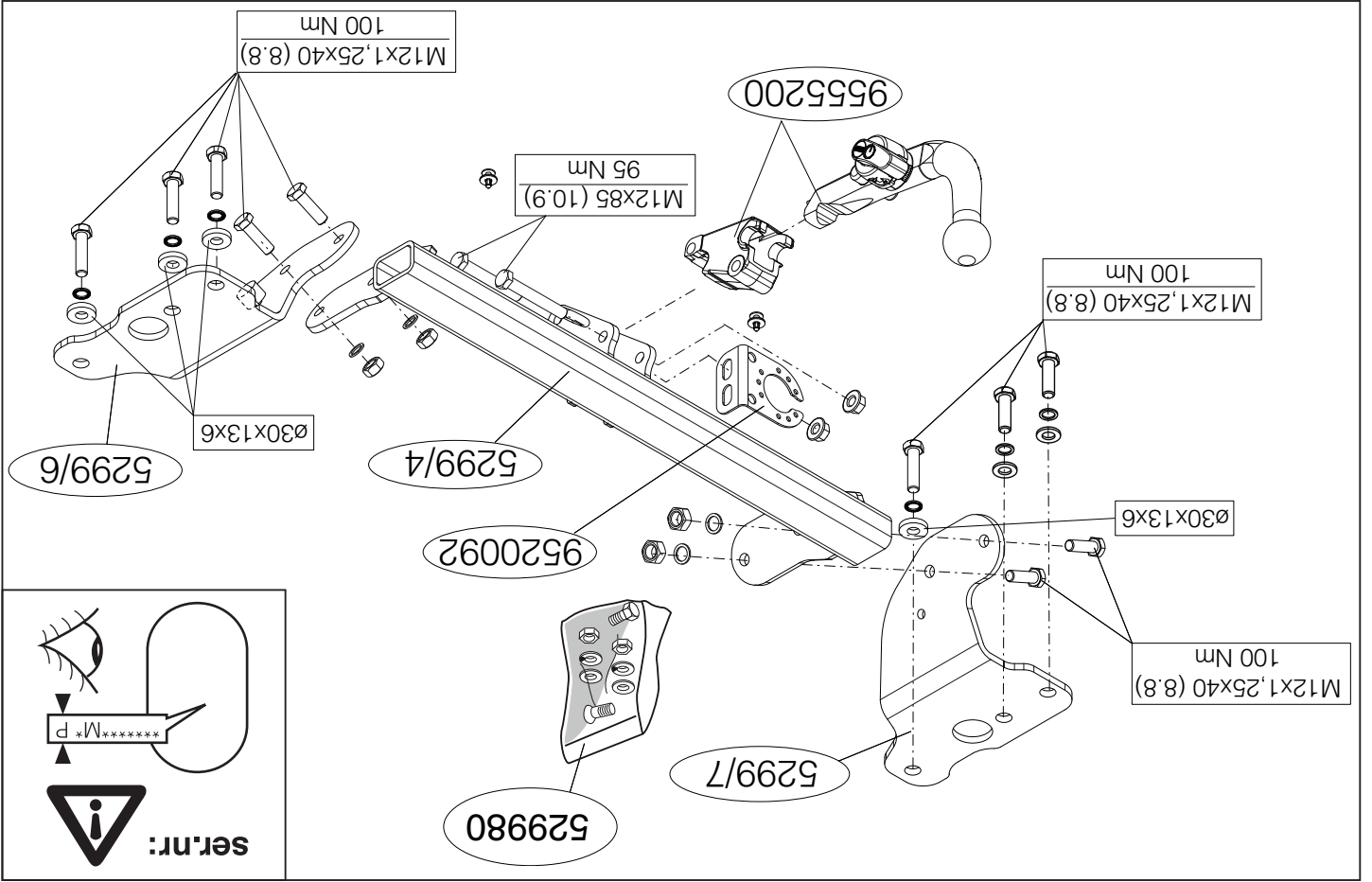

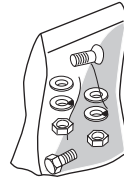
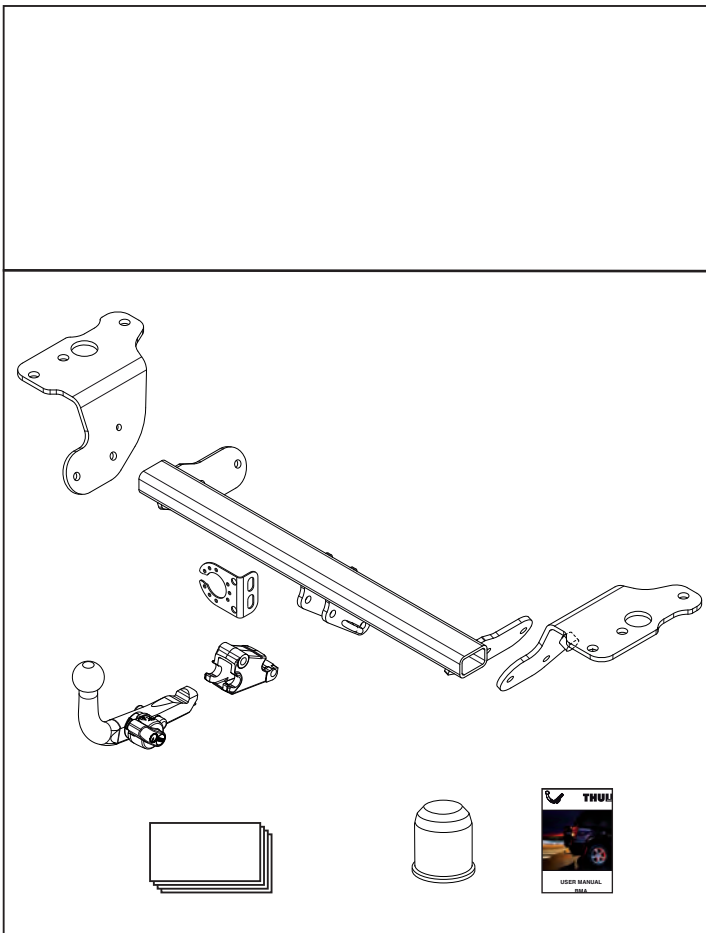
ser.nr:



© 529970/12-04-2010/1





-  (10x) M12x1.25X40 (8.8)
-  (2x) M12x85 (10.9)
-  (2x) self locking M12
-  (10x) M12
-  (2x) M12
-  (4x) $\varnothing 30 \times 13 \times 6$
-  (4x) M12x1.25
-  (2x)

© 529970/12-04-2010/3

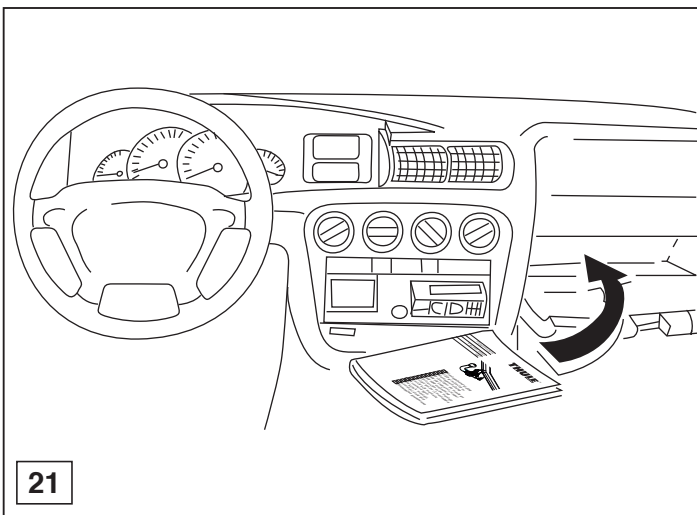

21

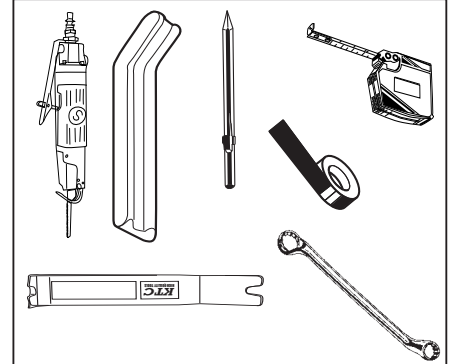
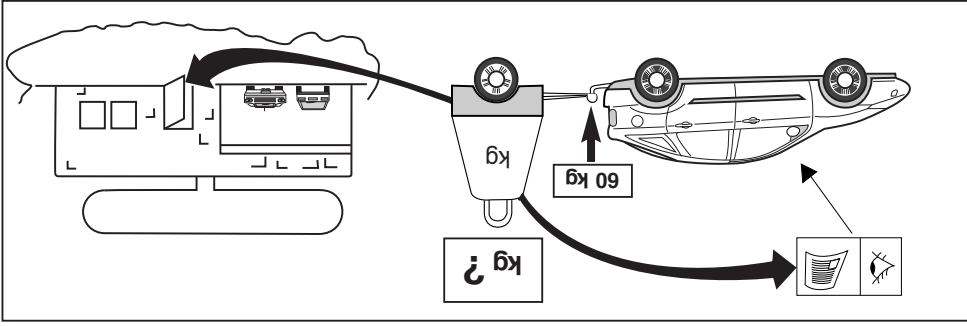
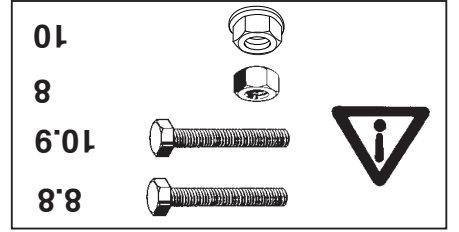
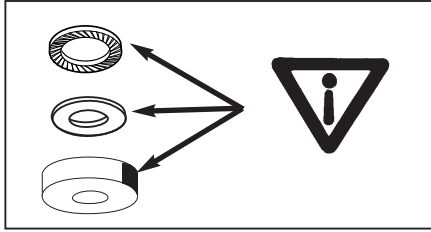
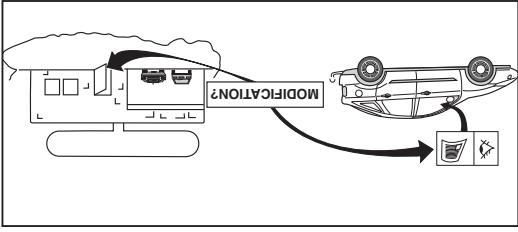

D-Value : 8,6 kN

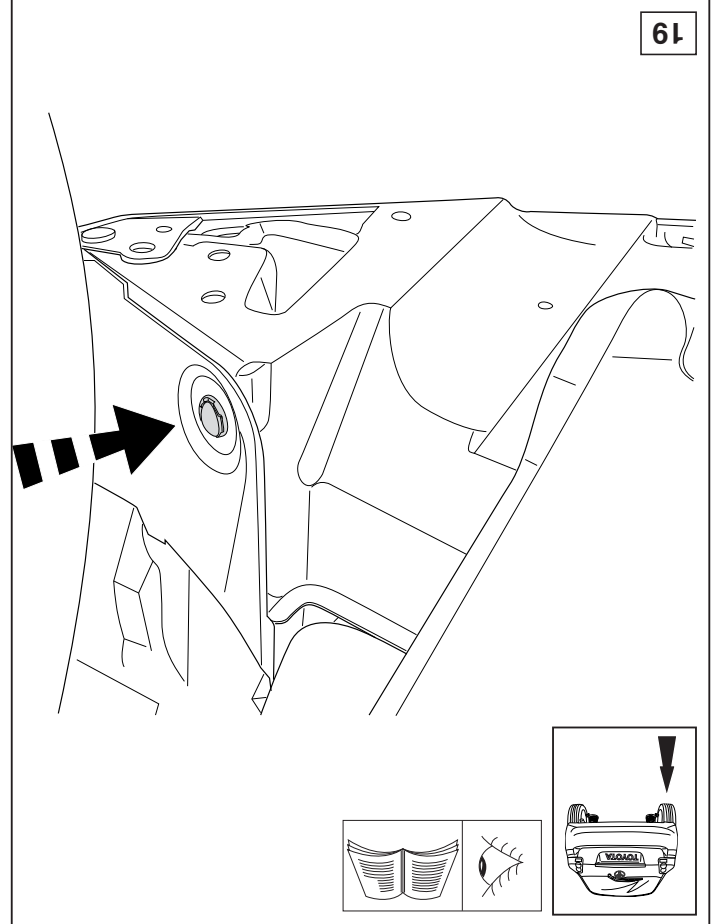
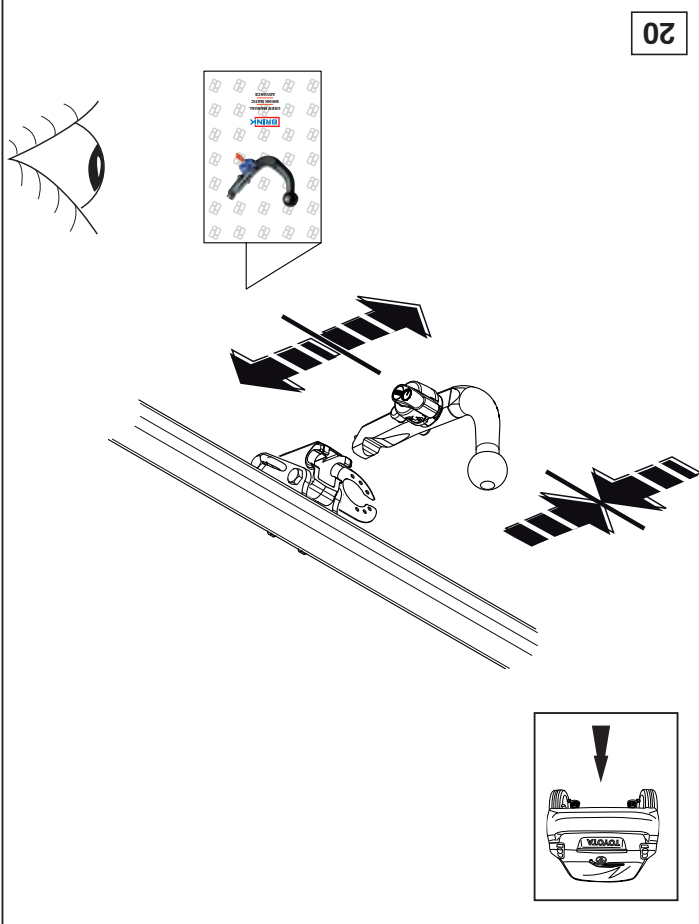
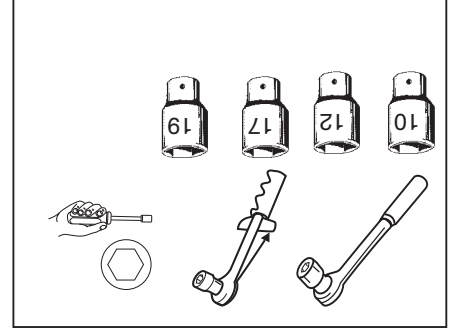
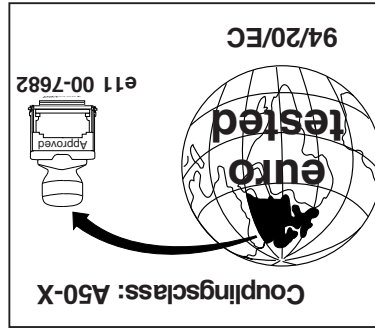



NOTE:

* Should this installation process entail the cutting of the bumper – conformation **MUST** be obtained by the installation engineer of the customer's acceptance prior to completion. Brink International do not accept responsibility for any matters arising as a result of this miscommunication.

HINWEISE:

* Die für das Fahrzeug zugelassene Anhängelast ist den Fahrzeug Unterlagen zu entnehmen. Bei Änderungen des Fahrzeuggewichtes muß die höchstzulässige Anhängelast gegebenenfalls aus dem D-Wert nachgerechnet werden.

Auskunft hierüber kann Ihr Fachhändler oder der TÜV geben.

* Elektrische Anlage gemäß StVZO anbringen.

© 529970/12-04-2010/5

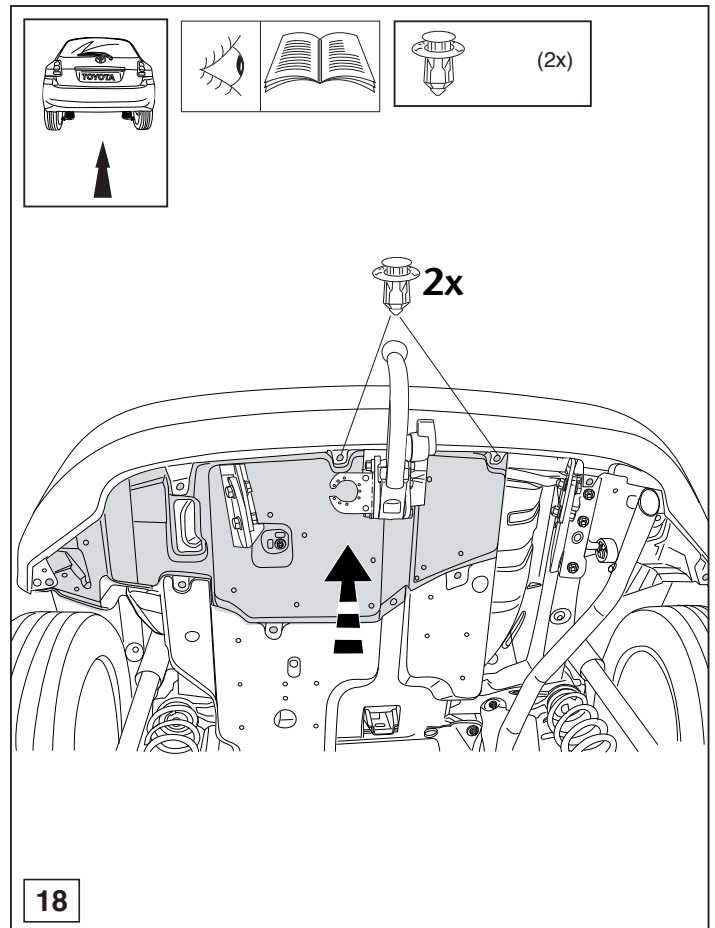
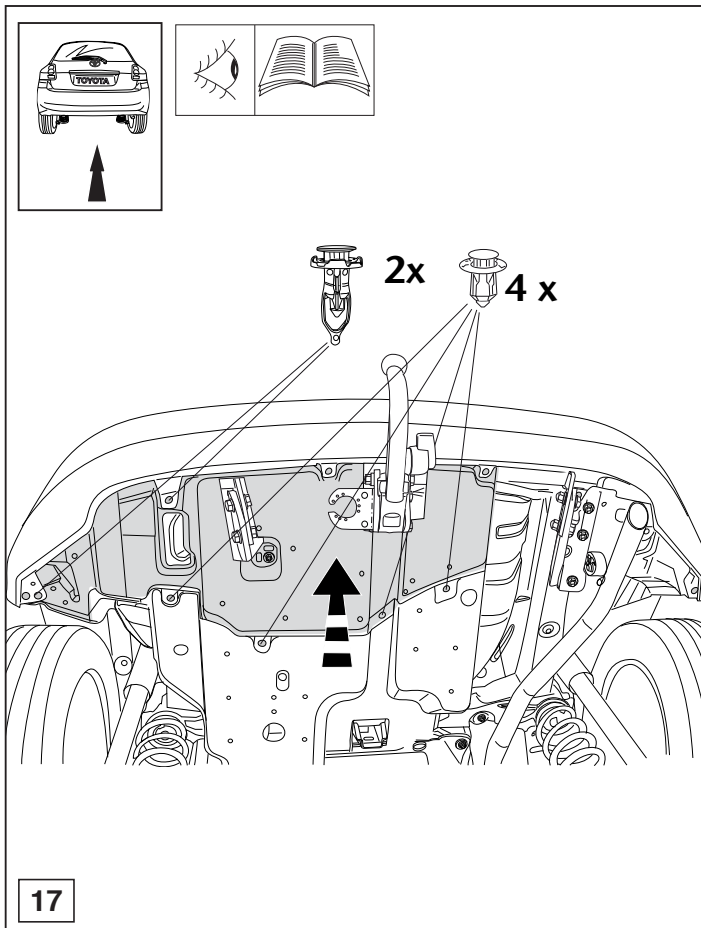

© 529970/12-04-2010/14

2

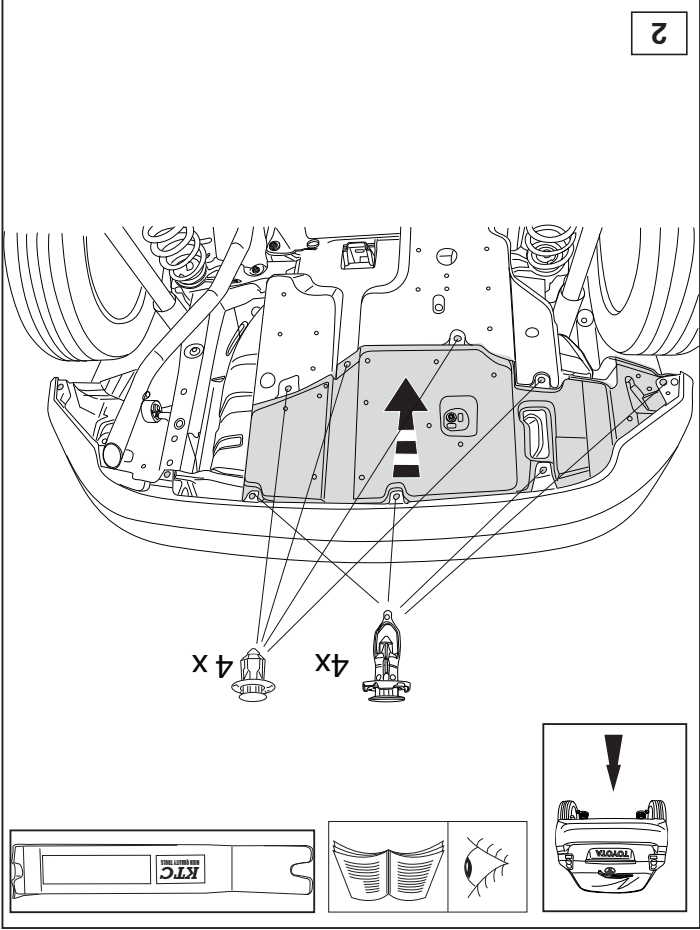

1

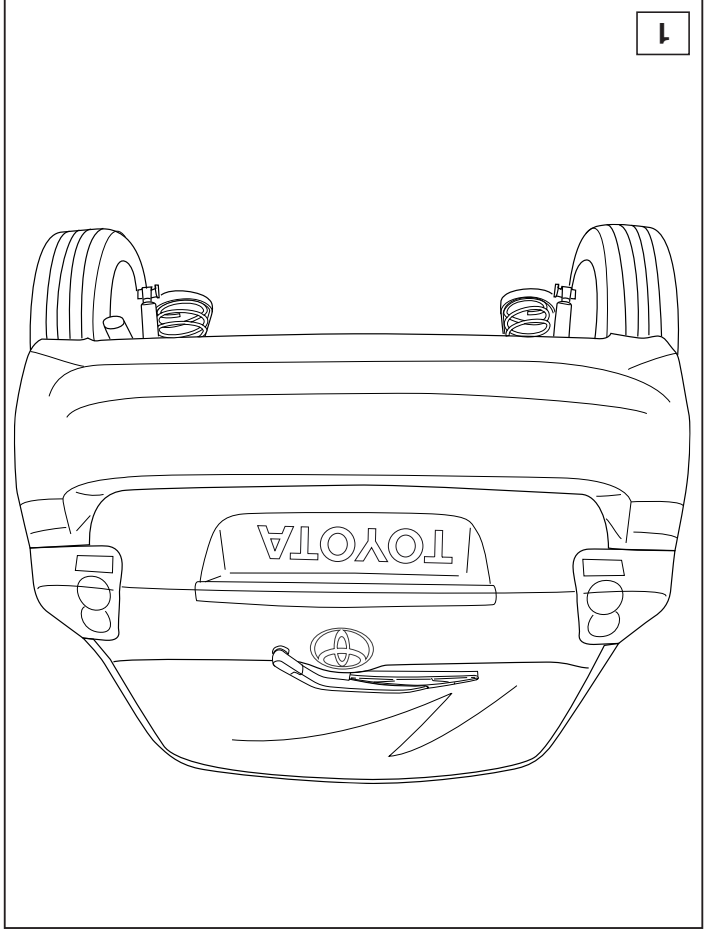

16

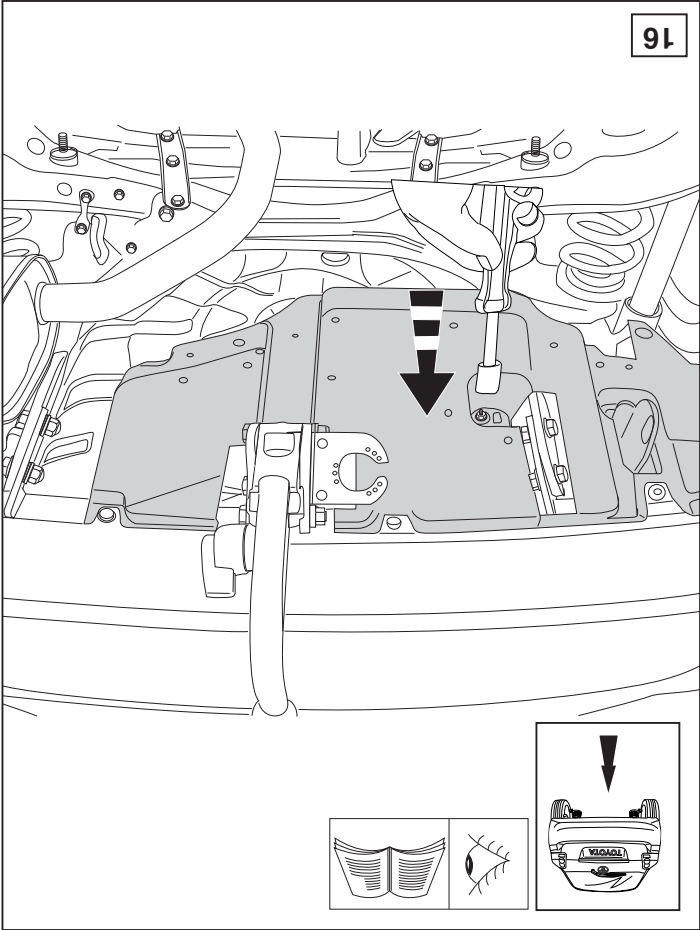

15

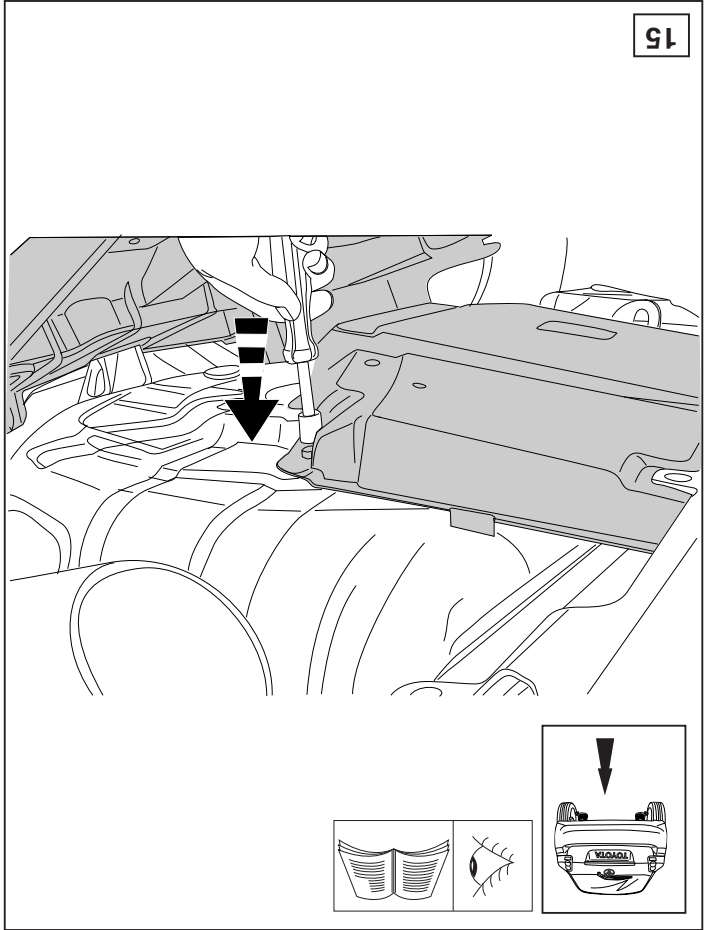

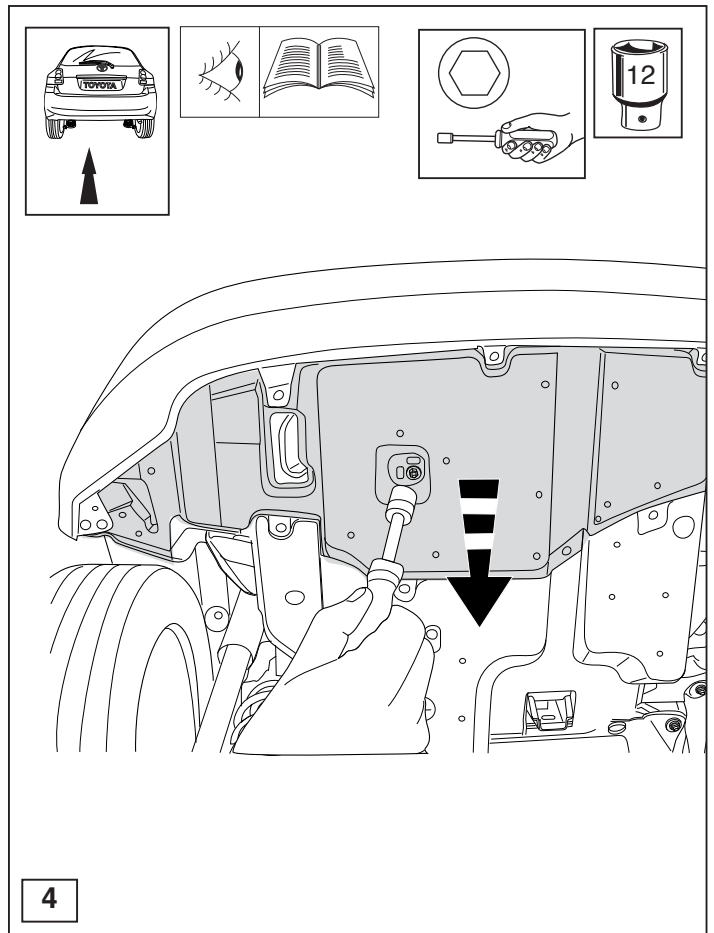
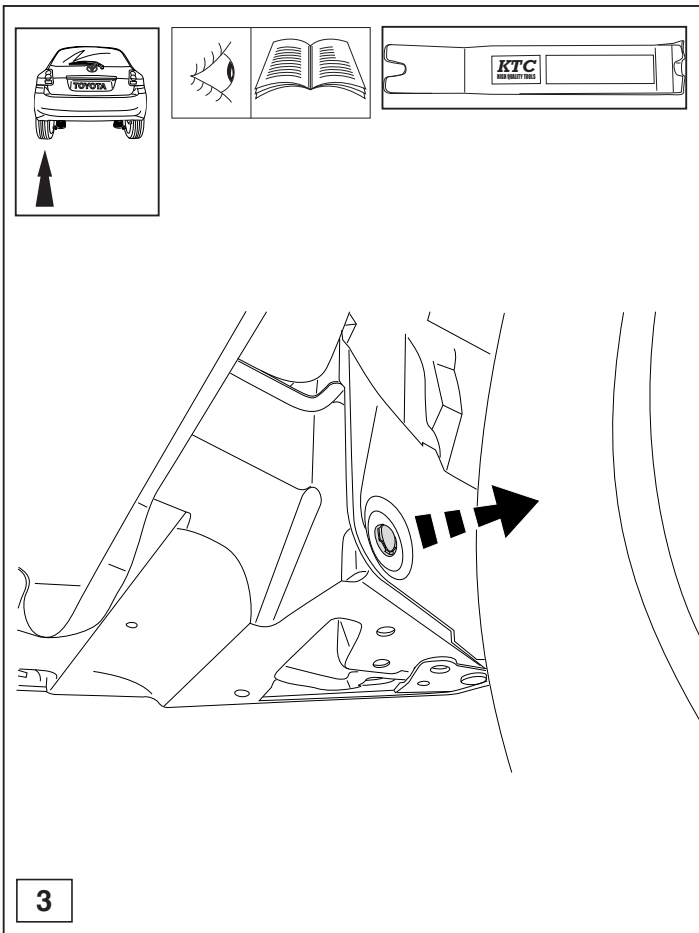

© 529970/12-04-2010/7

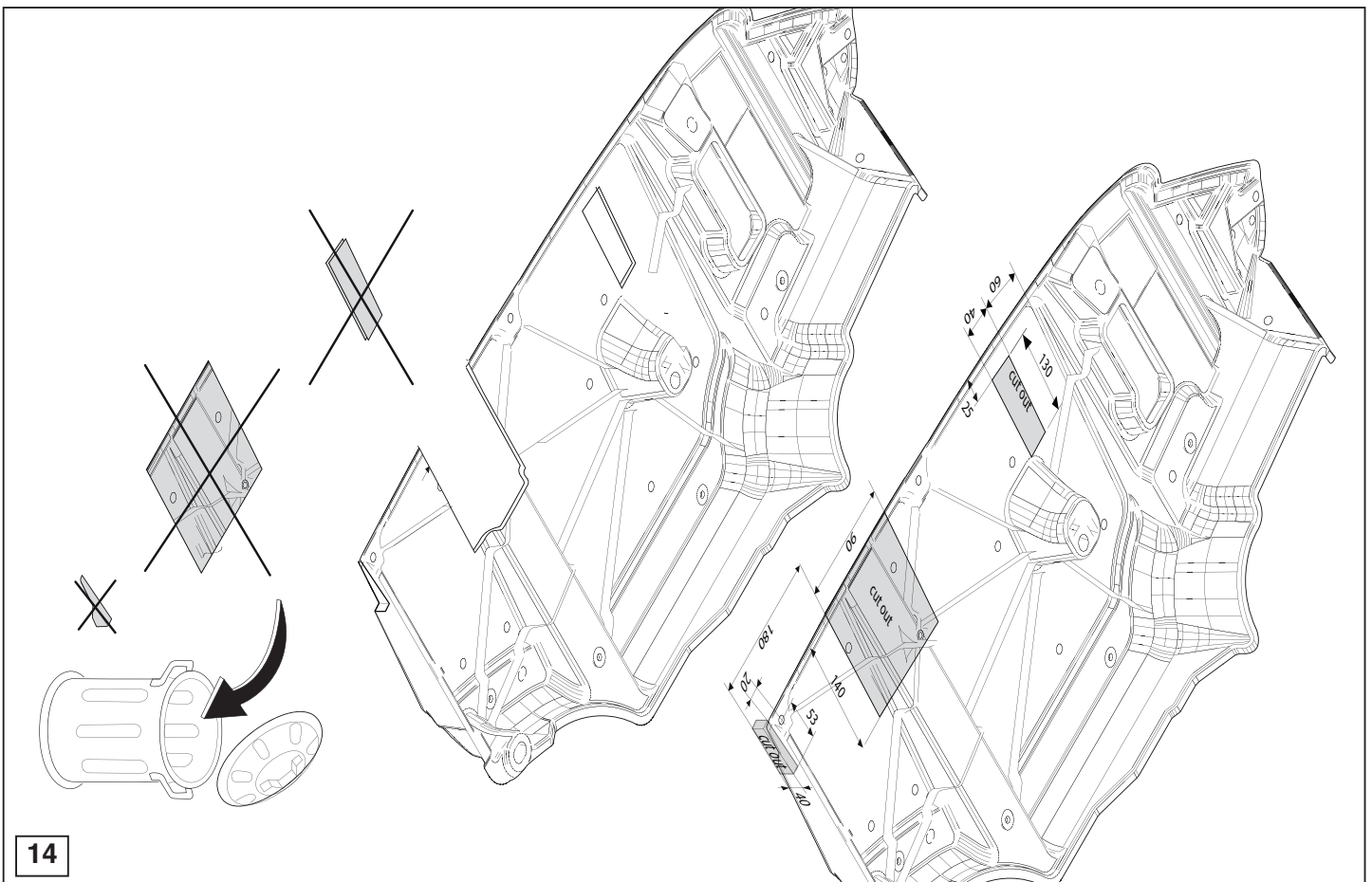

© 529970/12-04-2010/12

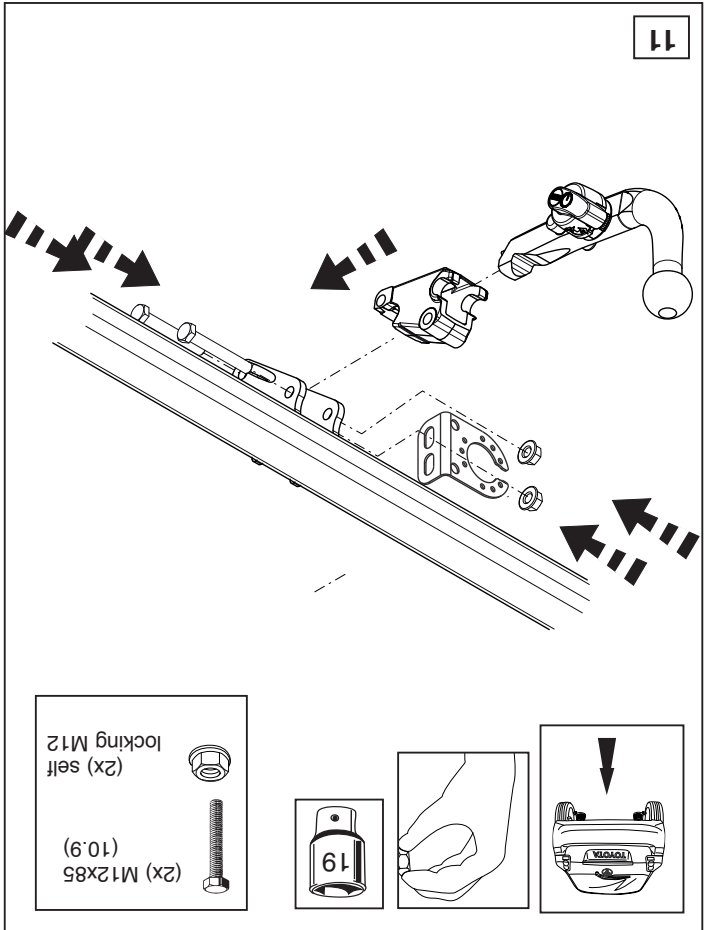
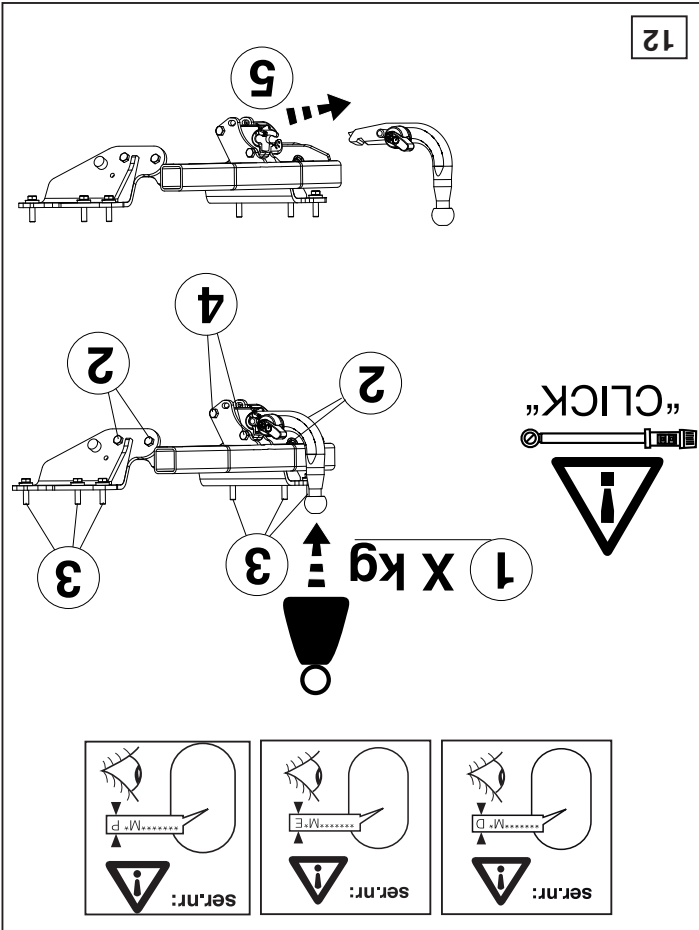
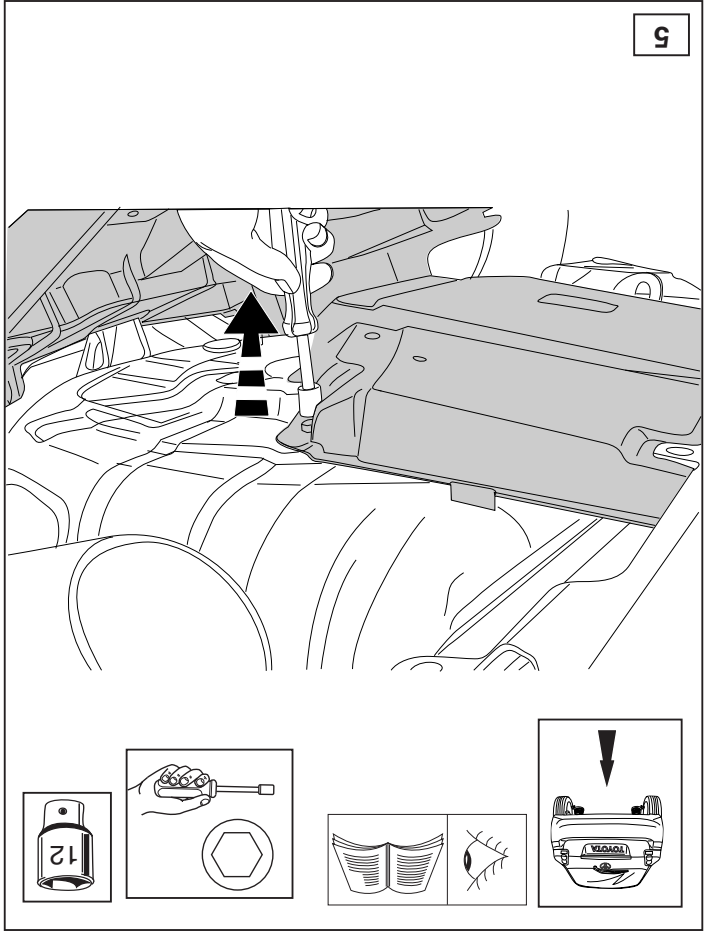
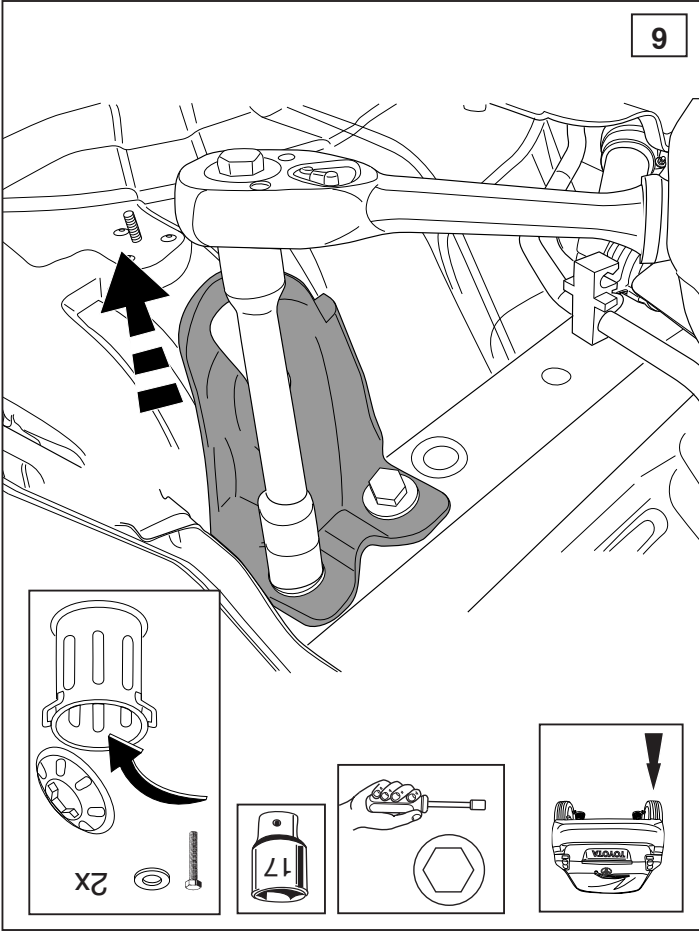

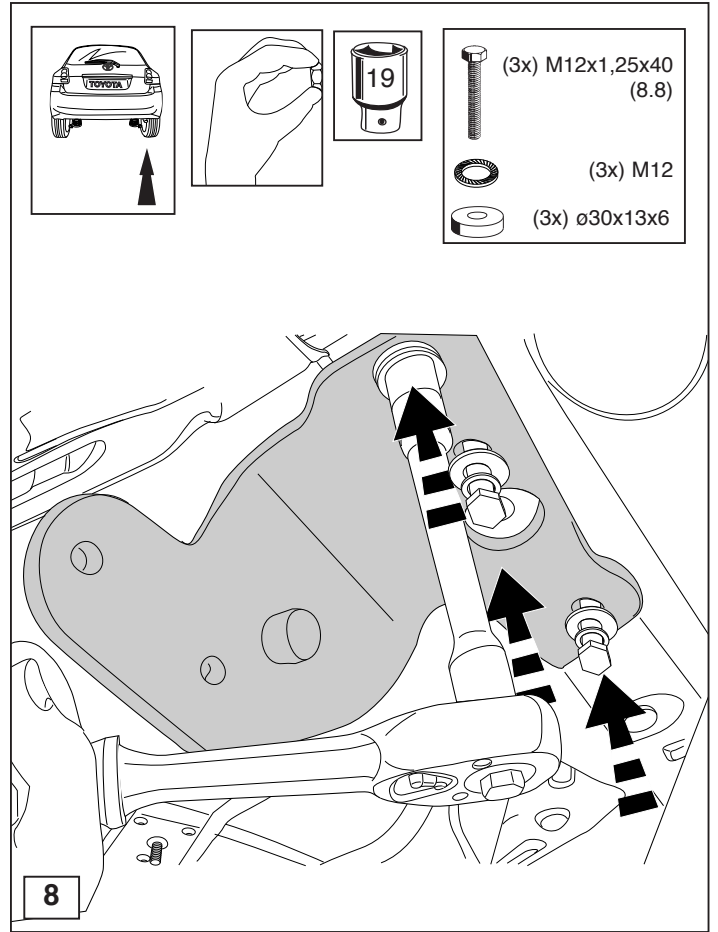
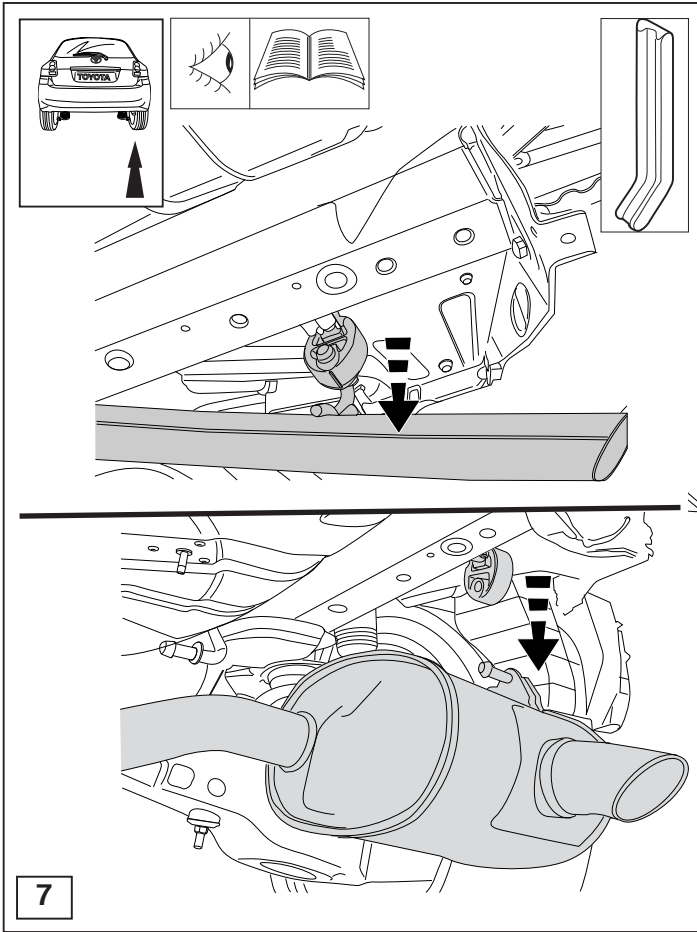

© 529970/12-04-2010/9

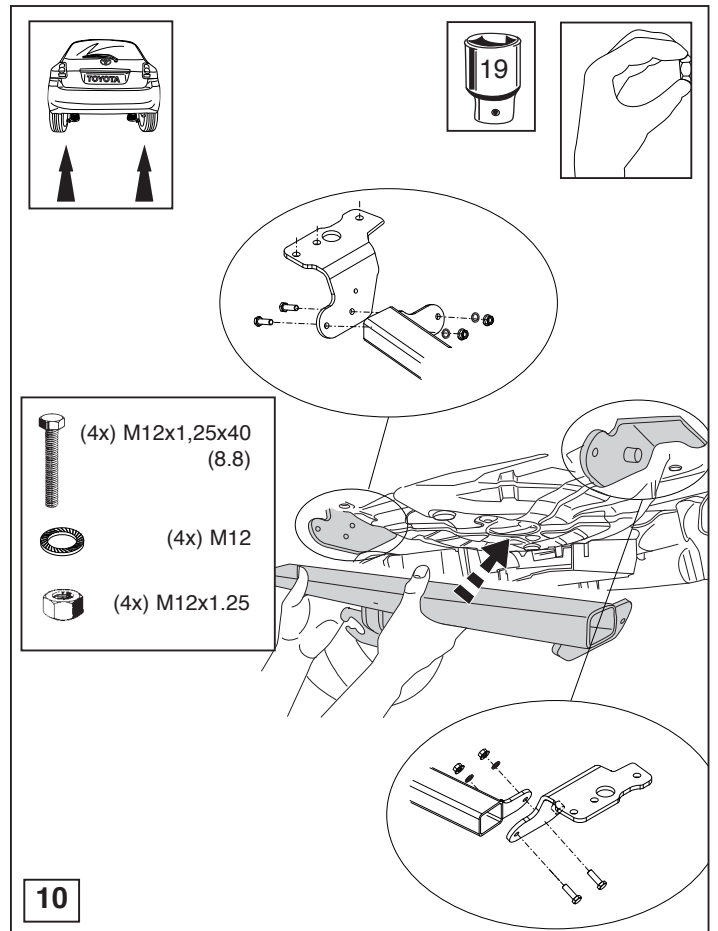
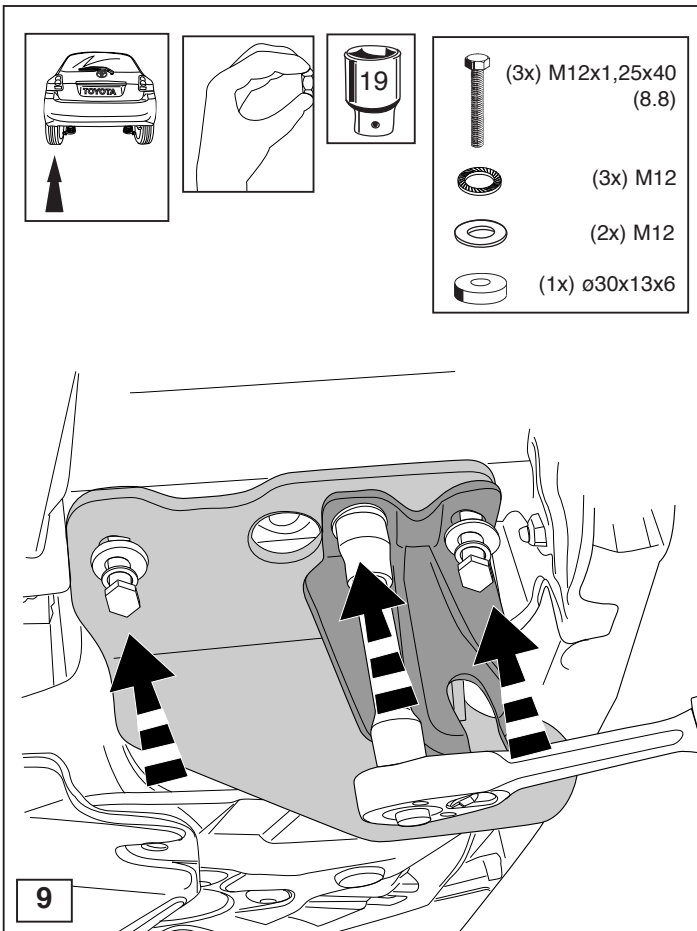

© 529970/12-04-2010/10