

Fitting instructions

Make: Mitsubishi

Pajero / Montero ; 2007->

Type: 4704

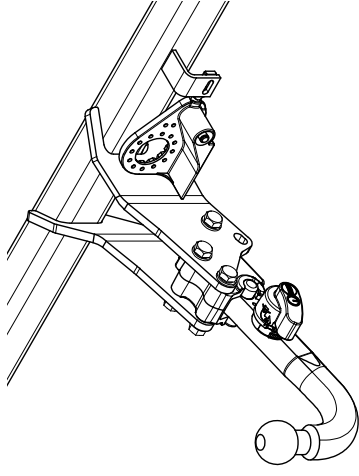

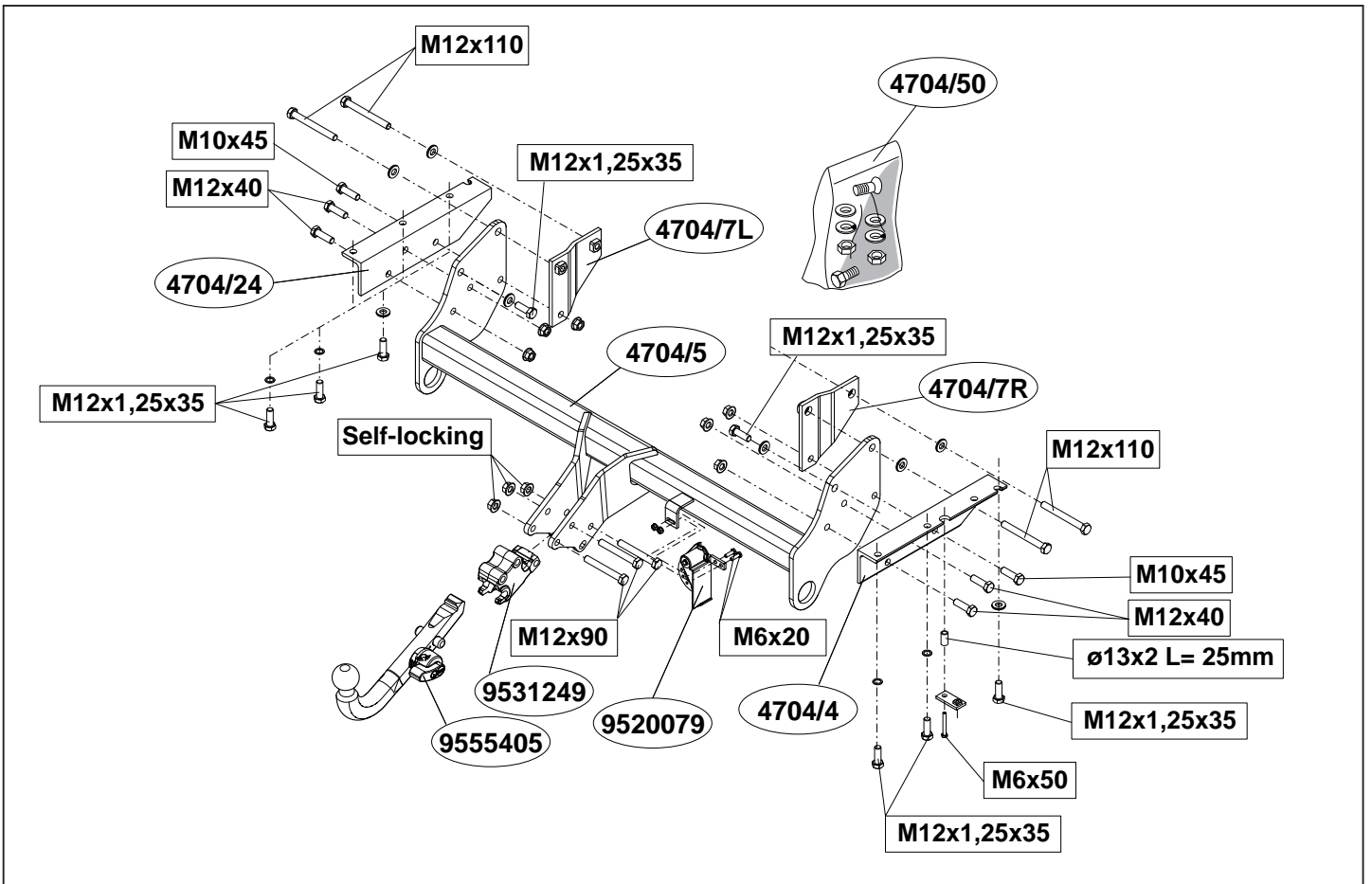

© 470470/20-01-2017/1

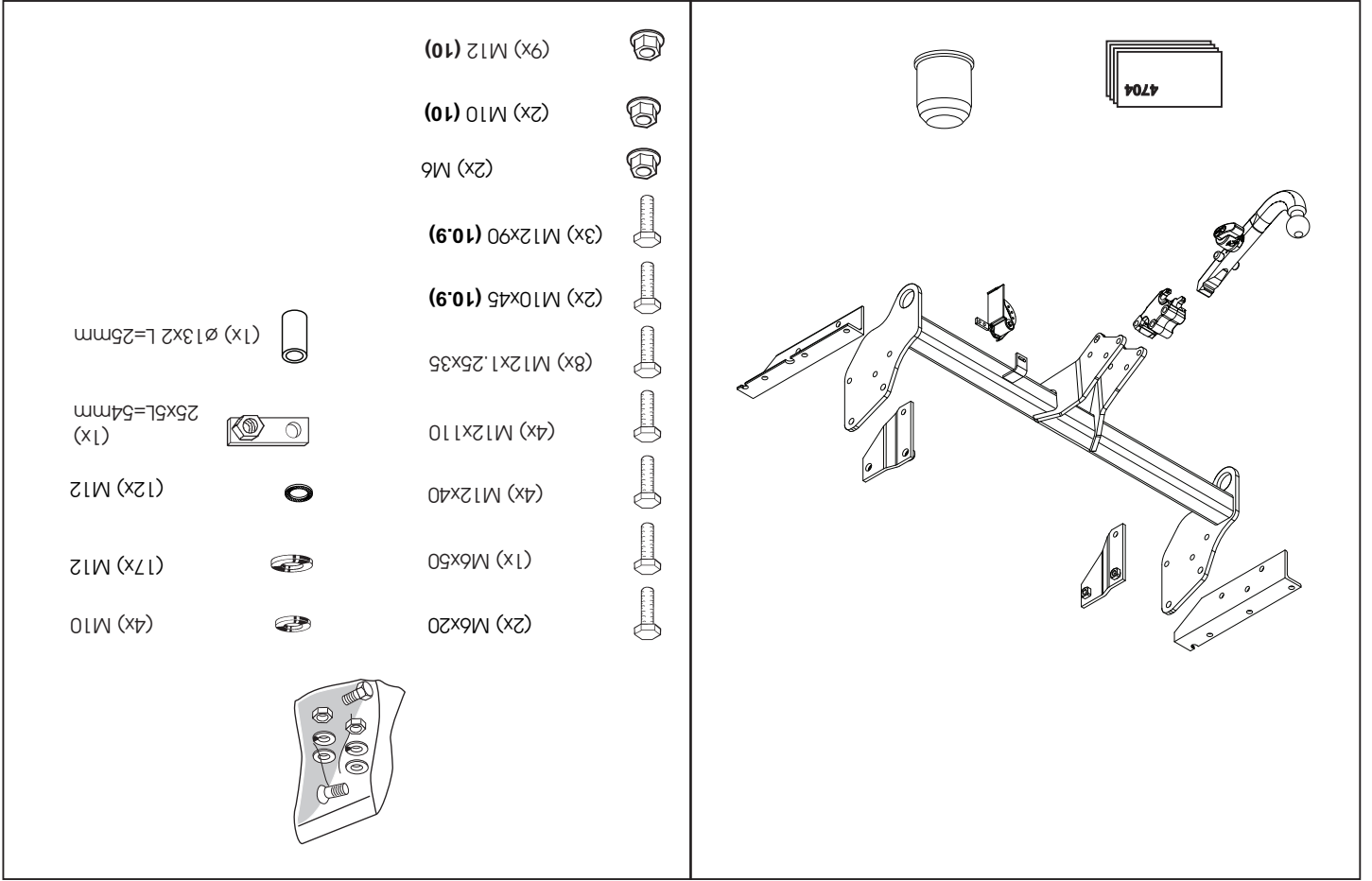

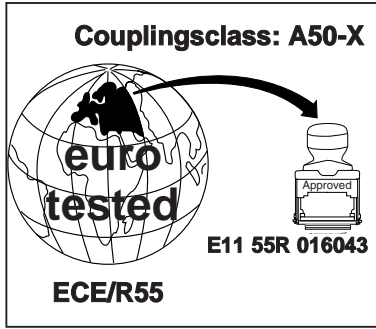
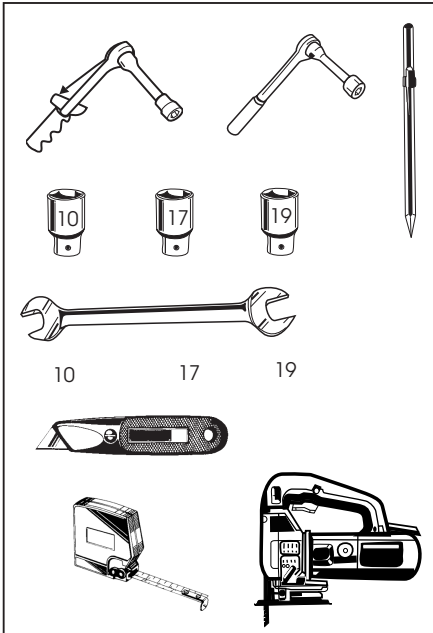

**D-Value : 16,3 kN**

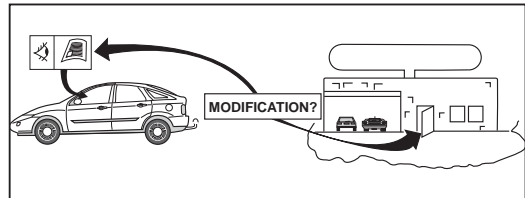
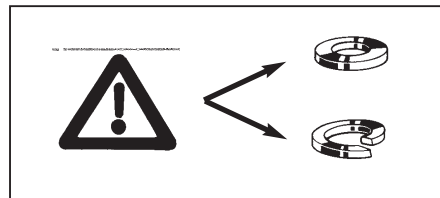
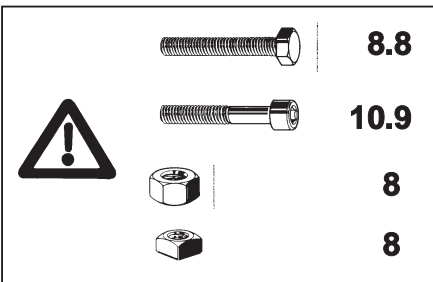
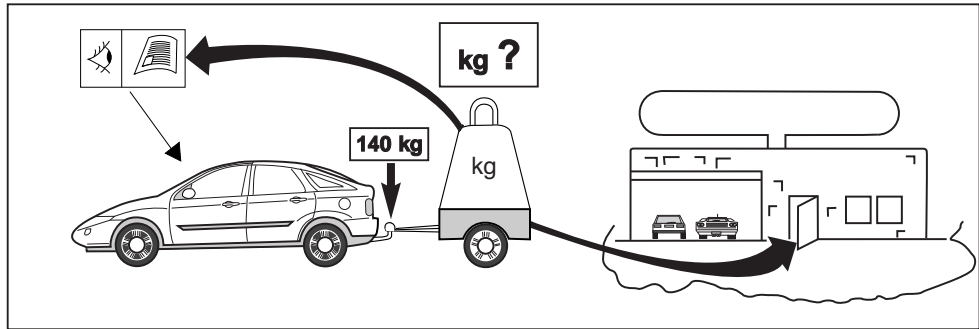

© 470470/20-01-2017/3



Dispositivo di traino tipo: 4704  
 Per autoveicoli: Mitsubishi Pajero / Montero (SWB / LWB); 2007->  
 Tipo funzionale: V80 / V90

Classe e tipo di attacco: A50-X  
 Omologazione: E11 55R 016043  
 Valore D: 16,3 kN  
 Carico Verticale max. S: 140 kg  
 Larghezza rimorchiabile per Caravan e T.A.T.S.: 2,45m vedere CARTA di CIRCOLAZIONE VEICOLO (motrice) + 70 cm = ..arrotondare ai 5 cm superiore (vedi D.M.28/05/85)  
 Massa rimorchiabile: vedi carta di circolazione dell' autoveicolo

**Per verificare l'idoneità del dispositivo di traino omologato a norma CEE 94/20, all'installazione sulla vettura su cui si intende procedere al montaggio, compilare la seguente formula (se necessario declassare la massa rimorchiabile):**

$$D = \frac{T \times C}{T + C} \times 0,00981 \leq 15,8 \text{ kN}$$

dove: T= Massa Complessiva Max. della motrice (in kg)  
 C= Massa Rimorchiabile Max. della motrice (in kg)

**DA COMPILARE PER IL COLLAUDO**

**DICHIARAZIONE DI CORRETTO MONTAGGIO:** la sottoscritta Ditta dichiara di aver montato in maniera corretta ed in conformi/ alle prescrizioni sia del costruttore del veicolo che del costruttore del dispositivo stesso il seguente dispositivo di attacco meccanico:

tipo:.....  
 Il dispositivo di attacco sopra indicato è stato installato su autoveicolo  
 modello:.....  
 targa:.....  
 Data:.....

**TIMBRO e FIRMA**

**Si dichiara inoltre di aver informato l'utente del veicolo sull'USO e MANUTENZIONE del dispositivo stesso.**



**\* Should this installation process entail the cutting of the bumper – conformation MUST be obtained by the installation engineer of the customer's acceptance prior to completion. Brink International do not accept responsibility for any matters arising as a result of this miscommunication.**

**NOTE:**

\* Die für das Fahrzeug zugelassene Anhängelast ist den Fahrzeug Unterlagen zu entnehmen. Bei Änderungen des Fahrzeuggewichtes muß die höchstzulässige Anhängelast gegebenenfalls aus dem D-Wert nachgerechnet werden.  
Auskunft hierüber kann Ihr Fachhändler oder der TÜV geben.  
\* Elektrische Anlage gemäß SIVZO anbringen.

**HINWEISE:**

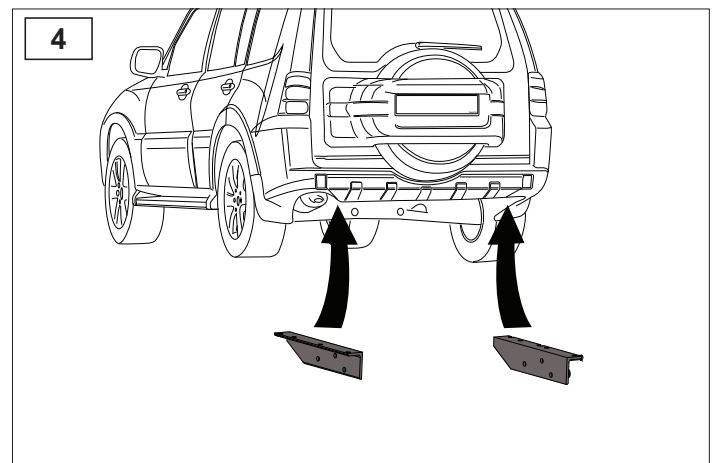
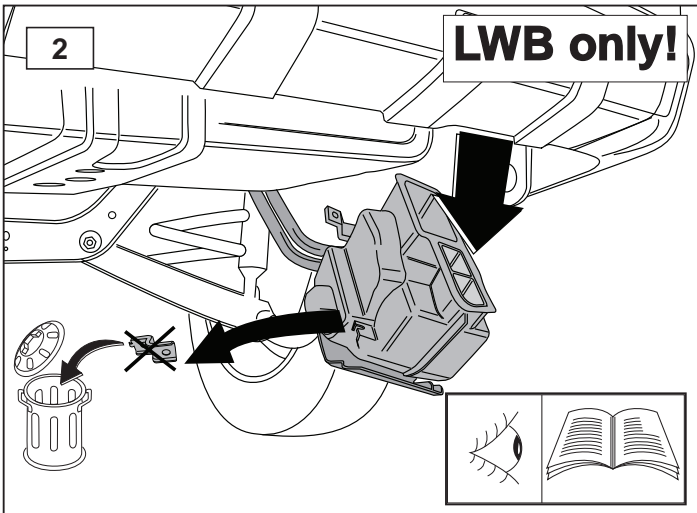
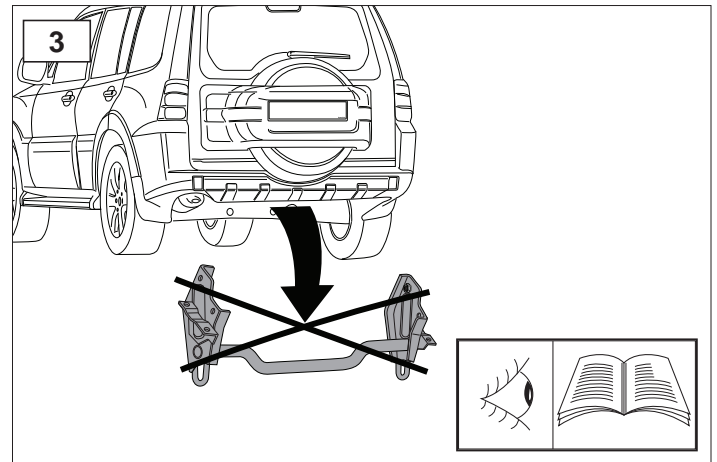
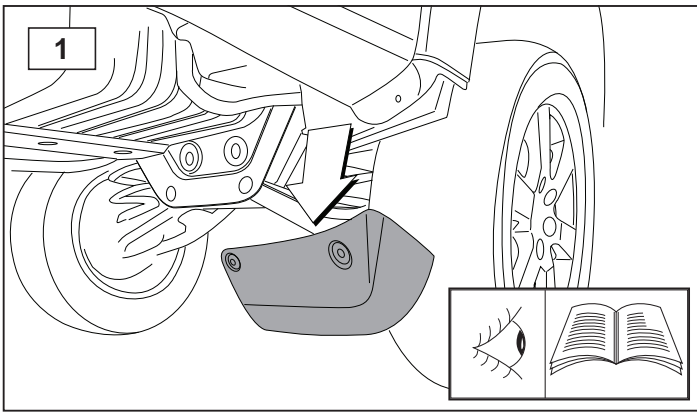

© 470470/20-01-2017/5

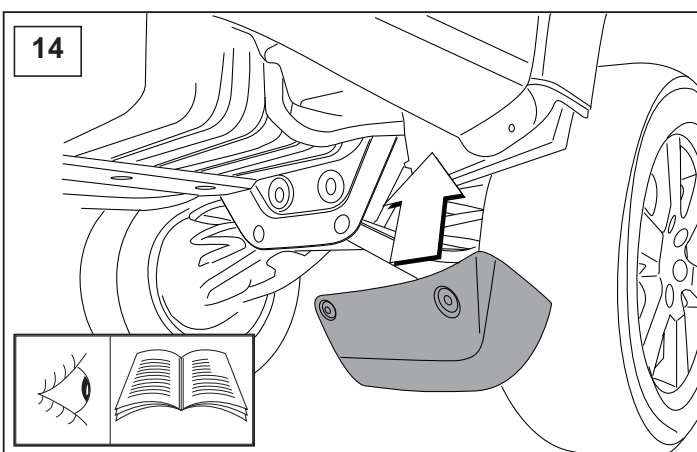
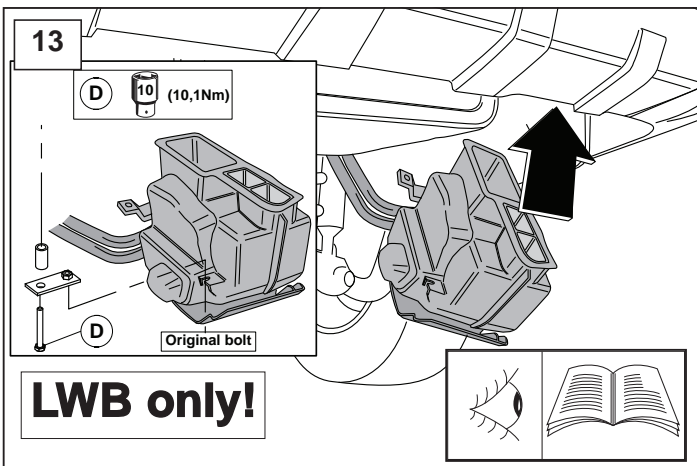

© 470470/20-01-2017/10

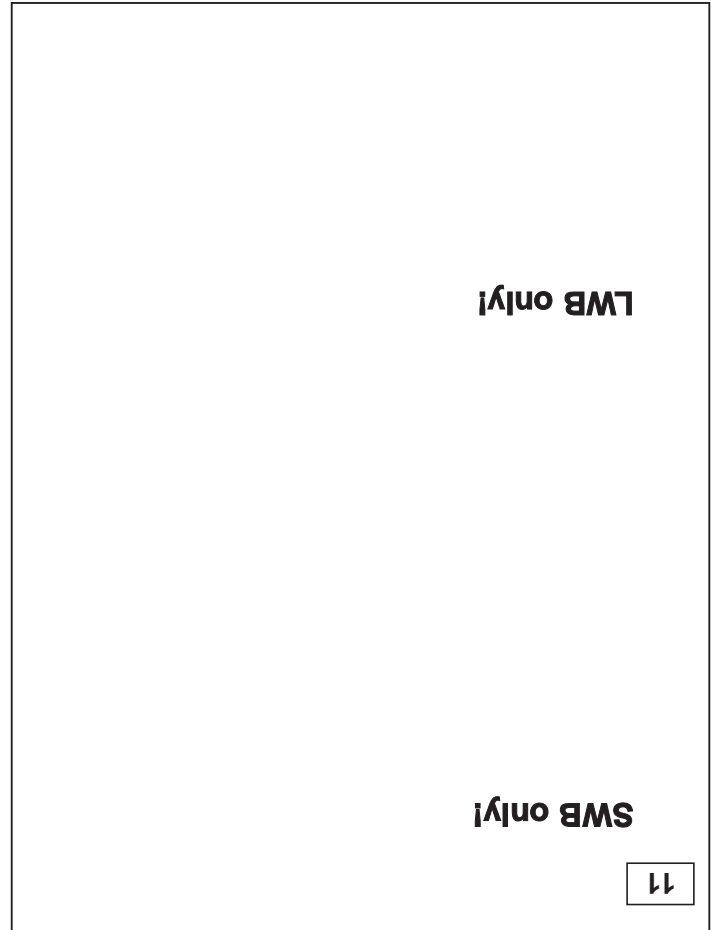
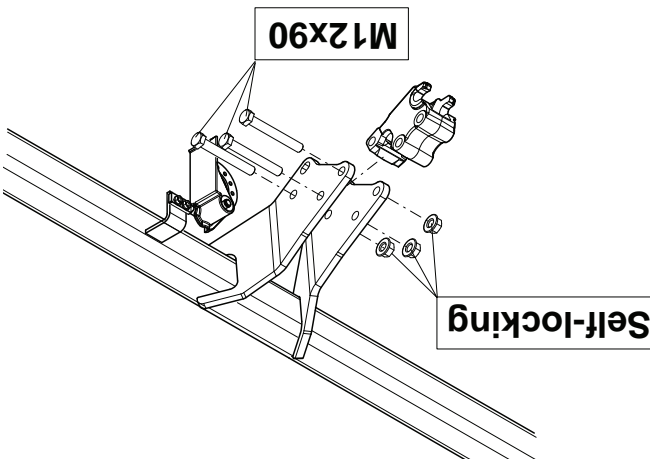
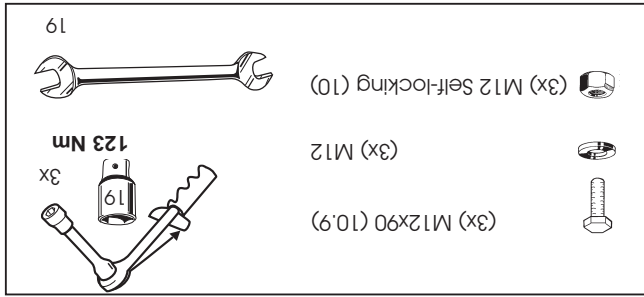
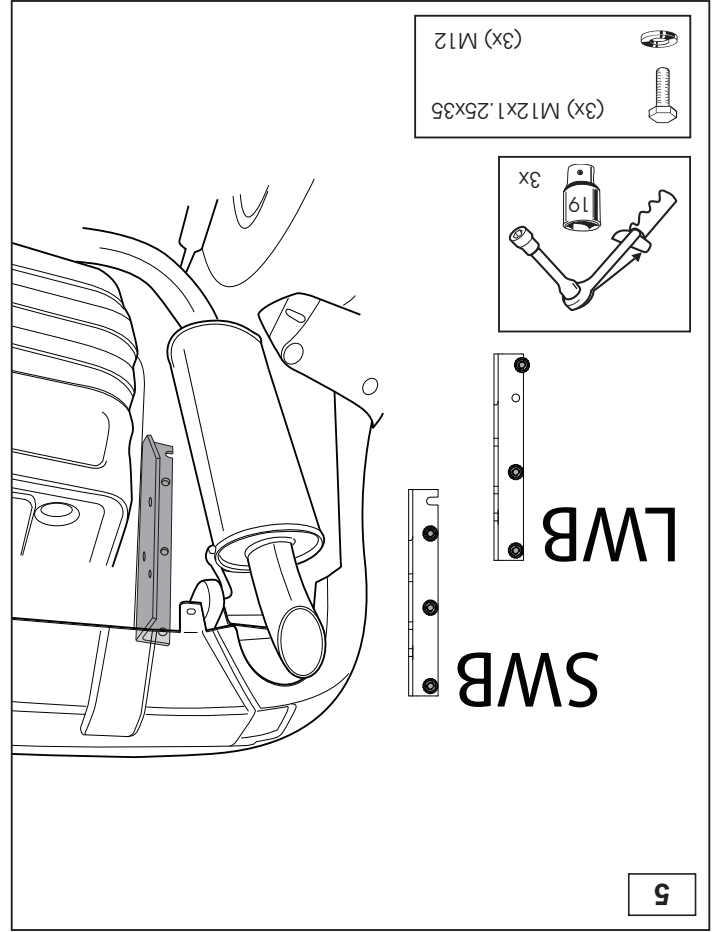
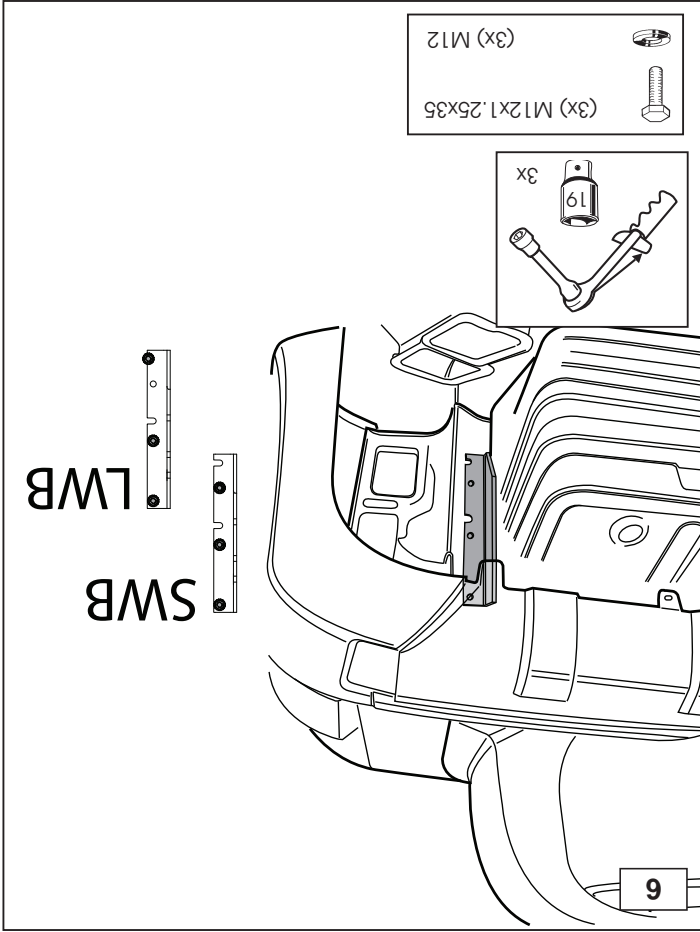

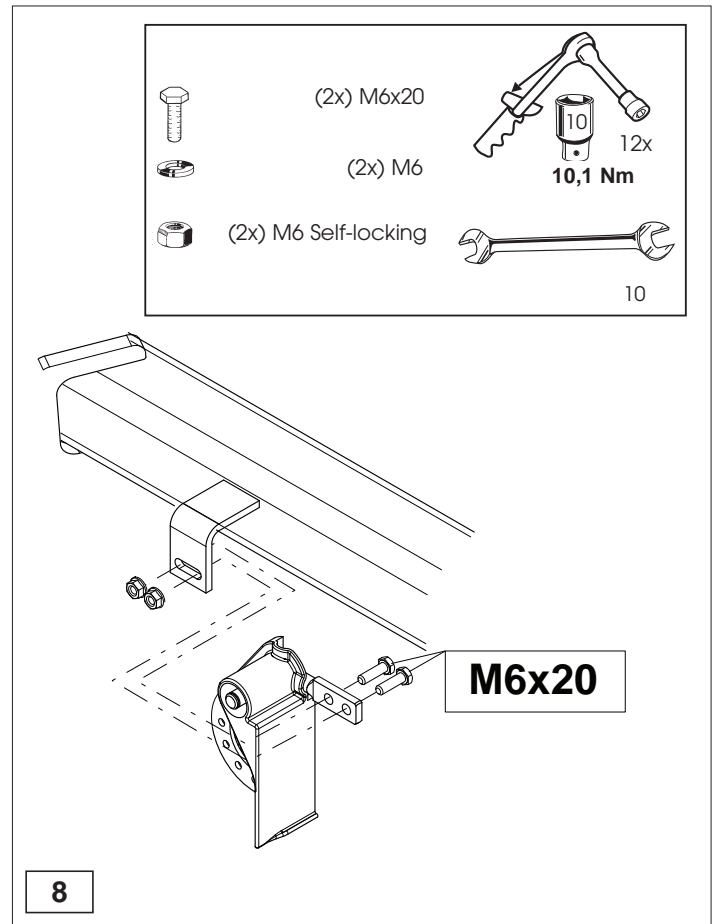
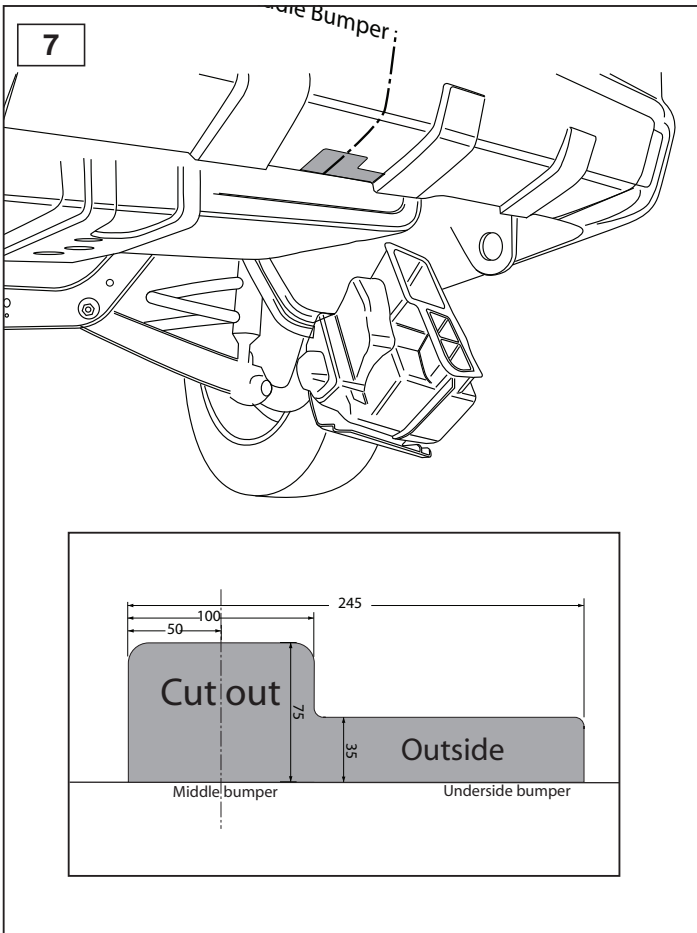

© 470470/20-01-2017/7

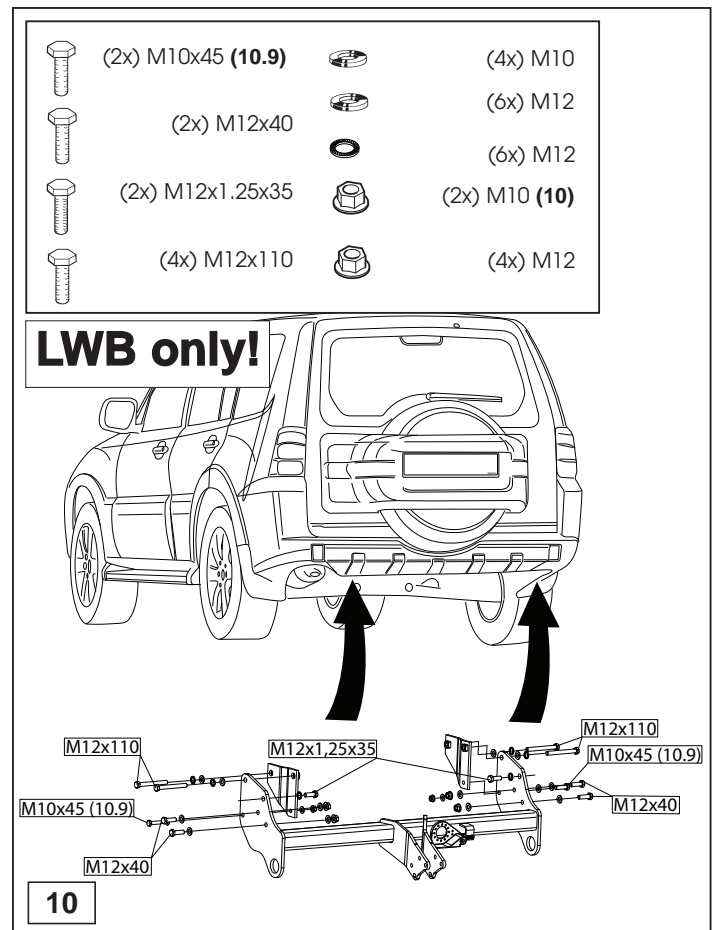
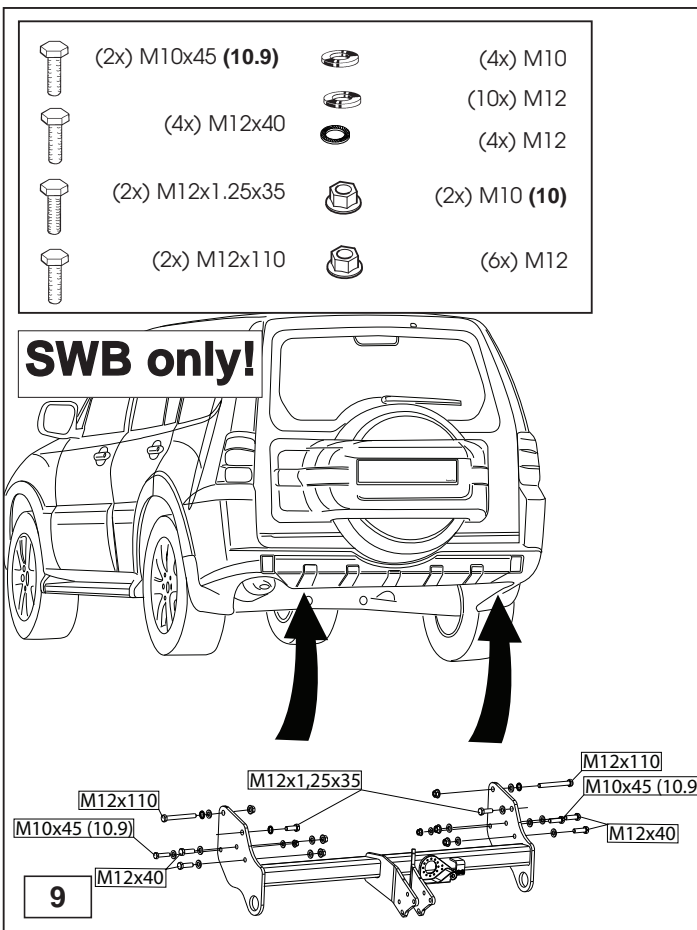

© 470470/20-01-2017/8