

Fitting instructions

Make: Mitsubishi

Colt; 2006->

Type: 4084

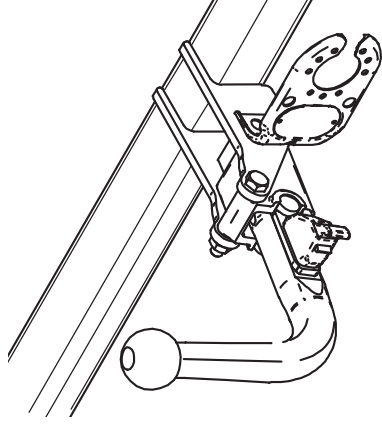

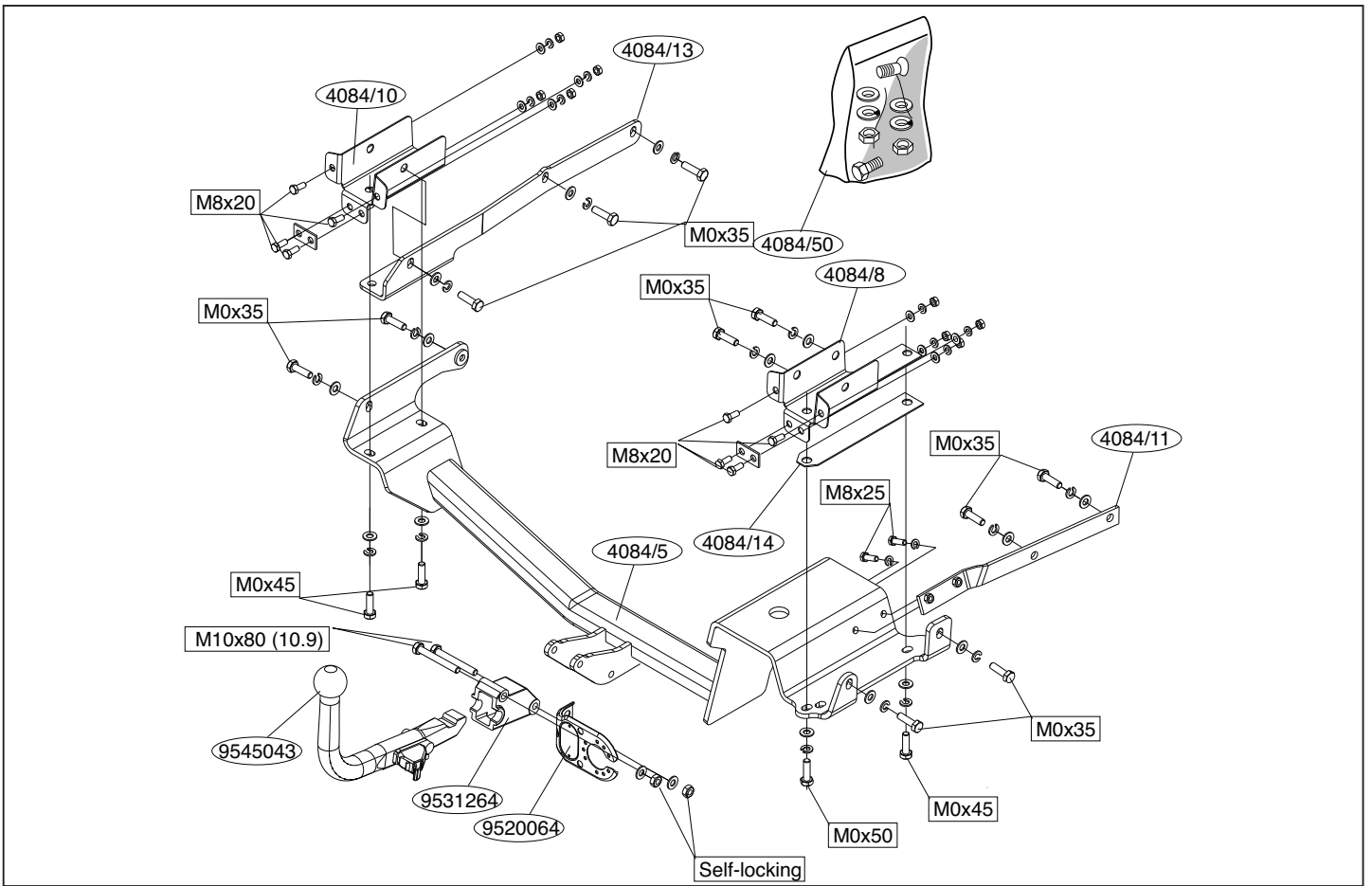

© 408470/16/03/09/1

© 408470/16/03/09/14

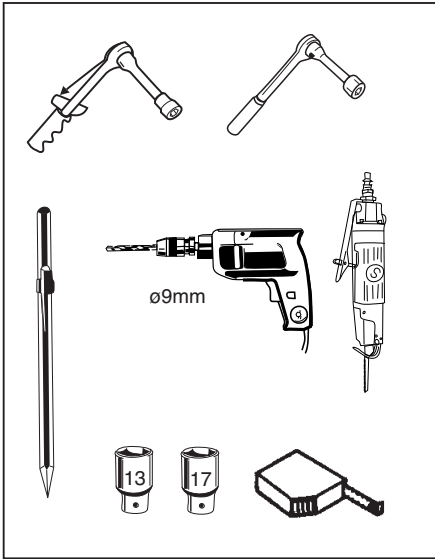

Couplingsclass: A50-X

euro tested

Approved

e11 00-5113

94/20/EC

D-Value : 5,0 kN

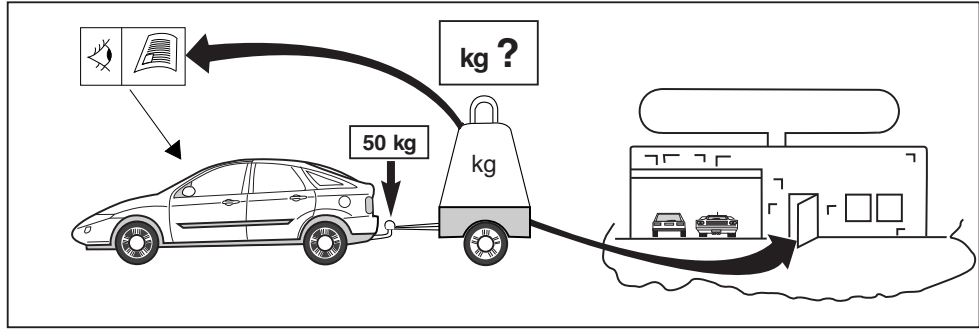

8.8

10.9

8

10

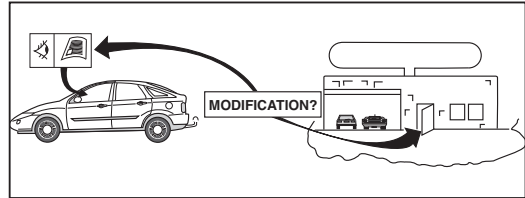
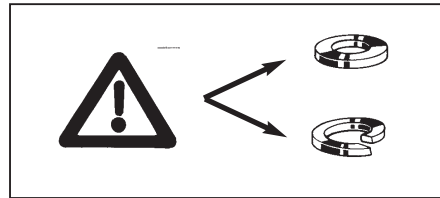

© 408470/16/03/09/3

M10x80

Self-locking (10)

15

60 Nm

2x

M10

(2x) M10x80 (10.9)

(2x) M10

M10 (self-locking)

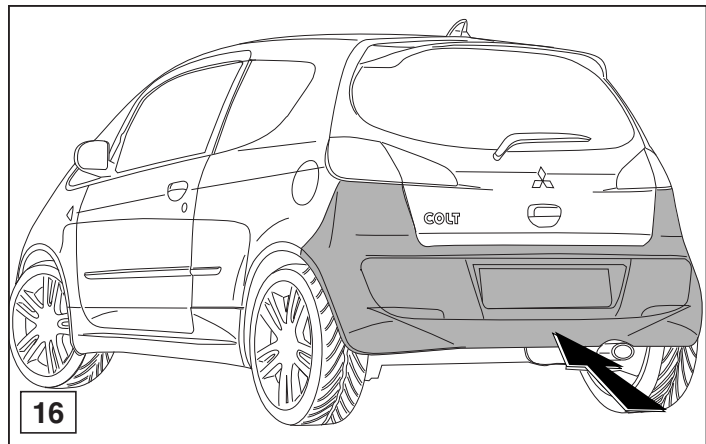

© 408470/16/03/09/12

HINWEISE:

- * Die für das Fahrzeug zugelassene Anhängelast ist den Fahrzeug Unterlagen zu entnehmen. Bei Änderungen des Fahrzeuggewichtes muß die höchstzulässige Anhängelast gegebenenfalls aus dem D-Wert nachgerechnet werden.
- * Auskunft hierüber kann ihr Fachhändler oder der TÜV geben.
- * Elektrische Anlage gemäß StVZO anbringen.

NOTE:

- * Should this installation process entail the cutting of the bumper – confirmation MUST be obtained by the installation engineer of the customer's acceptance prior to completion. Brink International do not accept responsibility for any matters arising as a result of this miscommunication.

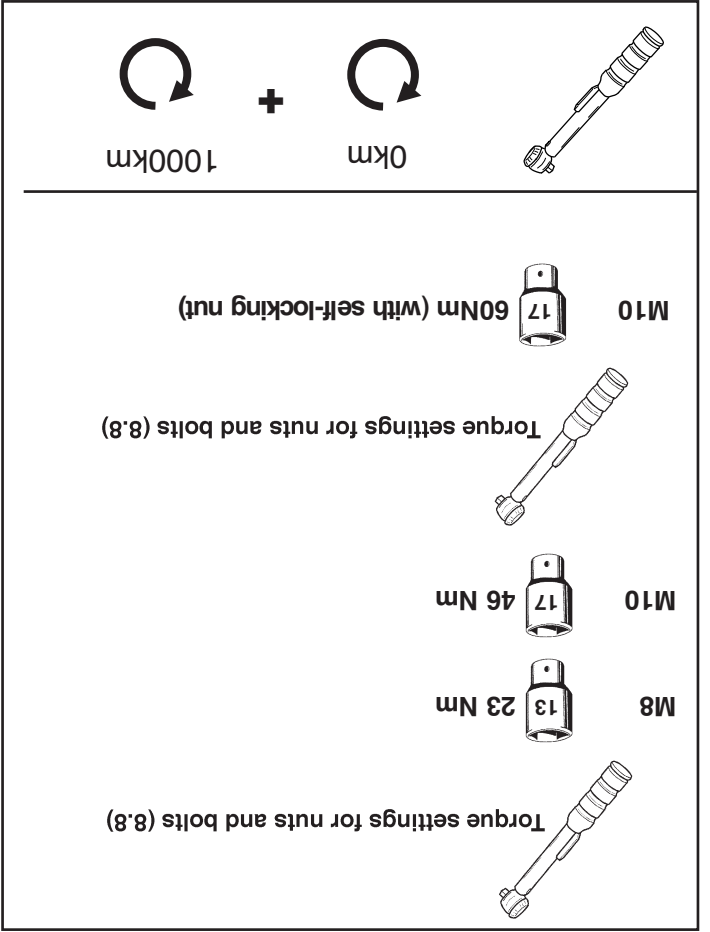
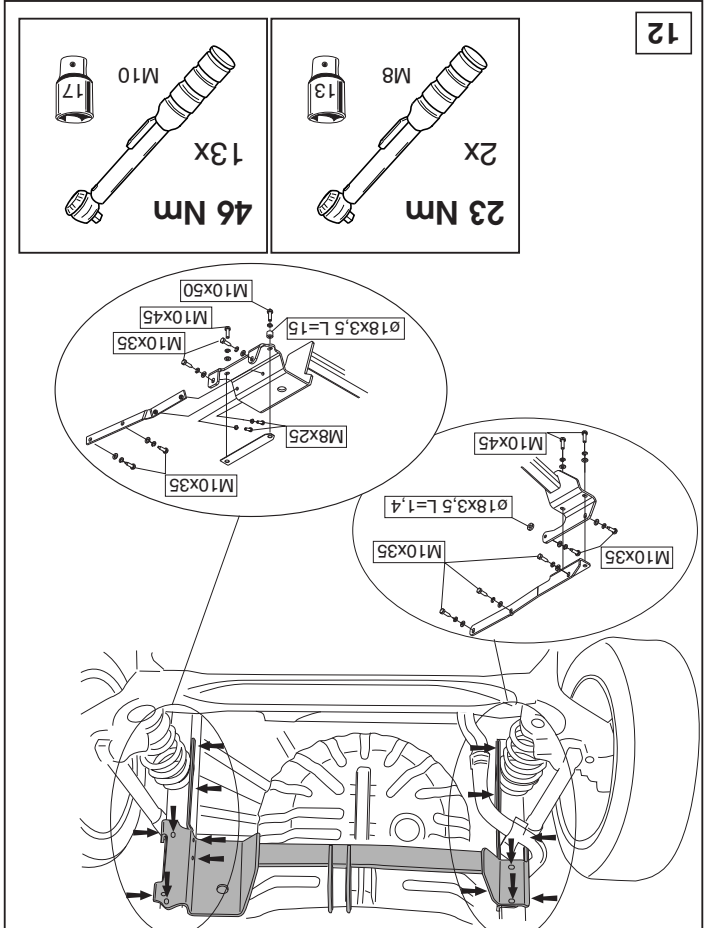
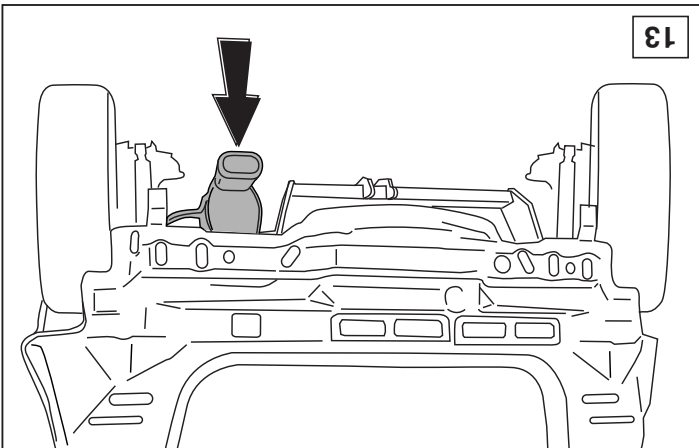
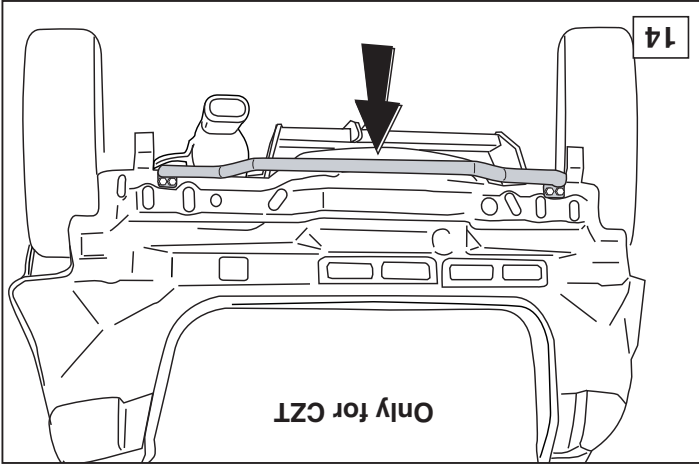

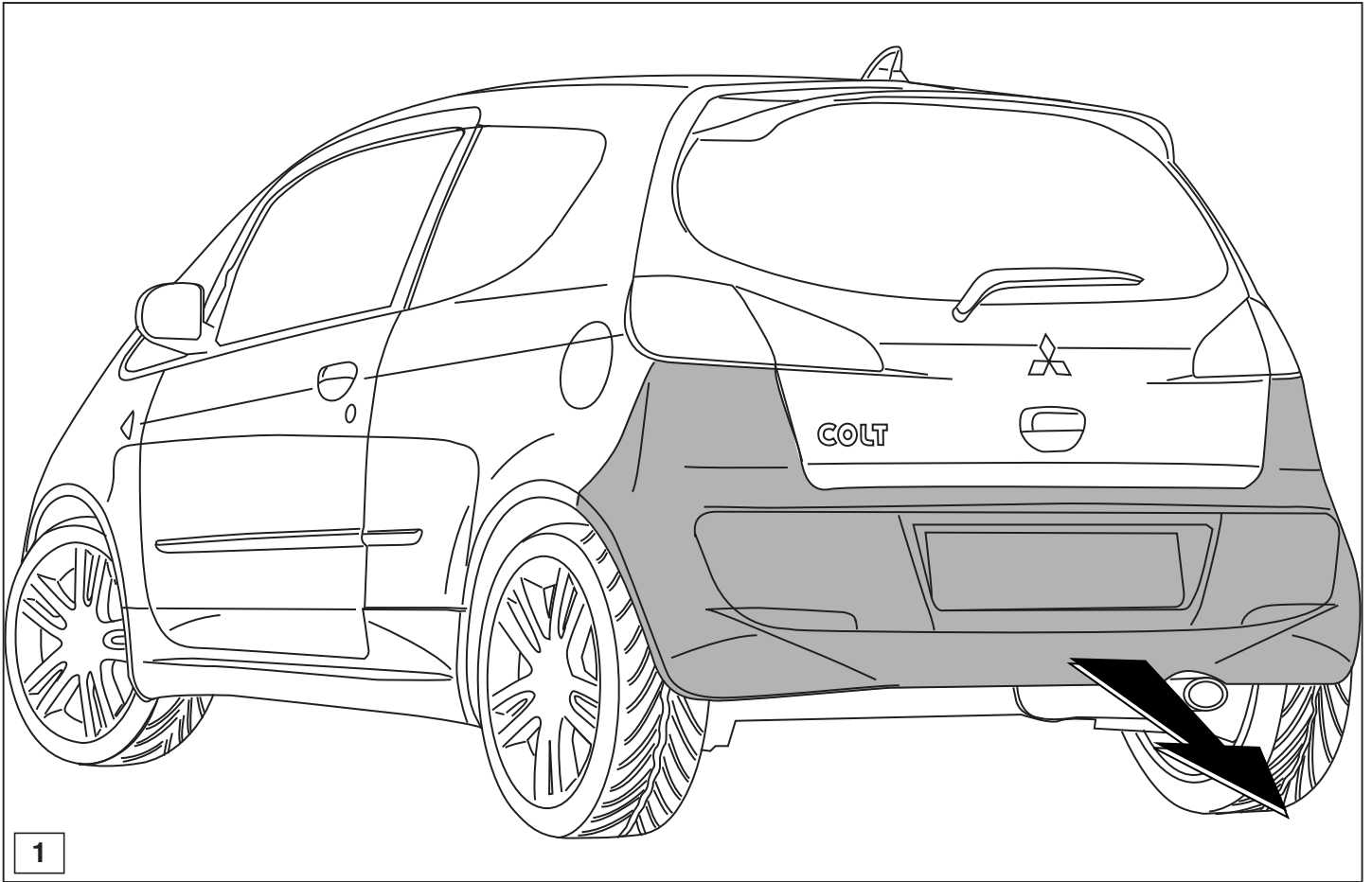

1

© 408470/16/03/09/5

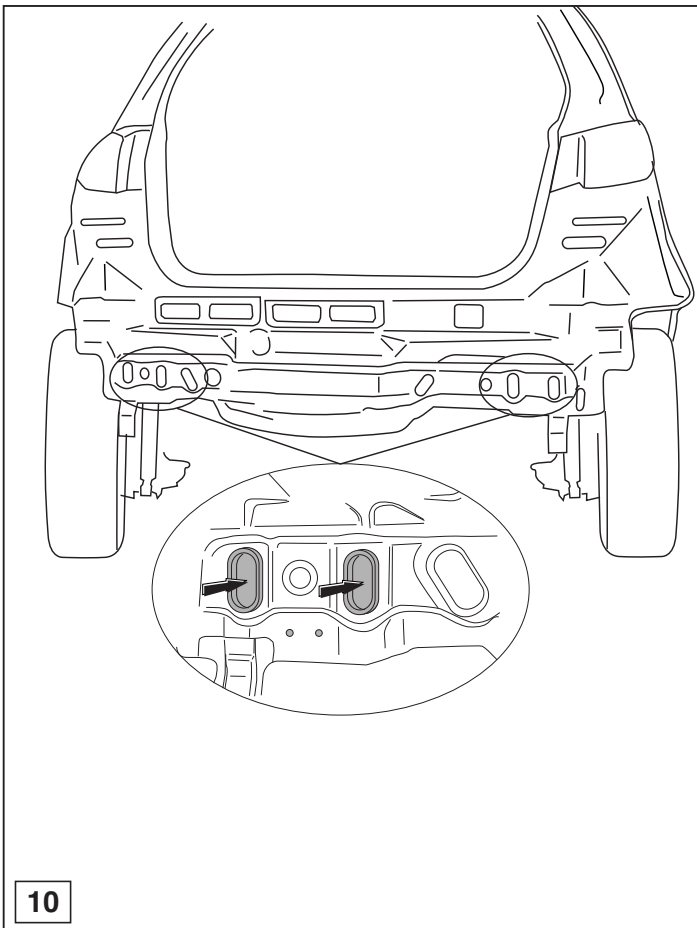

10

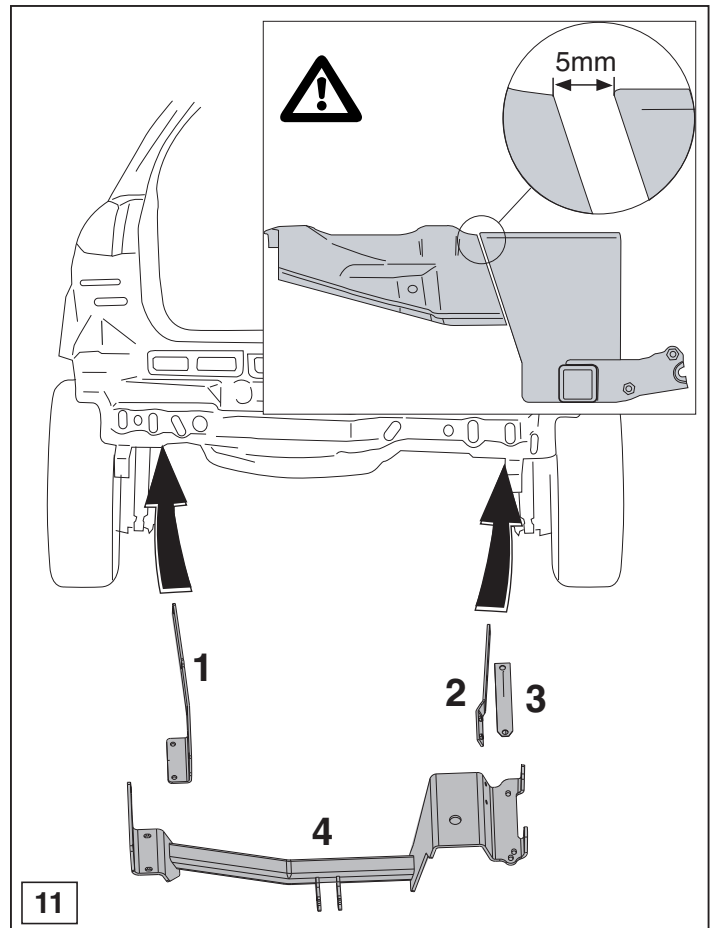

11

© 408470/16/03/09/10

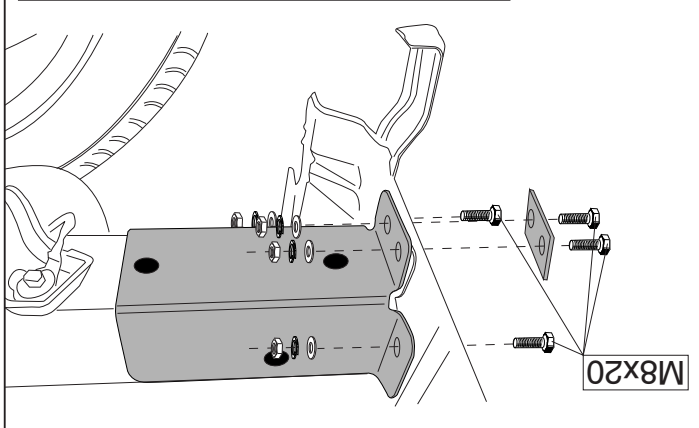
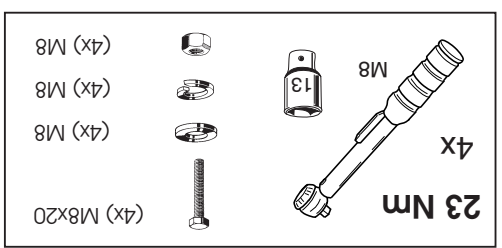
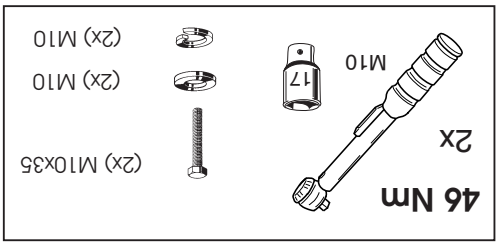
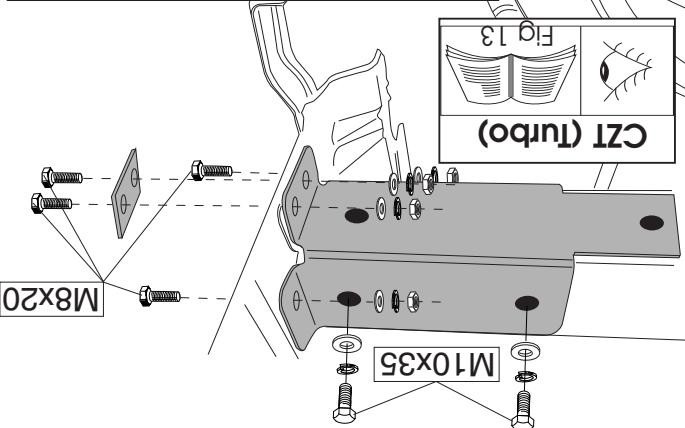
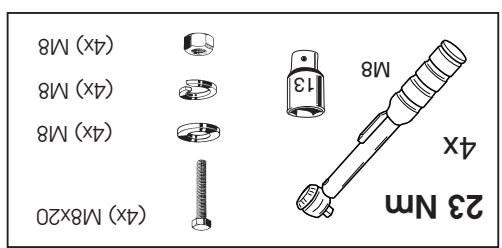
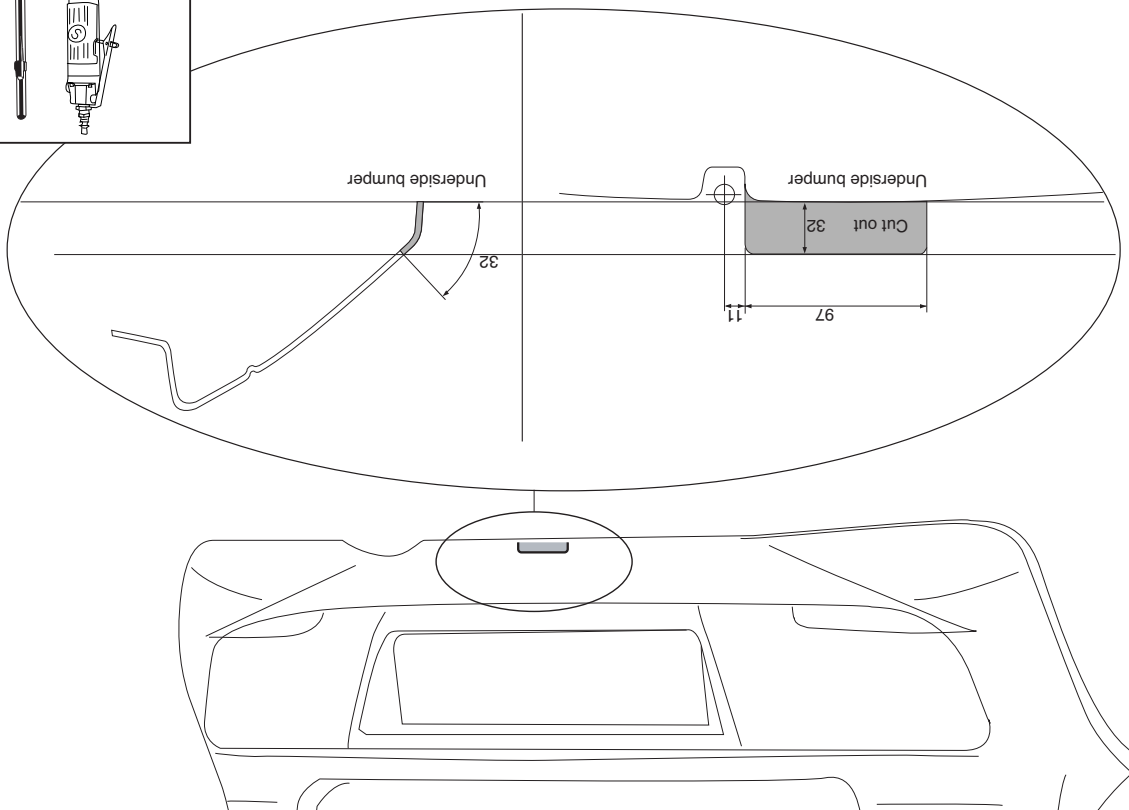
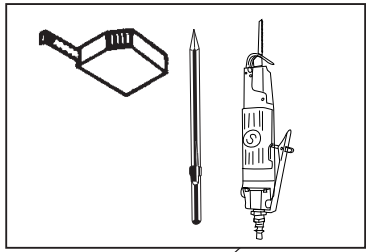

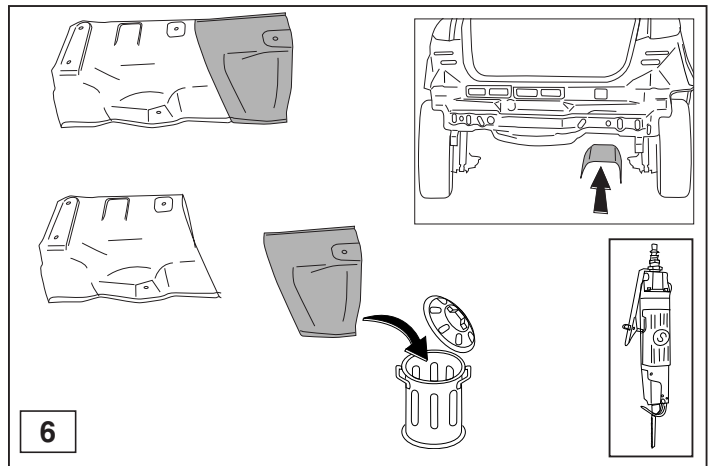
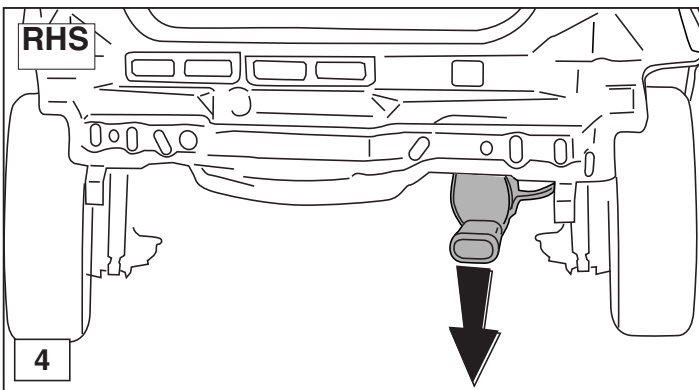
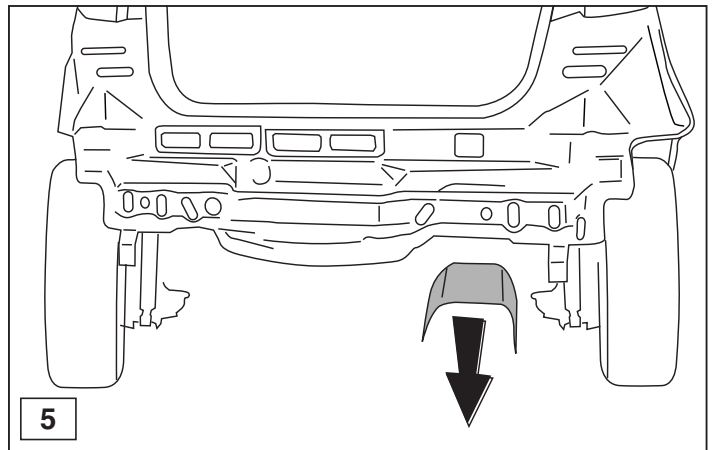
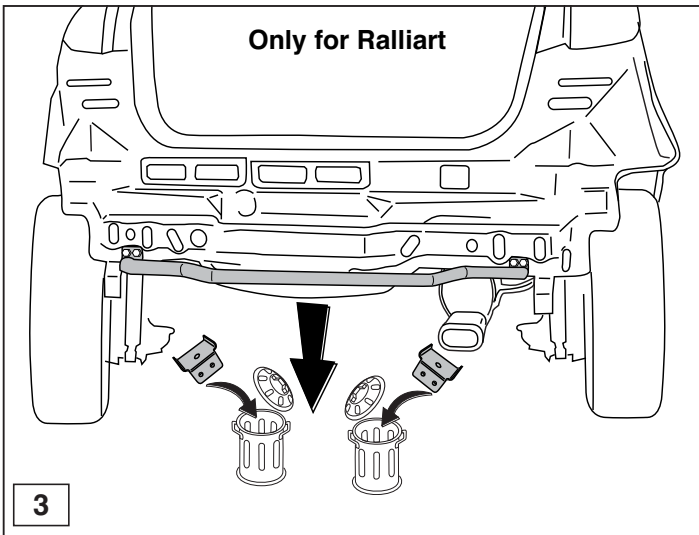

© 408470/16/03/09/7

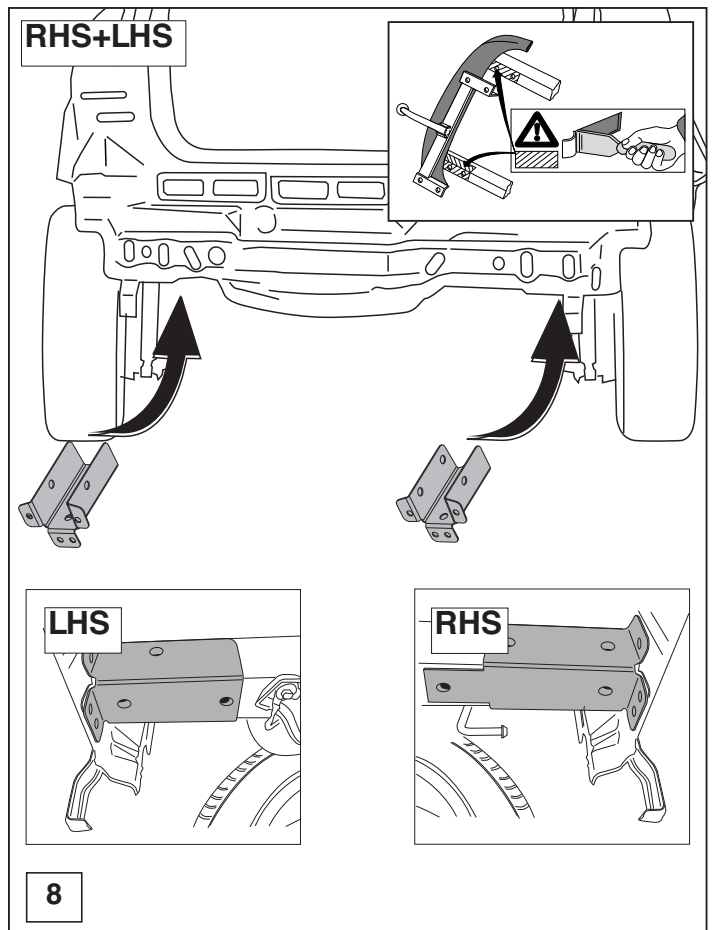
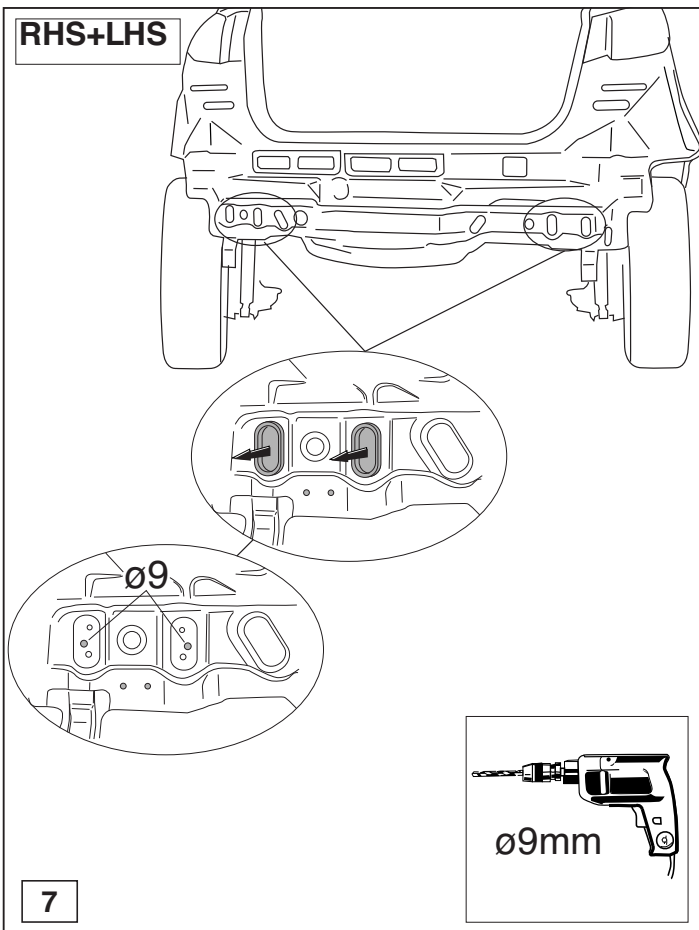

© 408470/16/03/09/8