

Fahrzeuge **bis**
Chassis-Nummer:
JSAJTD44V00272097
JSAJTD54V00263188

MVG: 3515-A

Suzuki Grand Vitara 5 Tüerer (JT) 2006->

(E) Instrucciones de montaje

(D) Einbauanleitung

(GB) Installation instruction

(F) Notice de montage

(NL) Inbouw-instructie

(S) Monteringsanvisning

(CZ) Návod k montáži

(I) Istruzioni di montaggio

An der Wasserwiese 1
D-52249 Eschweiler

E-mail: info@mvg-ahk.de
Internet: www.mvg-ahk.de

Tel.: (02403)7902-61
Fax: (02403)7902-33

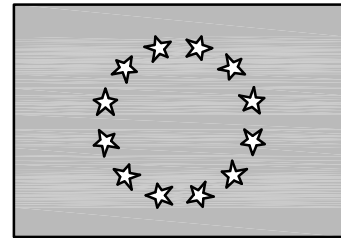
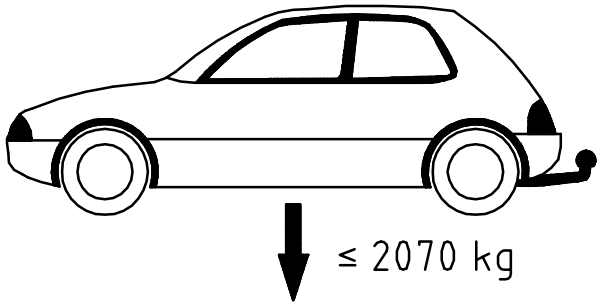

EG

e4 * 2001/116*0091

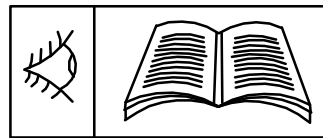

$$D = 10,5 \text{ kN}$$

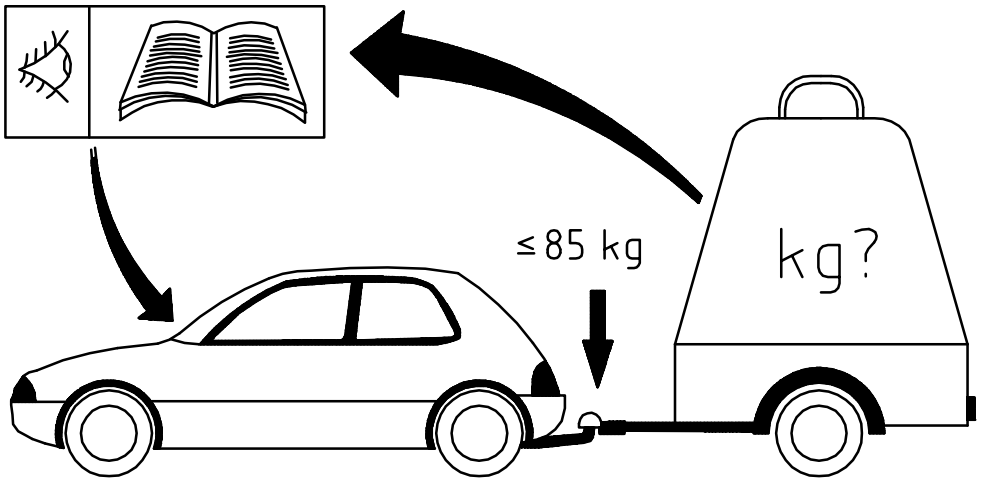

$$g = 9,81 \text{ m/s}^2$$

$$D = \frac{T \times R}{1000 \times (T+R)} \times g$$

$$T = \frac{R \times D \times 1000}{g \times R - 1000 \times D} \times g$$

$$R = \frac{T \times D \times 1000}{g \times T - 1000 \times D}$$

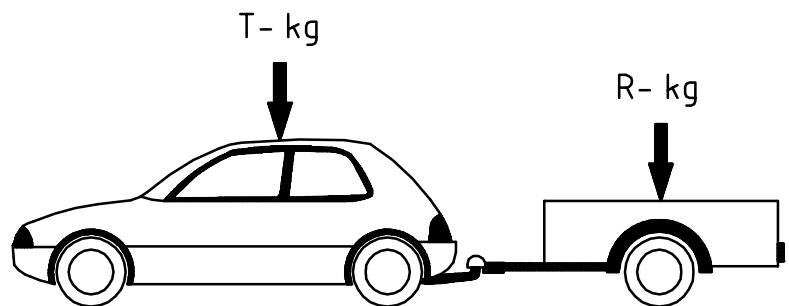

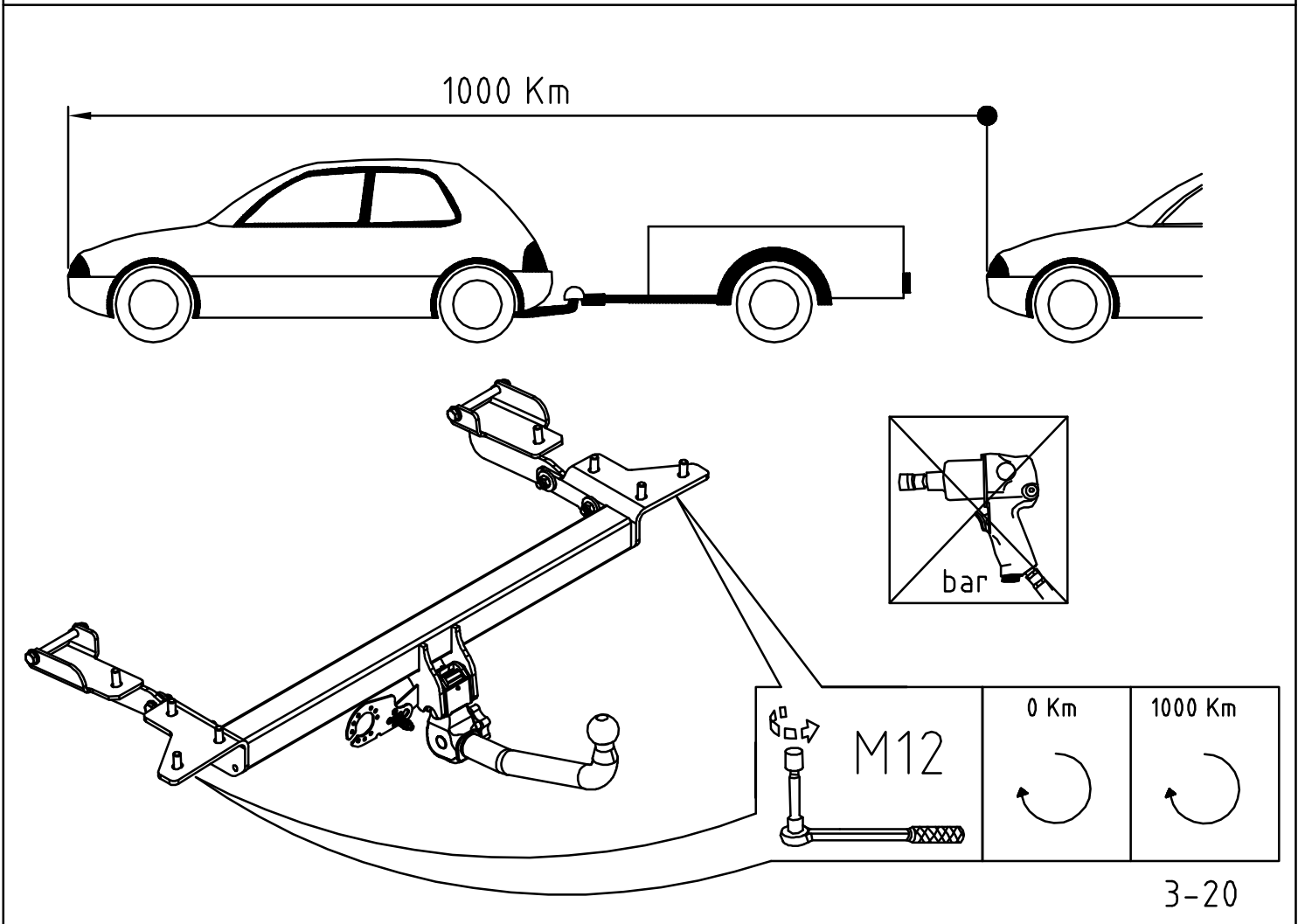
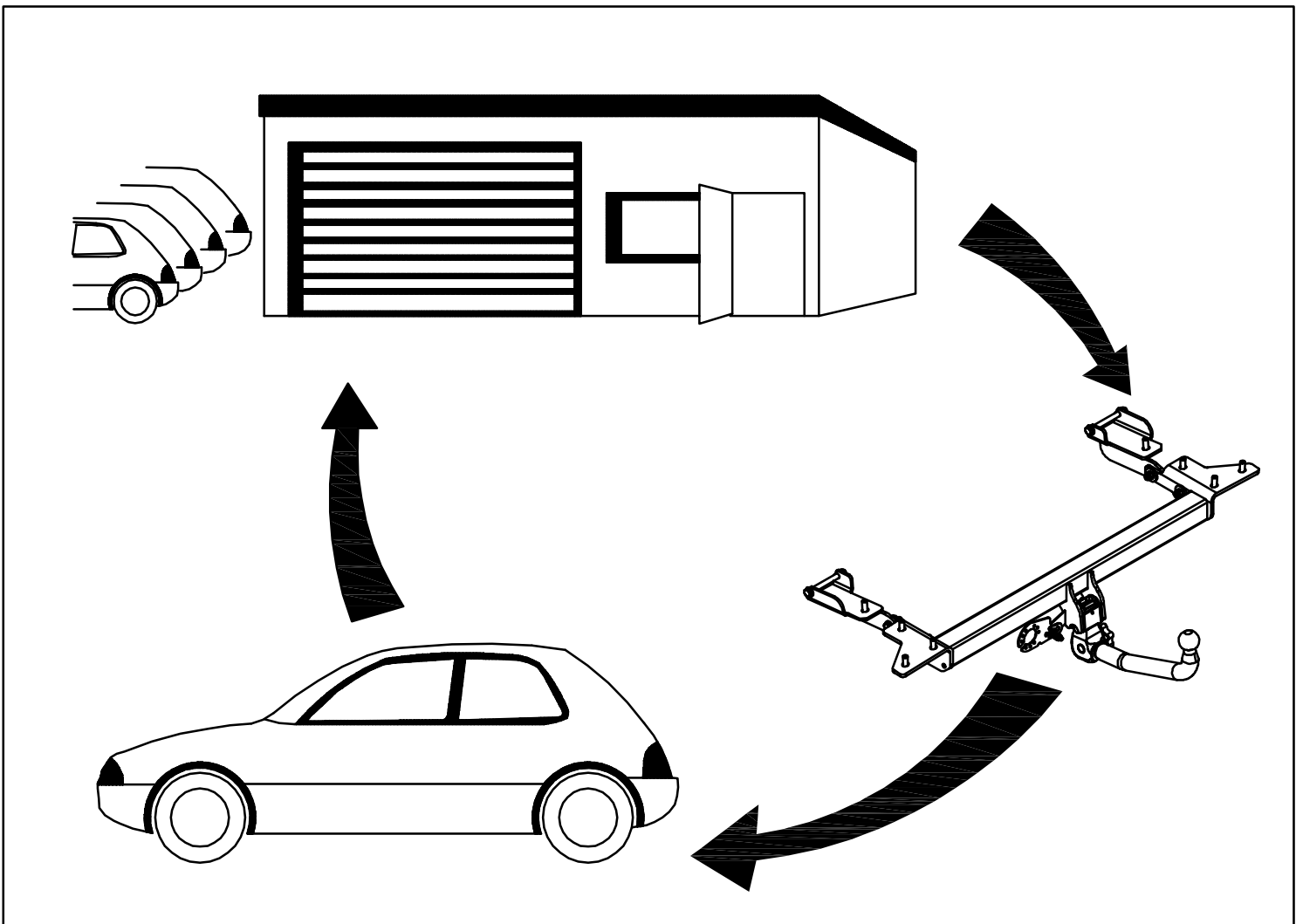

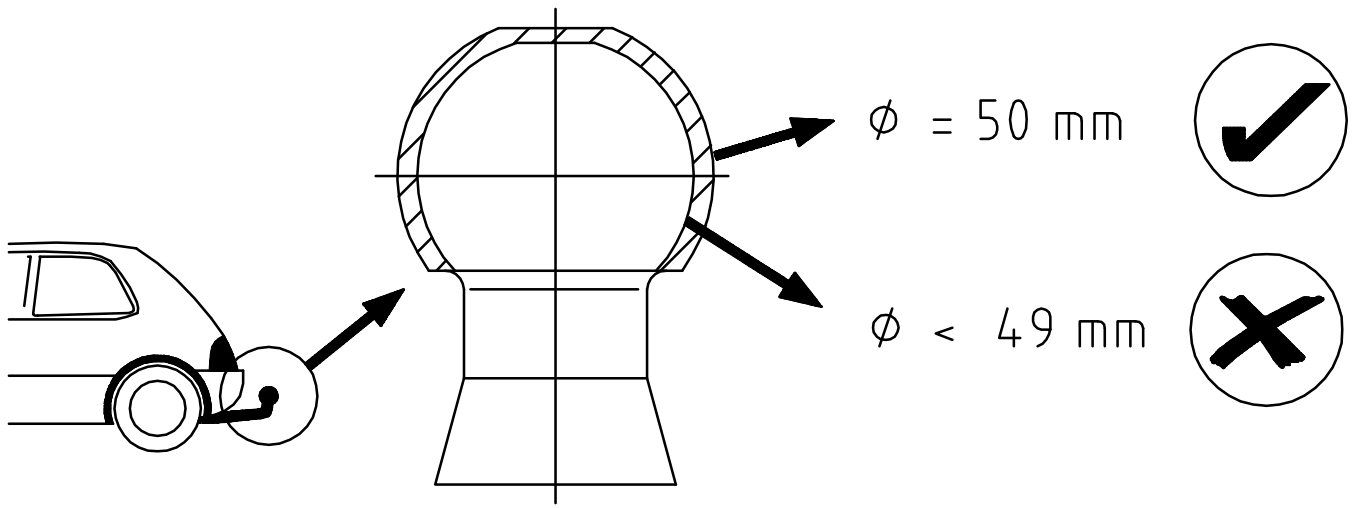

MVG 277
FAHRZEUGE FÜR DEN HILFENANWAND

Approval Number
 e4 00- 3412

Type: 3515 A D-Value: 10,5kN









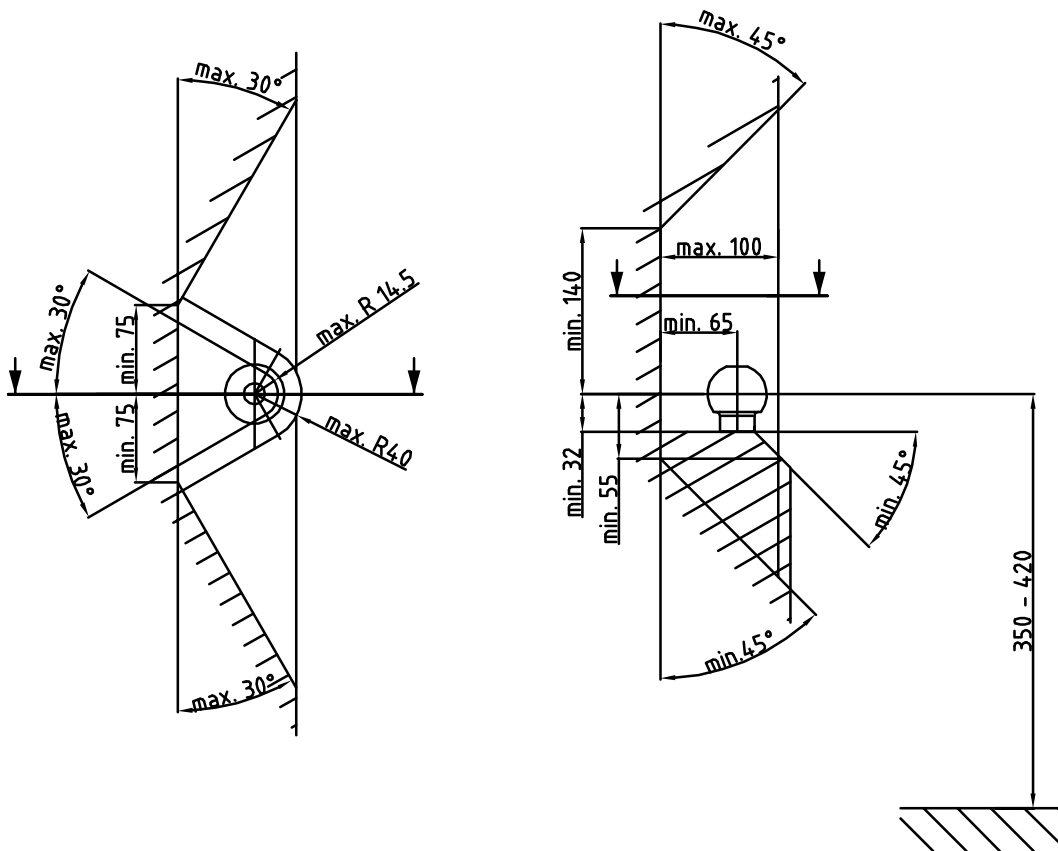

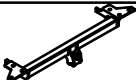













Class: A50-X S-Value: 100kg



Made in Germany www.mvg-ahk.de

Zulässige Stützlast
 maximal 85kg

MVG
FAHRZEUGE FÜR DEN HILFENANWAND
 www.mvg-ahk.de

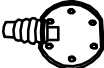

1	1x		3515-A
2	1x		2020-A-25.1
3	1x		links
4	1x		rechts
5	2x		M12x120 (8.8) DIN 931
6	8x		M12x1,25x40 (8.8) DIN 961
7	4x		M12x40 (8.8) DIN 933
8	8x		A12 Fst. DIN 127
9	12x		∅ 13/35x5 DIN 6340
10	2x		∅ 12,5/30x1,5
11	8x		∅ 13/24x2,5 DIN 125
12	6x		M12 (8) DIN980V
13	1x		
14	1x		M8x45 (8.8) DIN 933
15	1x		
16	1x		∅ 8,4/16x1.6 DIN 125
17	1x		M8 (8) DIN980V
18	1x		System 2020-A
19	1x		
20	1x		
21	1x		
22	1x		85 kg.
23	2x		
24	1x		
25	1x		

26	1x	 	MVG-Typ: 501 S
27	1x		3515-A bis Chassis Nr.: JSAJTD44V00272097 JSAJTD54V00263188
28	1x		3515-A ab Chassis Nr.: JSAJTD44V00272098 JSAJTD54V00263189

-
- E** Volumen de suministro del enganche
-
- D** Lieferumfang der Anhängervorrichtung
-
- GB** Scope of delivery of towing hitch
-
- F** Pièces comprises dans la fourniture de l'attelage
-
- NL** Leveringsomvang trekhaak
-
- S** Dragkrokens leveransspecifikation
-
- CZ** Objem dodání tažného zařízení
-
- I** Dotazione del gancio di traino
-

bis Chassis Nr.:
JSAJTD44V00272097
JSAJTD54V00263188

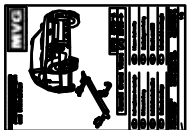

27

ab Chassis Nr.:
JSAJTD44V00272098
JSAJTD54V00263189

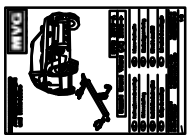

28

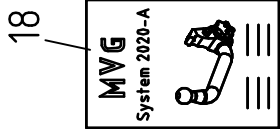

18

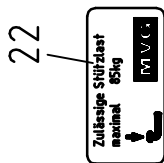

22



21

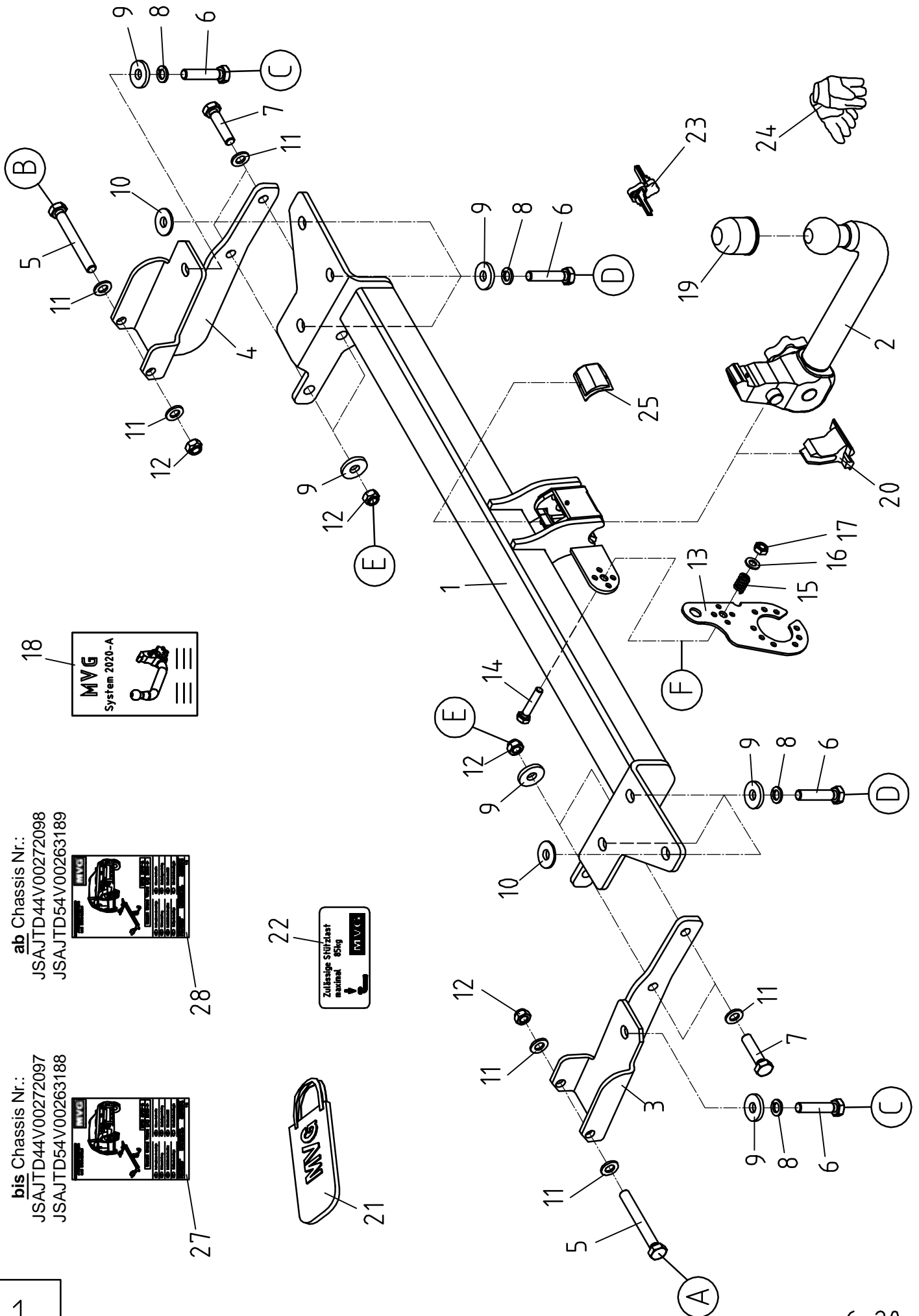

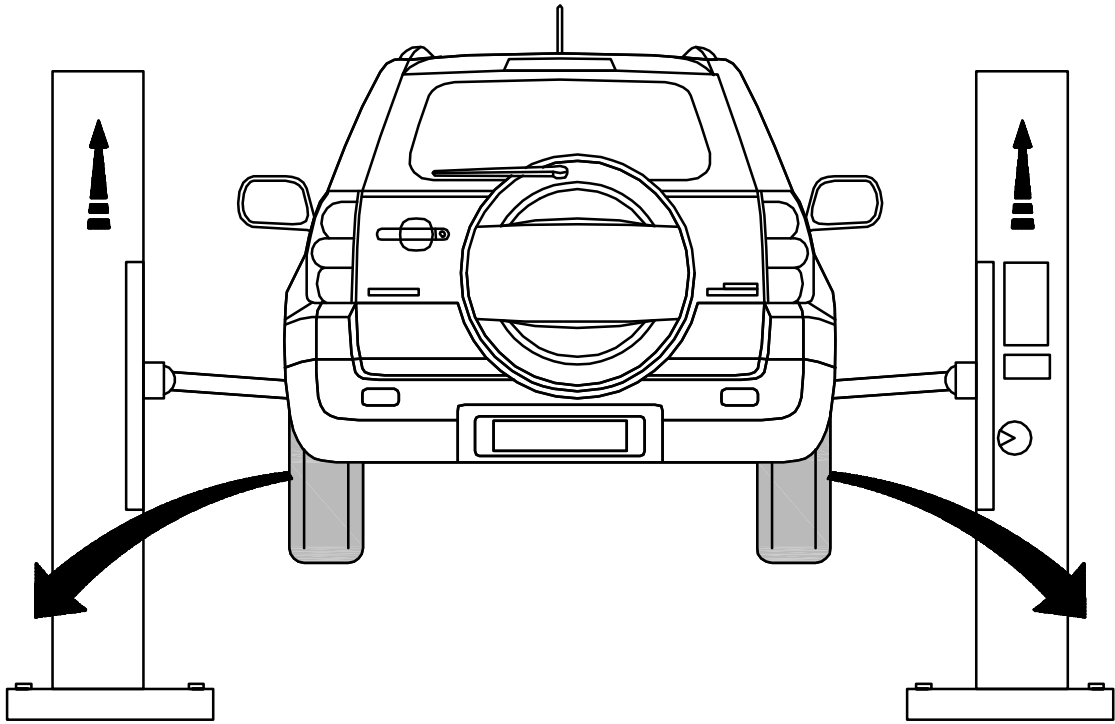
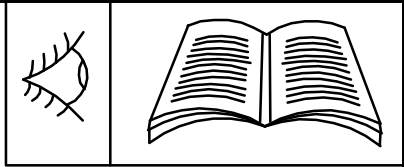

2

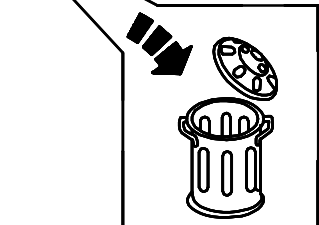
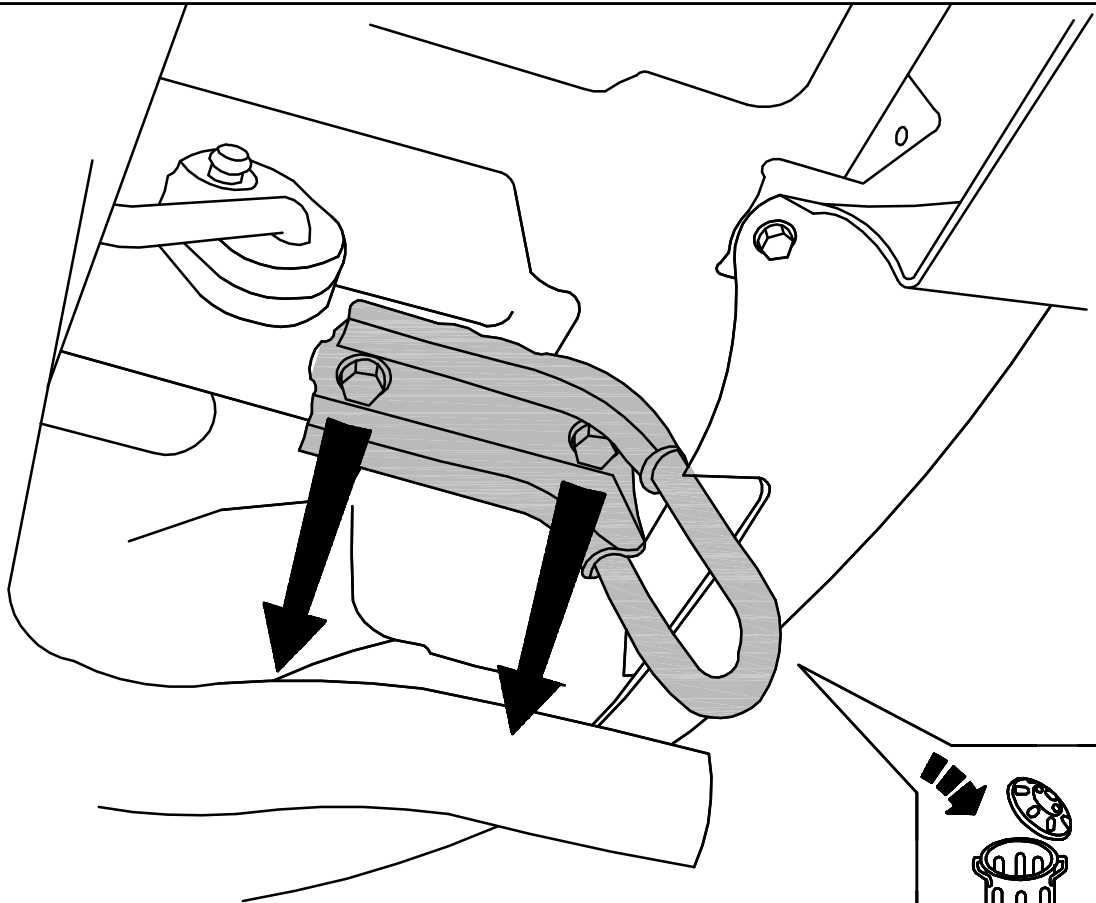
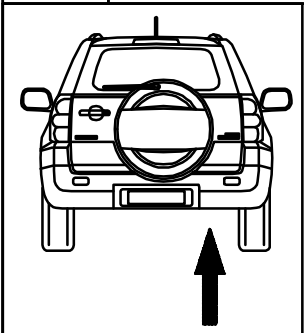

3

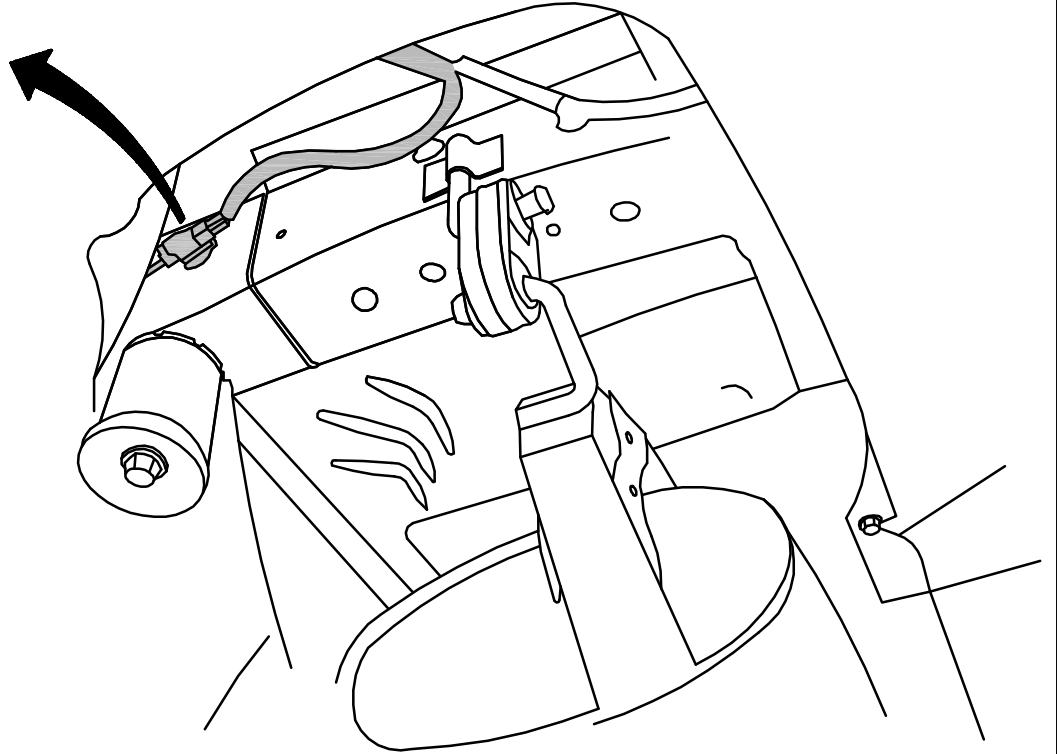
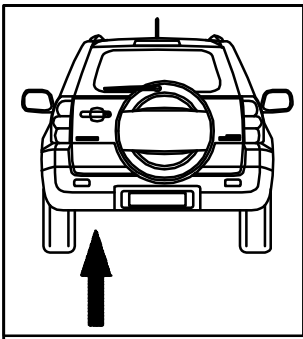

4

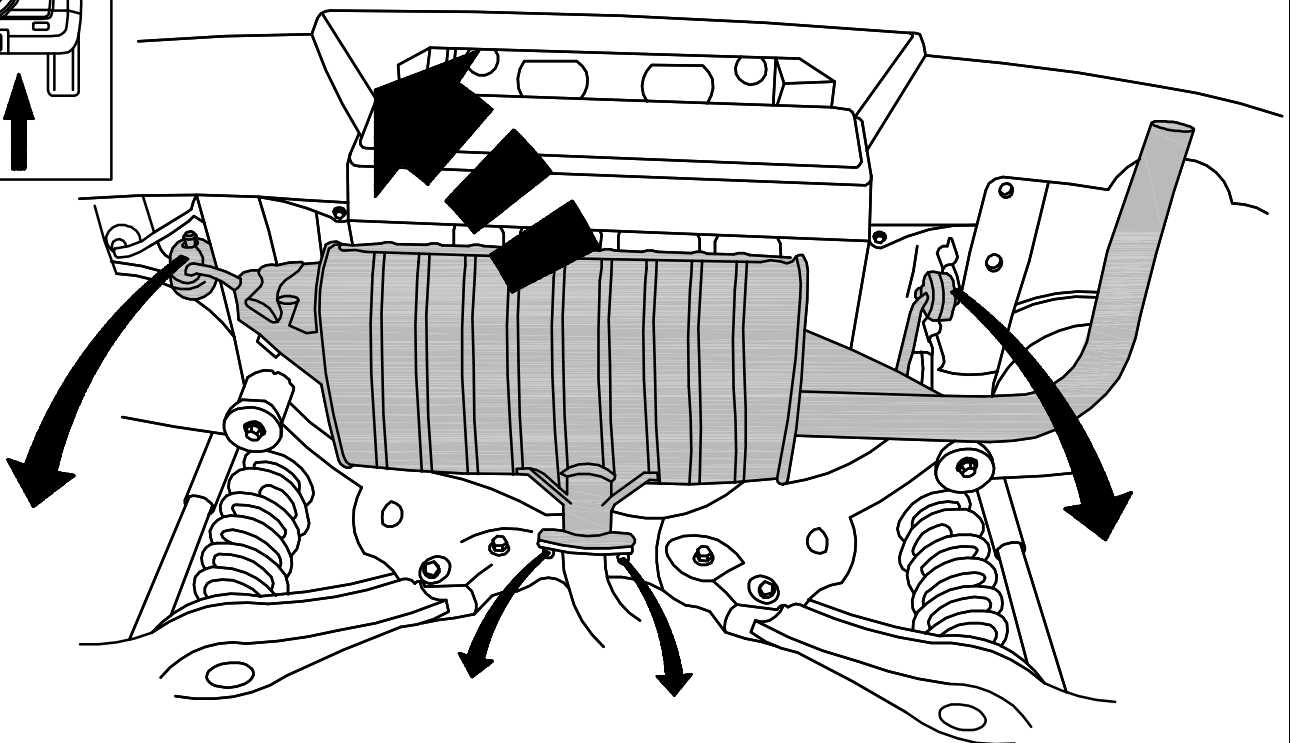
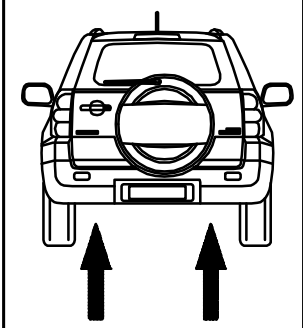

5

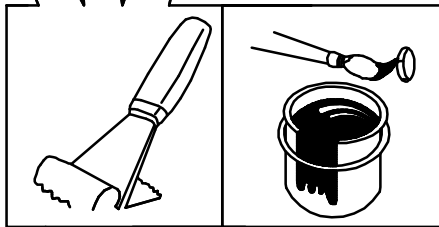
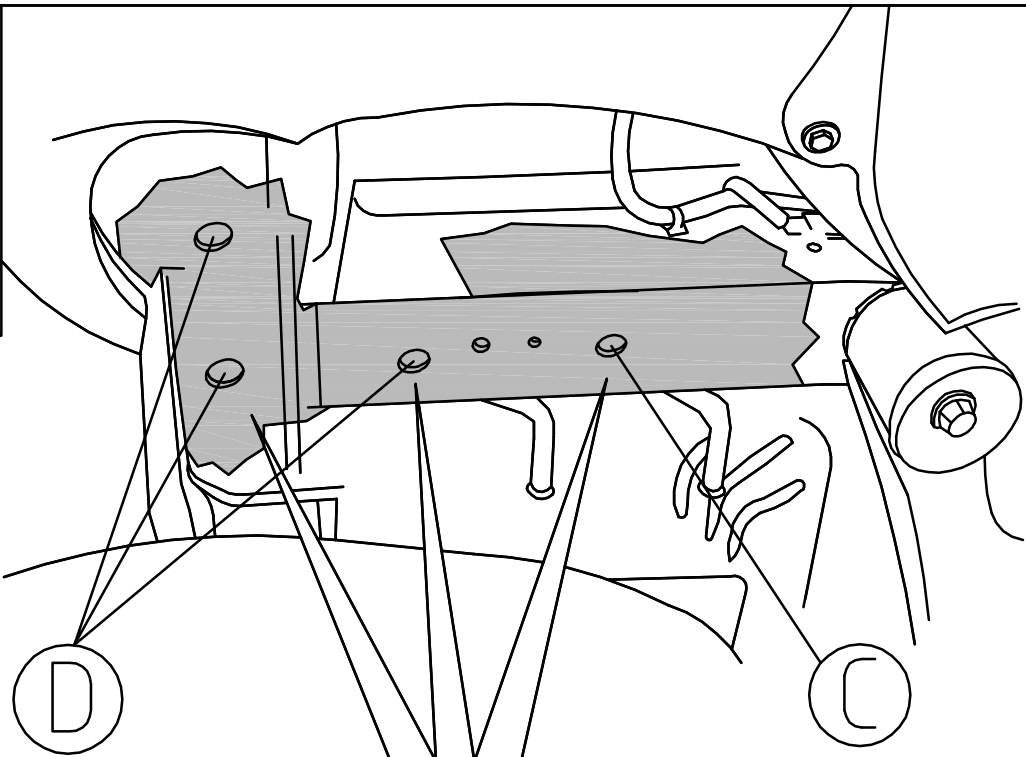
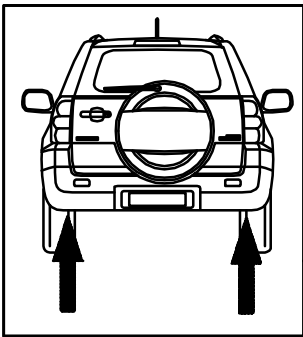

6

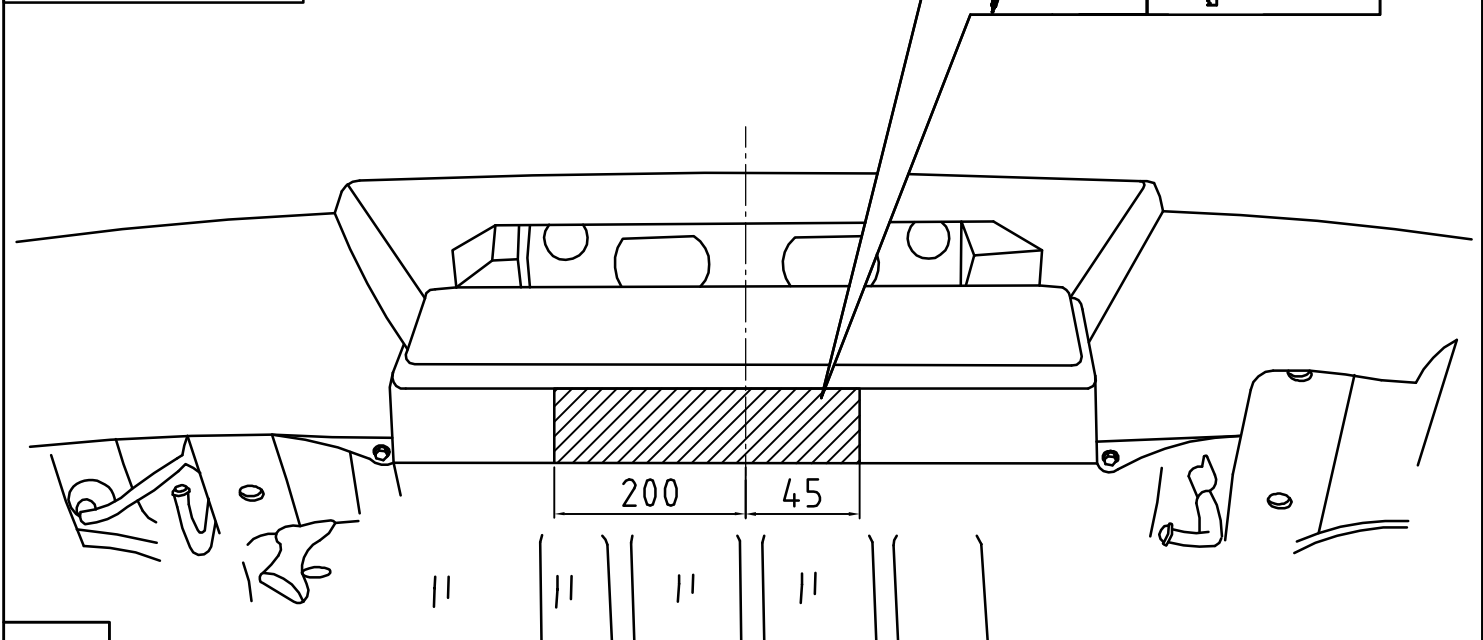
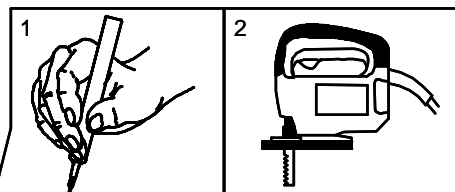
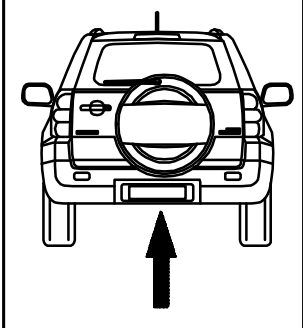

7



1.

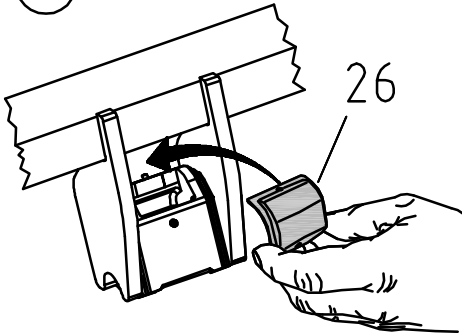

2.

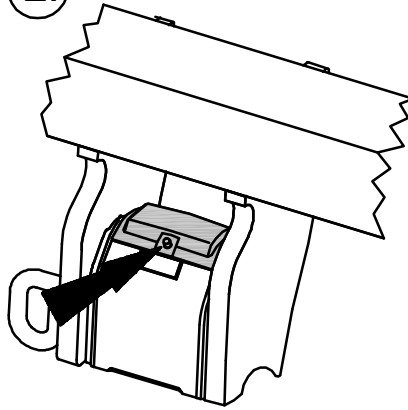

3.

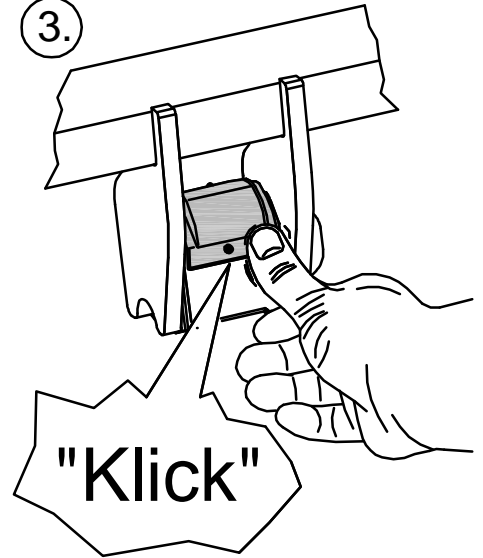

8

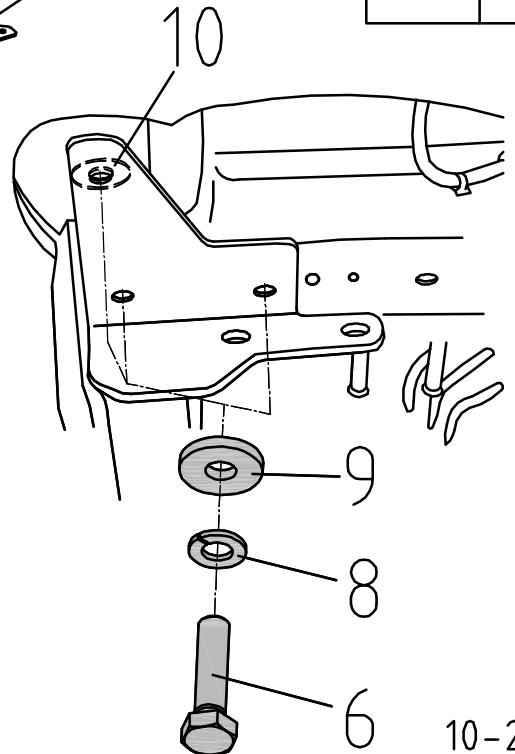
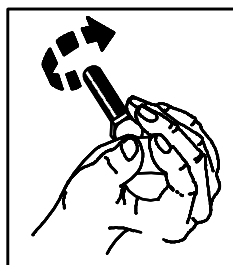
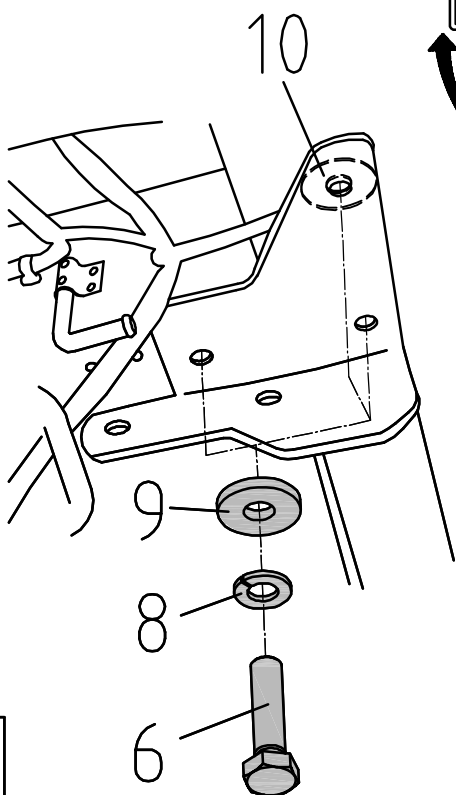
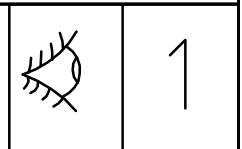
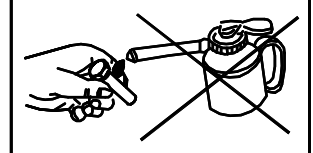
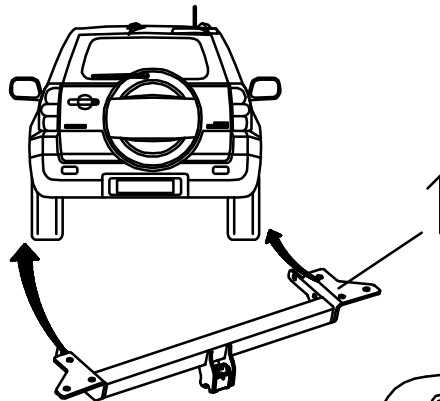

9

10-20

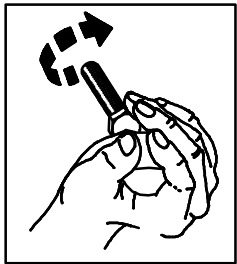
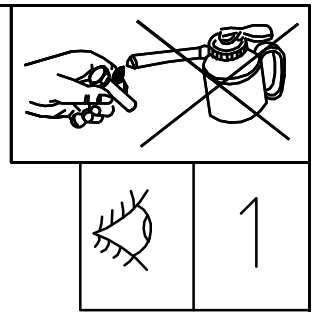
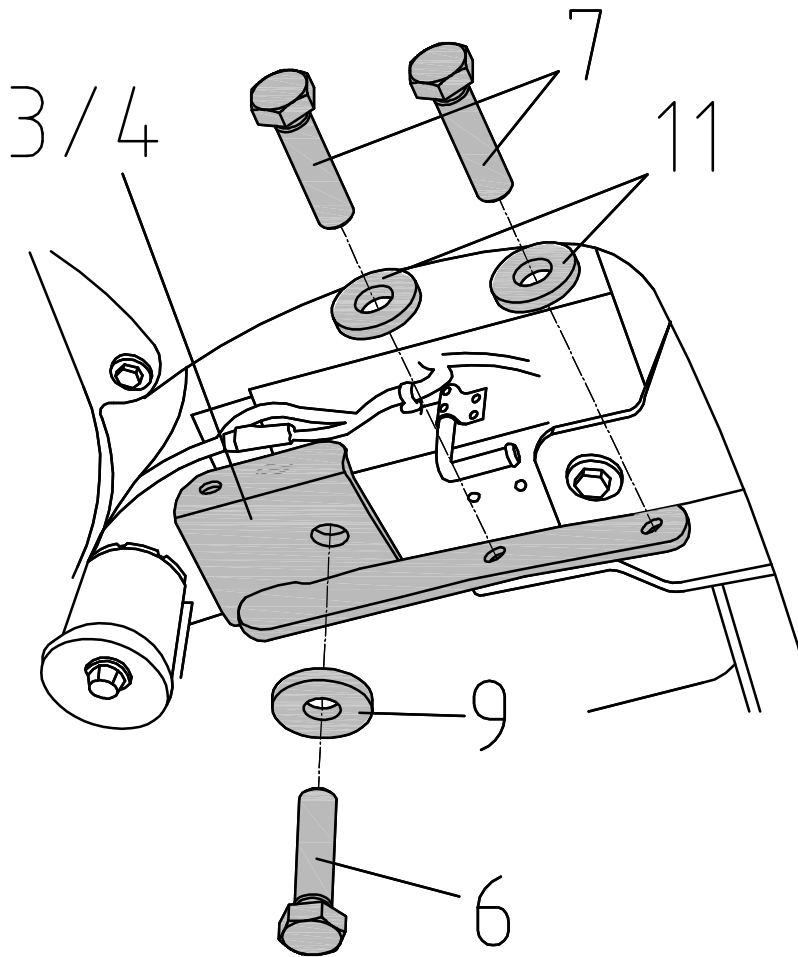
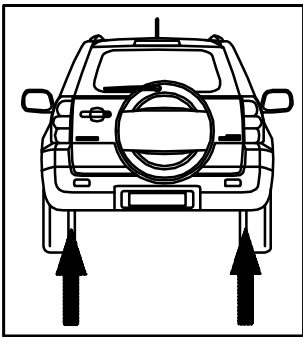

10

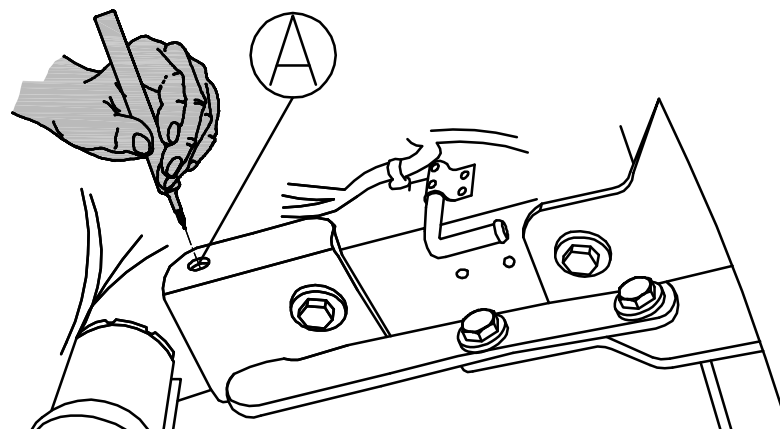
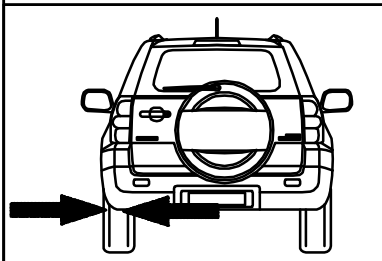
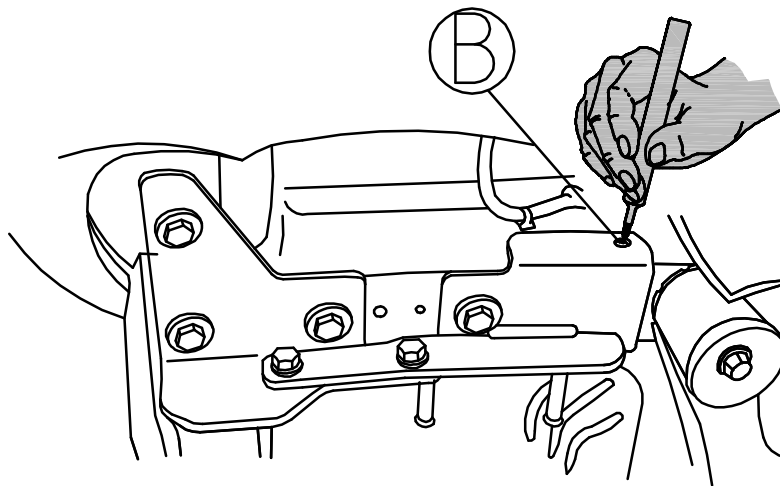
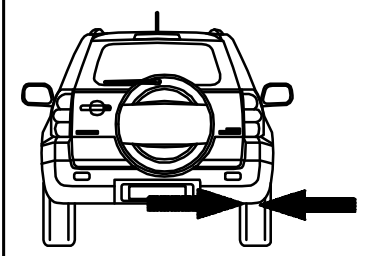

11

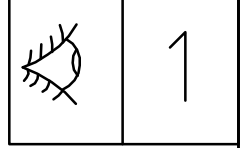
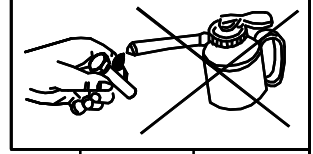
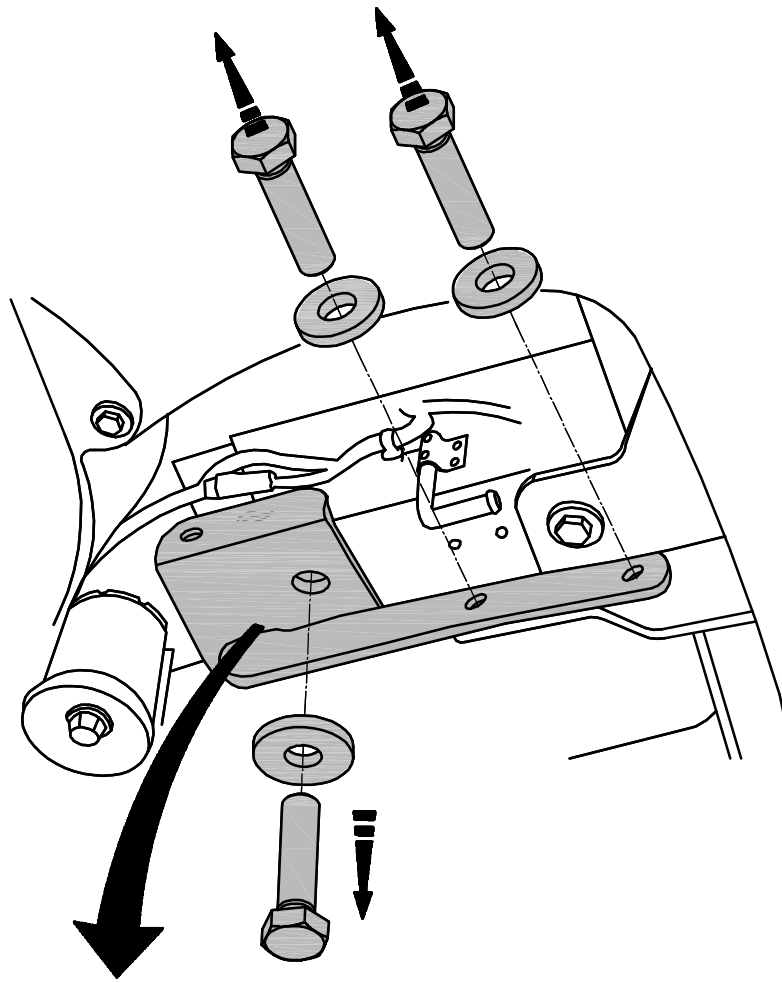
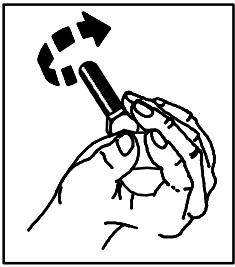
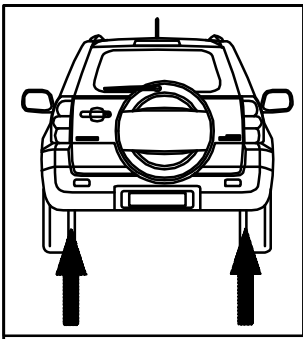

12

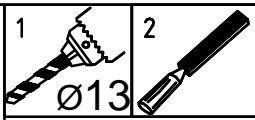
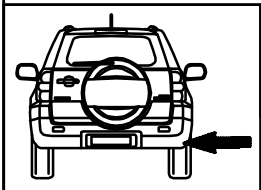
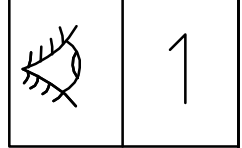
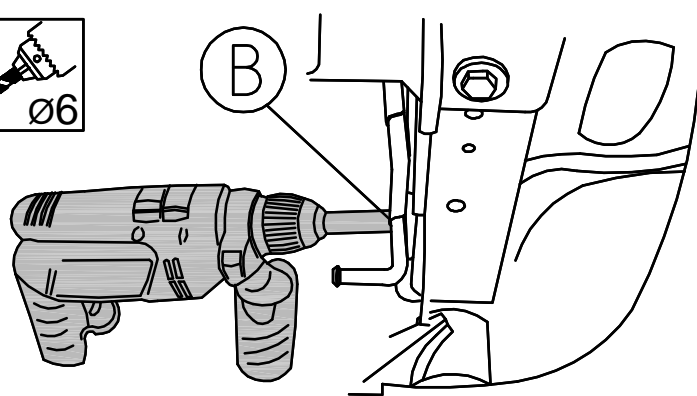
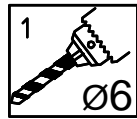
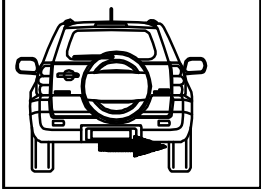

B

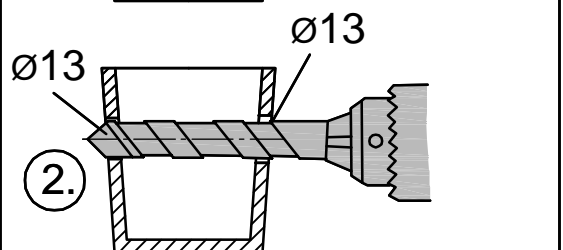
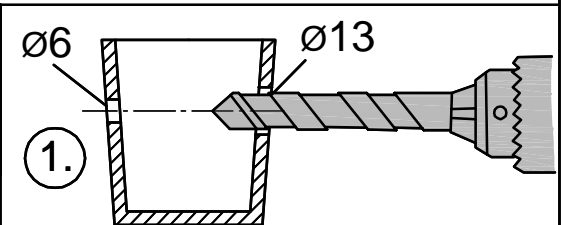
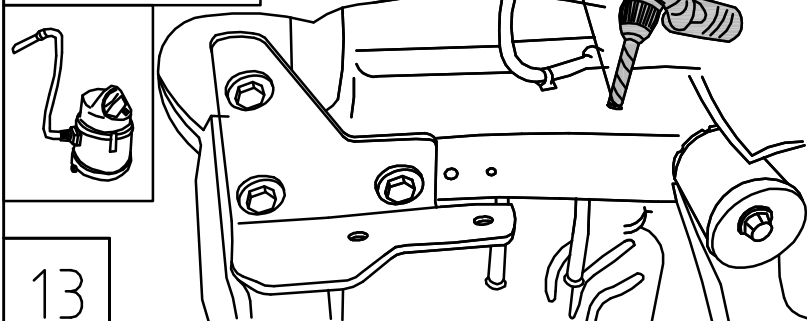
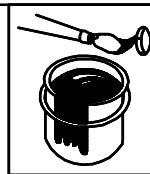

13

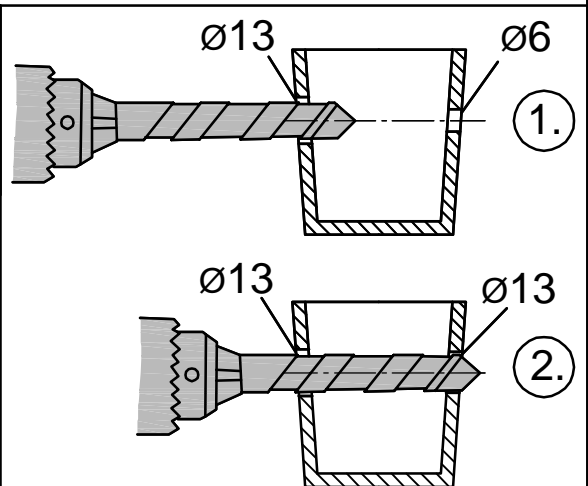
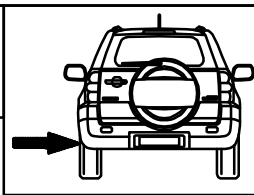
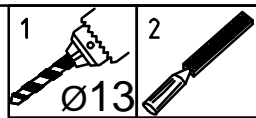
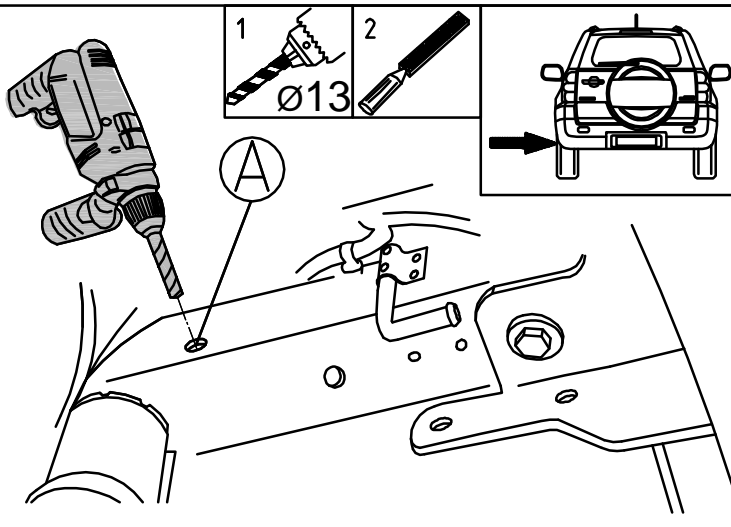
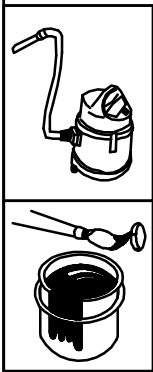
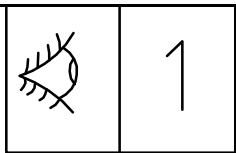
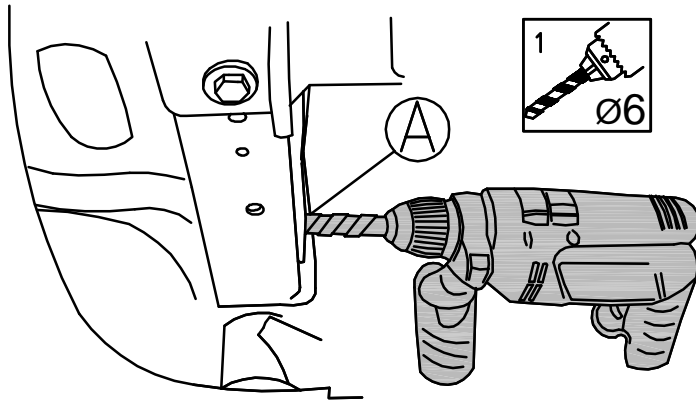
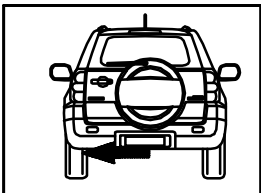

14

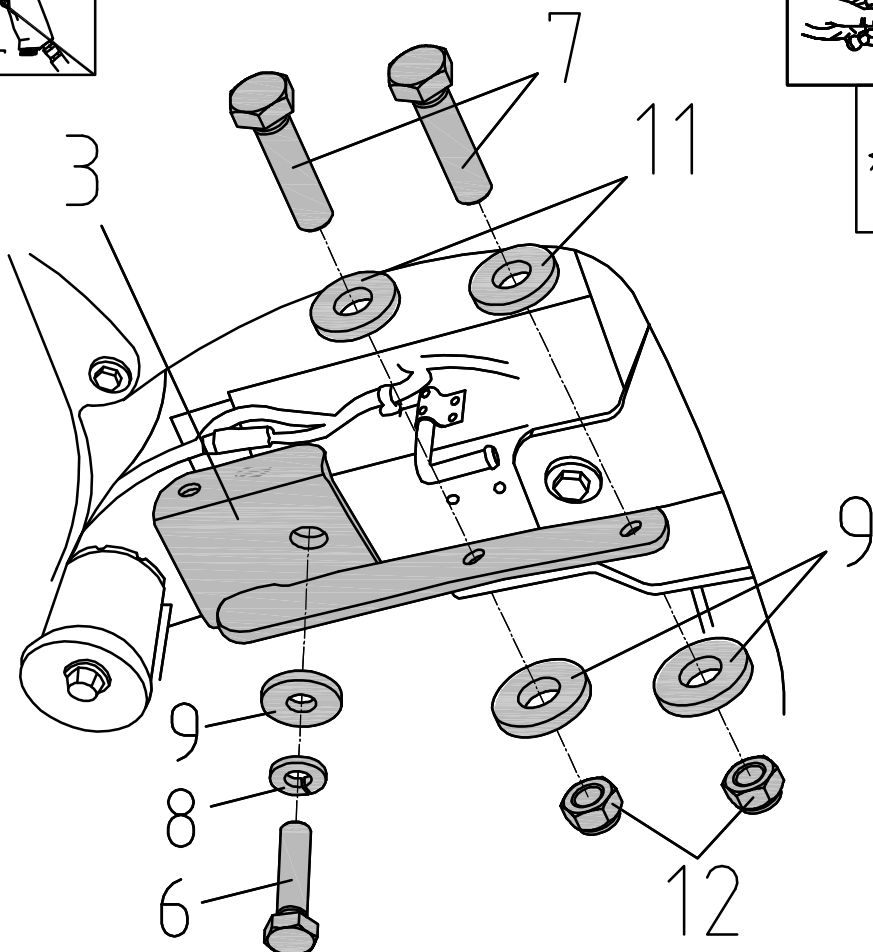
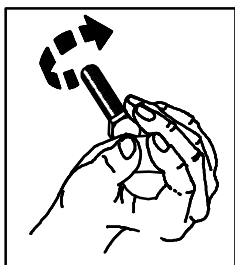
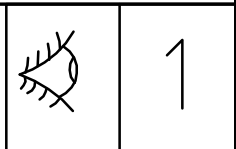
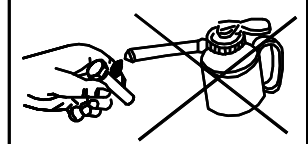
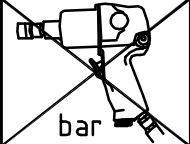
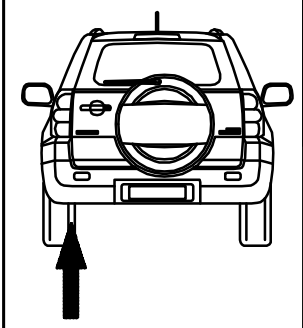

15

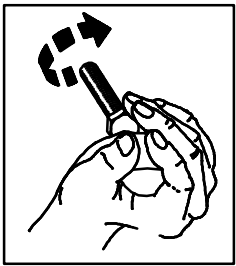
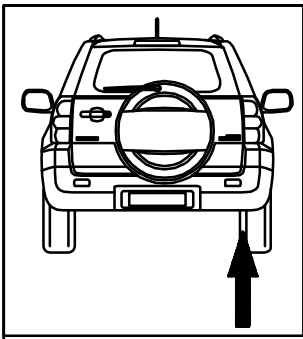

16

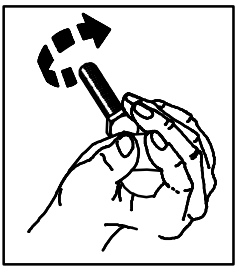
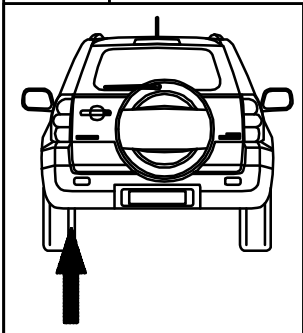
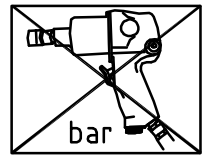
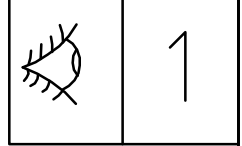
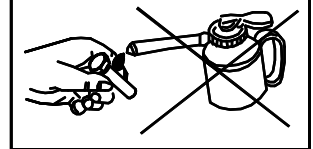
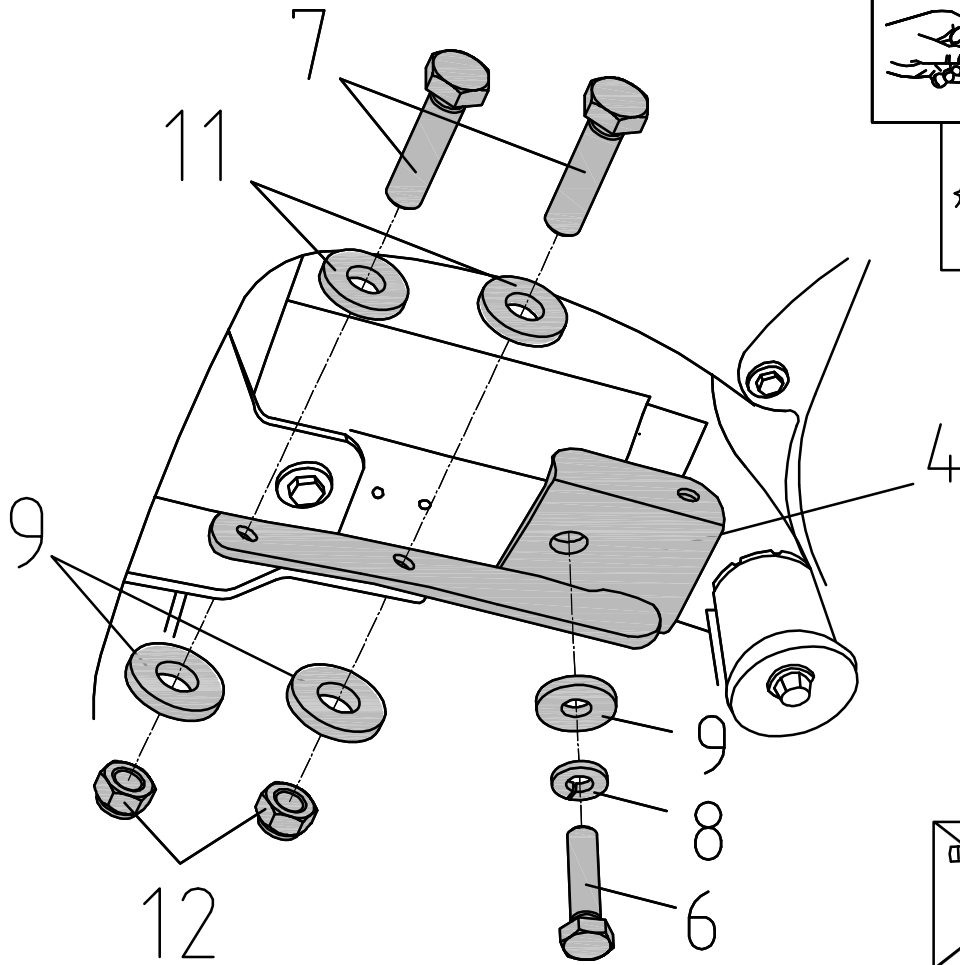

17

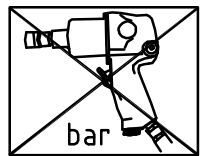
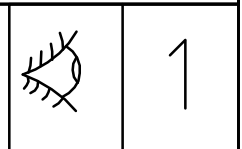
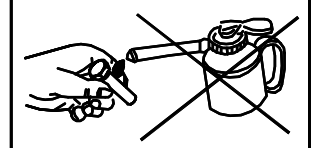
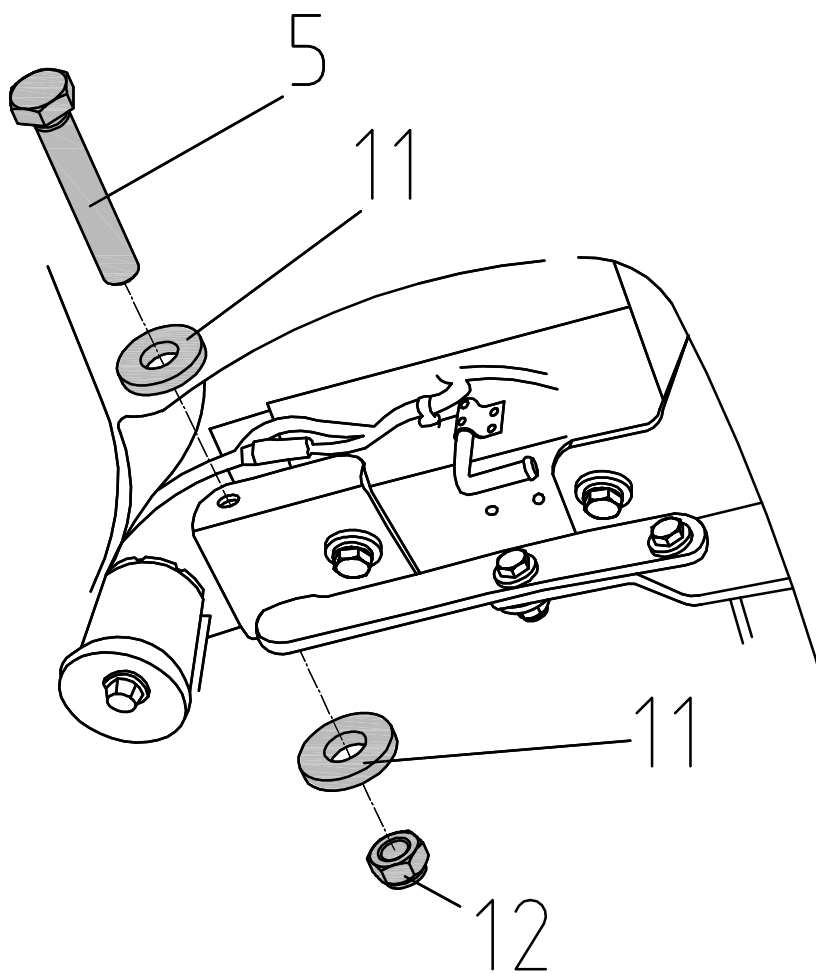

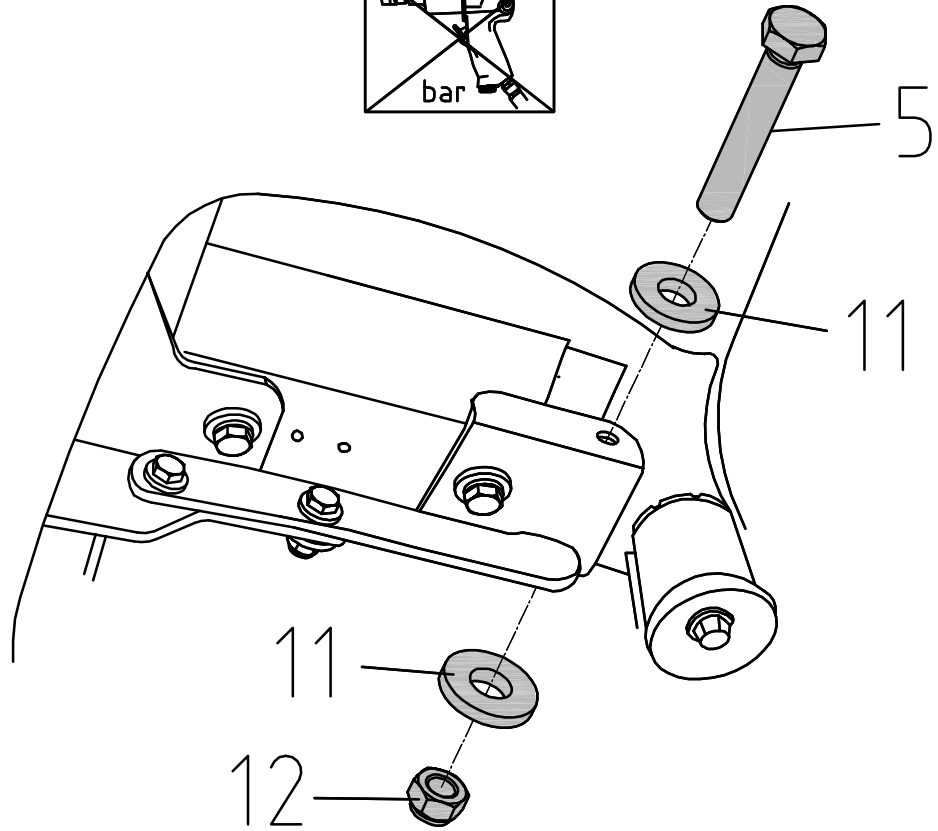
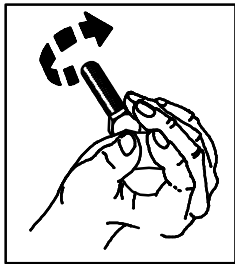
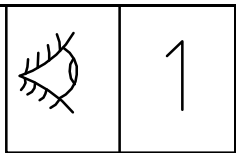
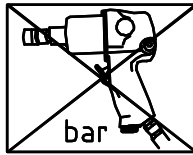
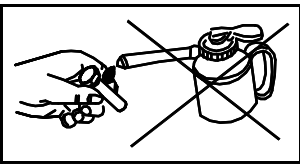
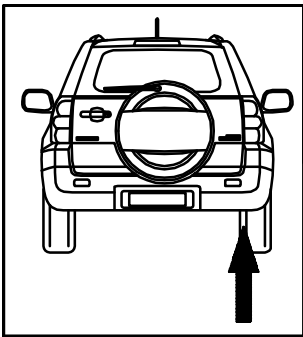

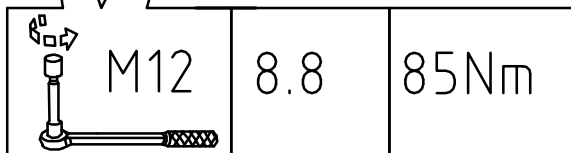
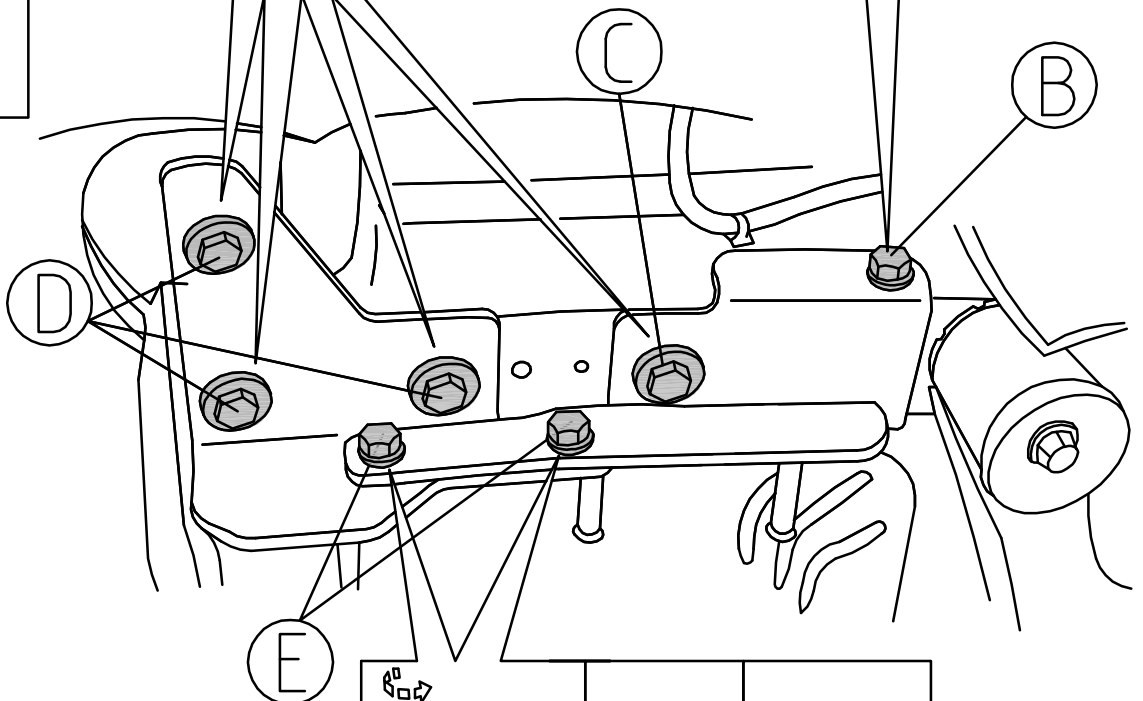
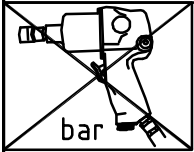
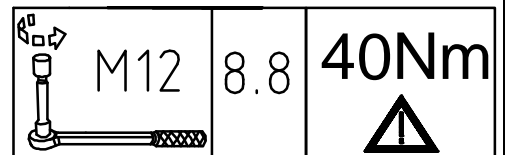
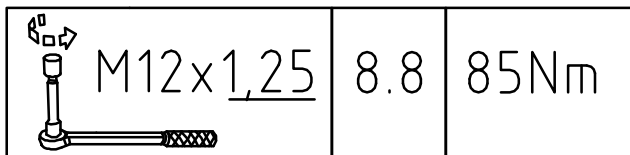
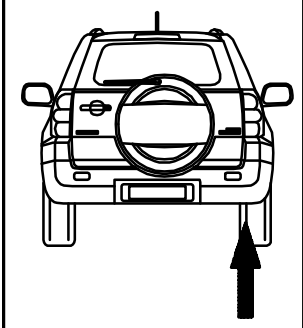

18

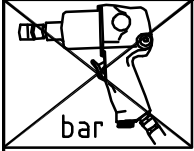
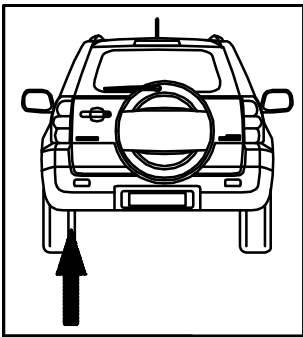

19



	M12x1,25	8.8	85Nm
---	----------	-----	------

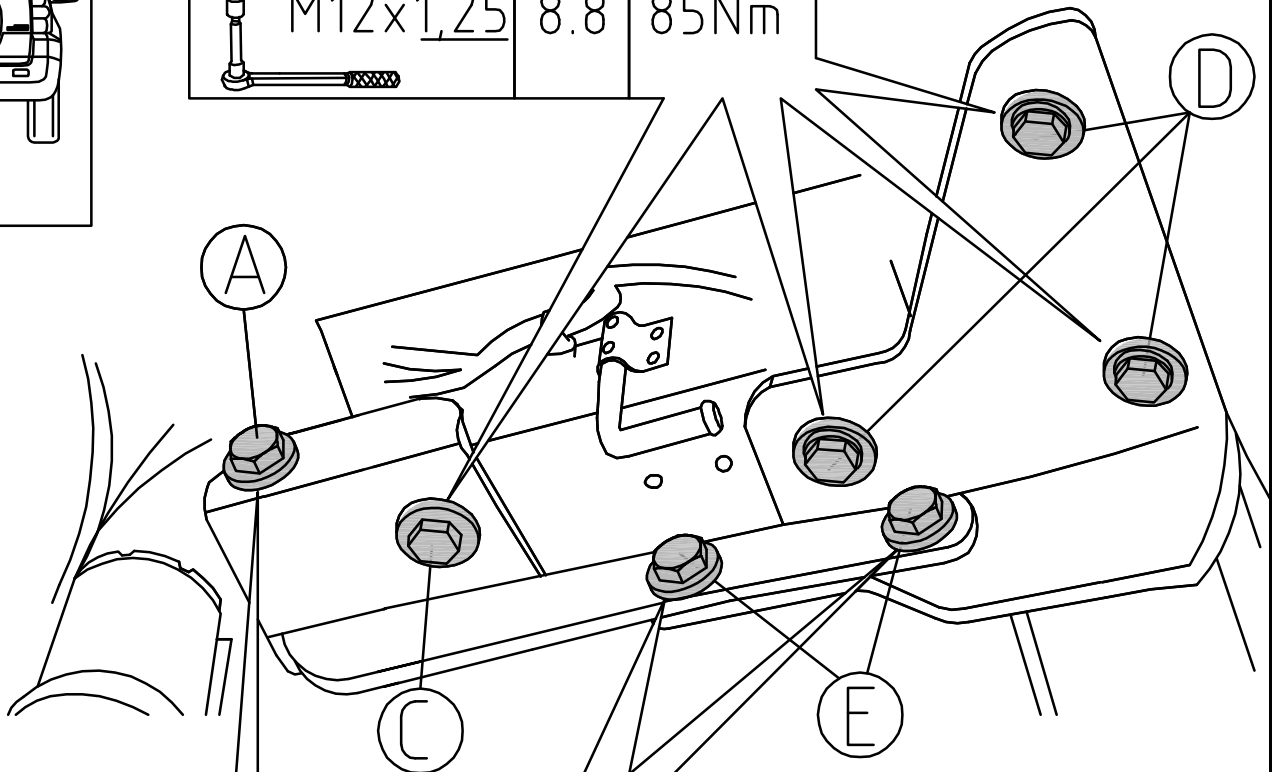

	M12	8.8	40Nm
--	-----	-----	------

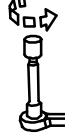
	M12	8.8	85Nm
--	-----	-----	------

20

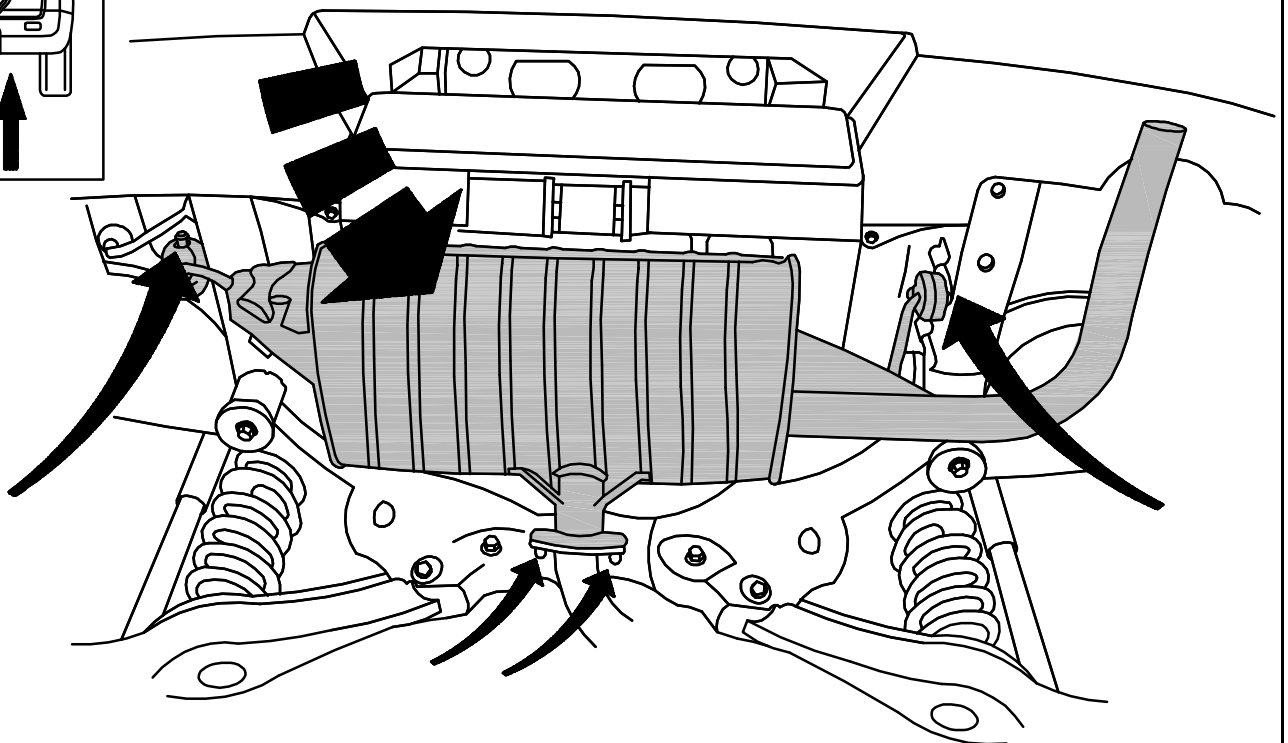
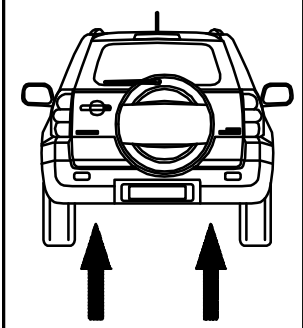

21

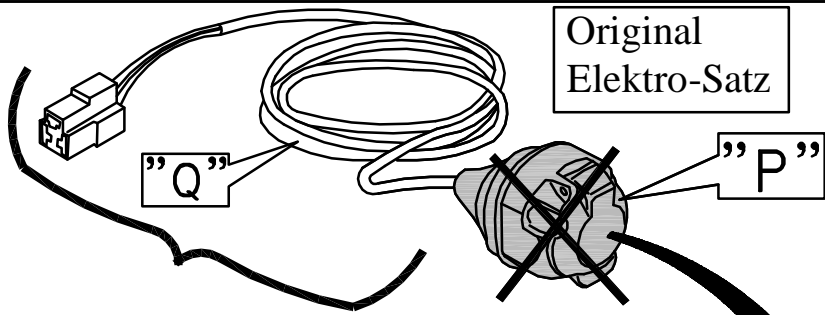

MVG-Typ: 501 S

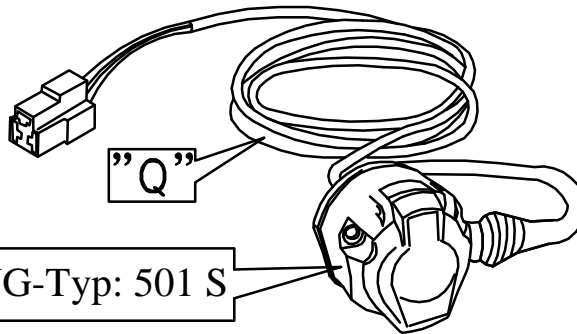
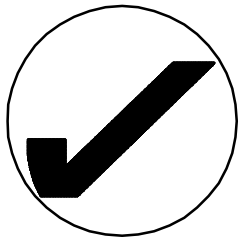
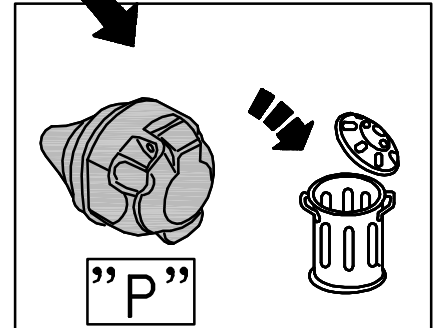
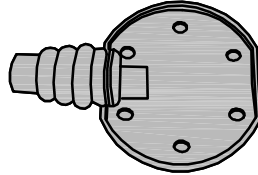
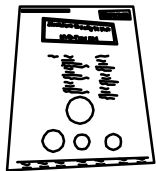

MVG-Typ: 501 S

22

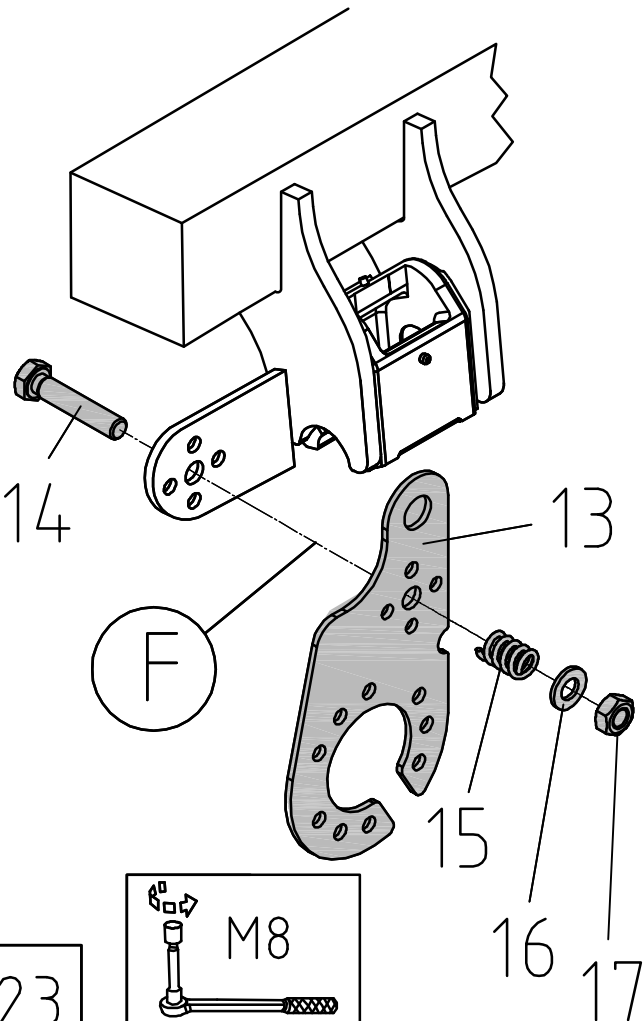

23

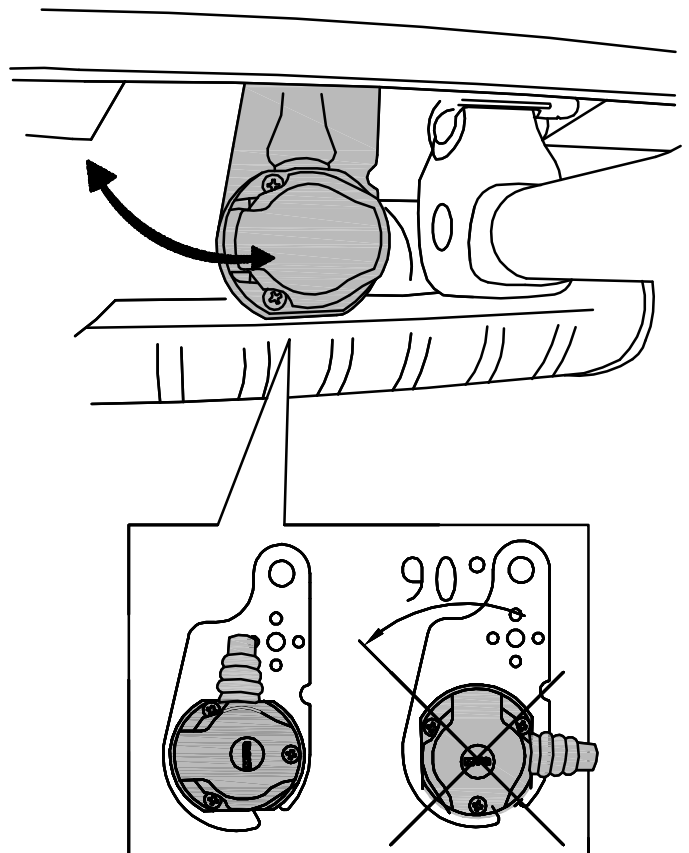

17-20

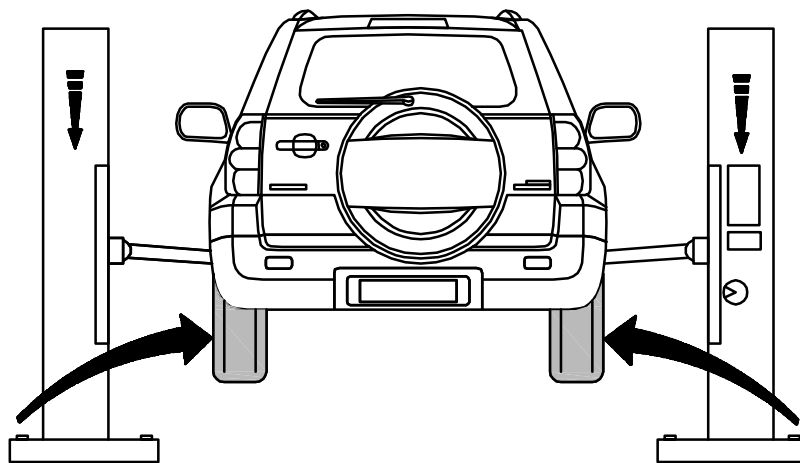
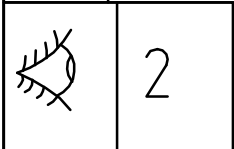
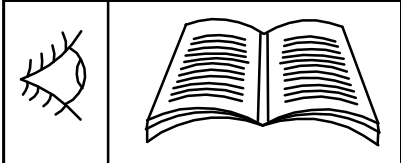
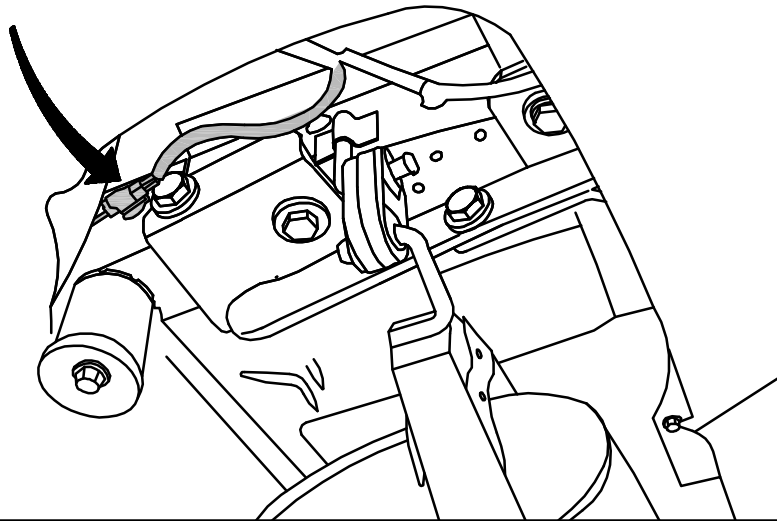
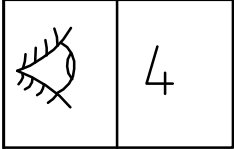
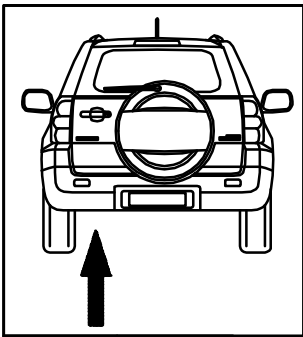

24

Zulässige Stützlast
maximal 85 kg

MVG

22

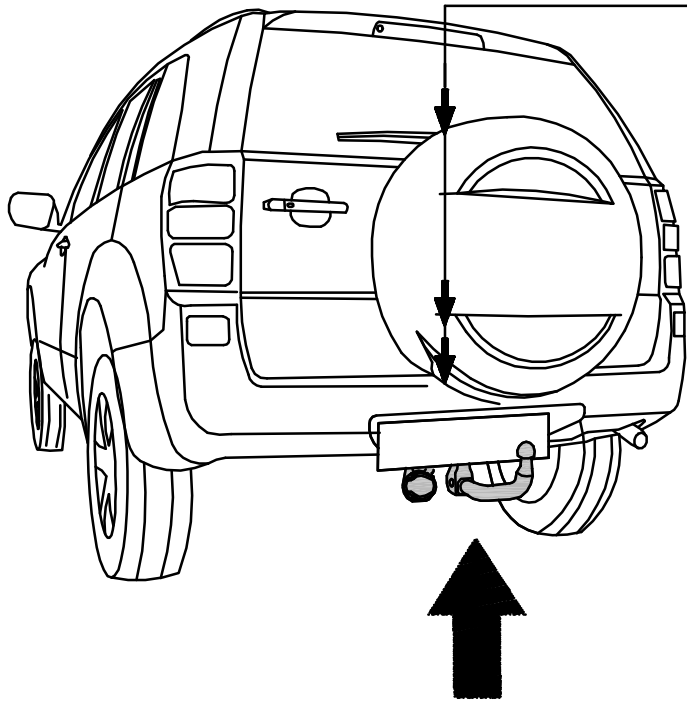

18

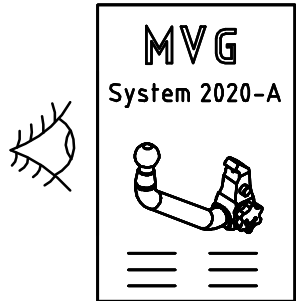

25

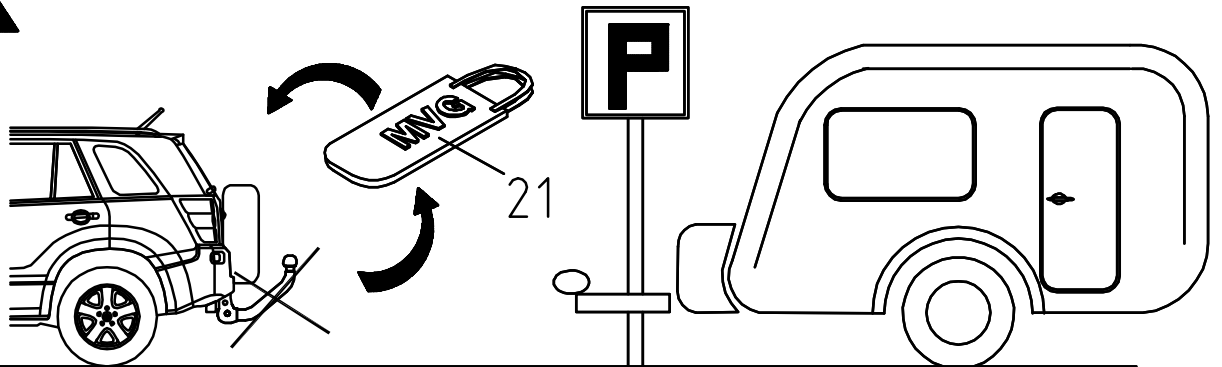
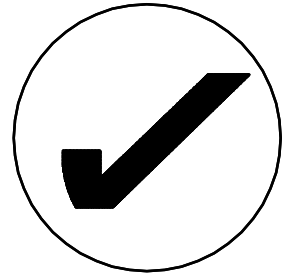
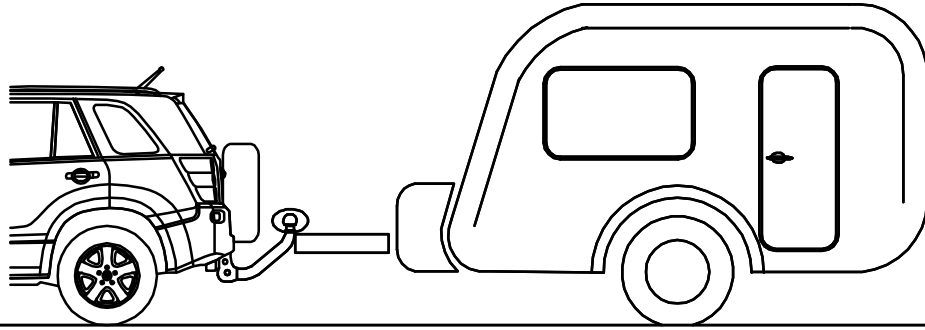

26

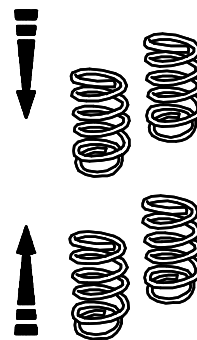
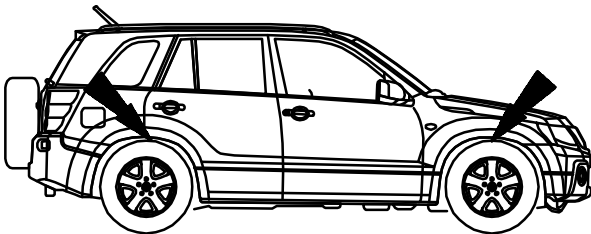
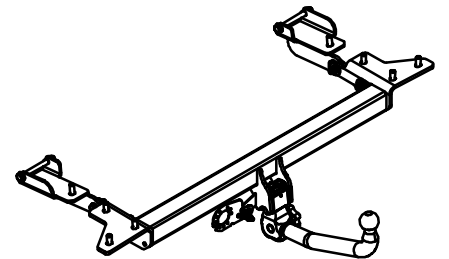
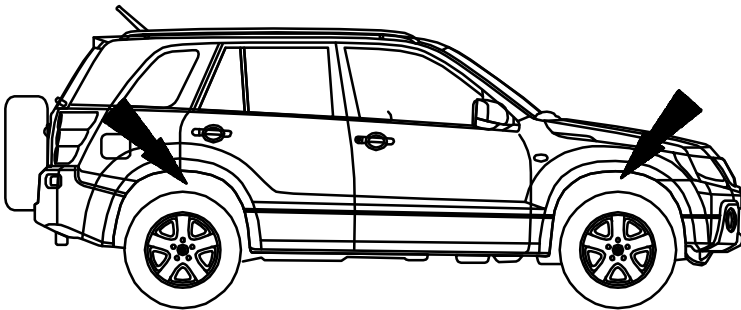

Best. Nr.: 3515-A

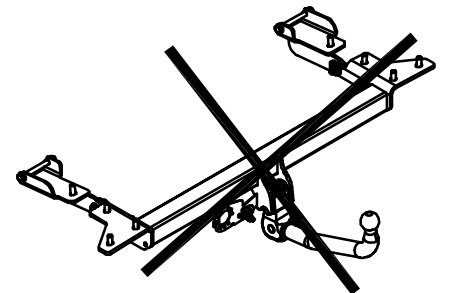
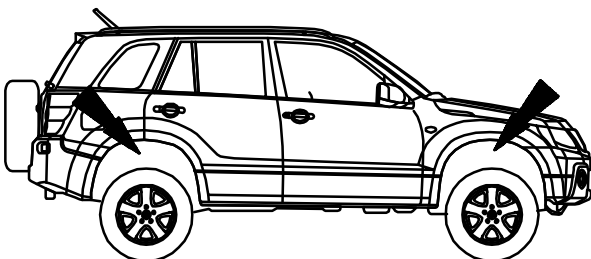

27

Technische Änderungen vorbehalten

19-20

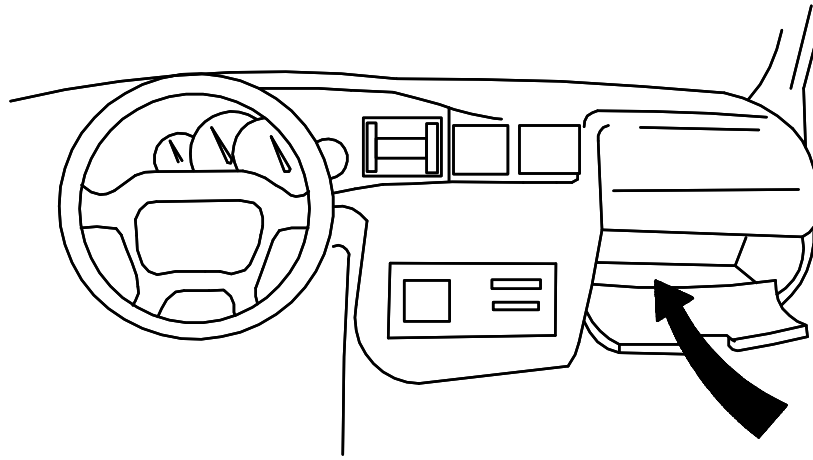

27/28

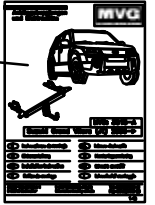

18

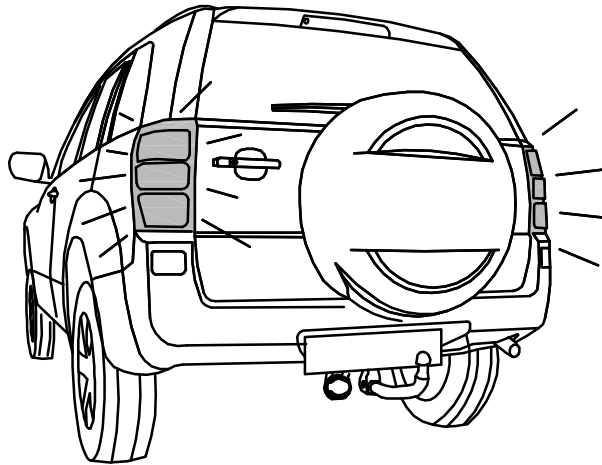
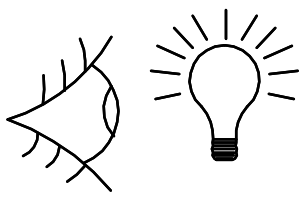
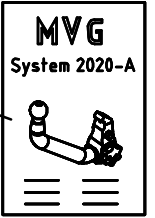

28