

MVG: 0595 B

Mazda CX-5 (KE)

E Instrucciones de montaje

D Einbauanleitung

GB Installation instruction

F Notice de montage

NL Inbouw instructie

S Monteringsanvisning

CZ Návod k montáži

I Istruzioni di montaggio

An der Wasserwiese 1
D-52249 Eschweiler

E-mail: info@mvg-ahk.de
Internet: www.mvg-ahk.de

Tel.: 0049 (0)2403/7902-60
Fax: 0049 (0)2403/7902-99

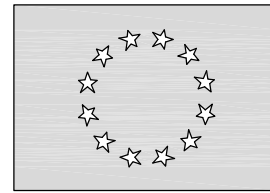
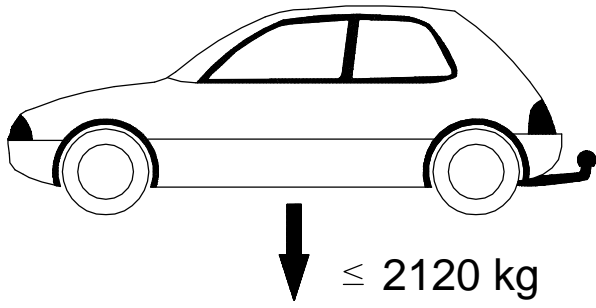

EG
e13 * 2007/46 * 1247

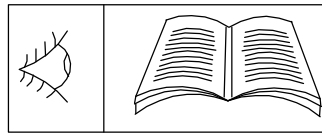

$$D = 11,0 \text{ kN}$$

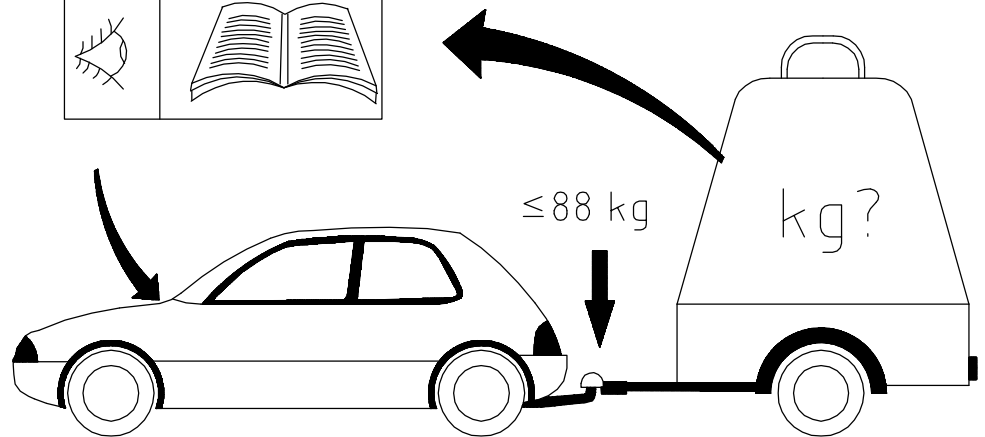

$$g = 9,81 \text{ m/s}^2$$



$$D = \frac{T \times R}{1000 \times (T+R)} \times g$$

$$T = \frac{R \times D \times 1000}{g \times R - 1000 \times D} \times g$$

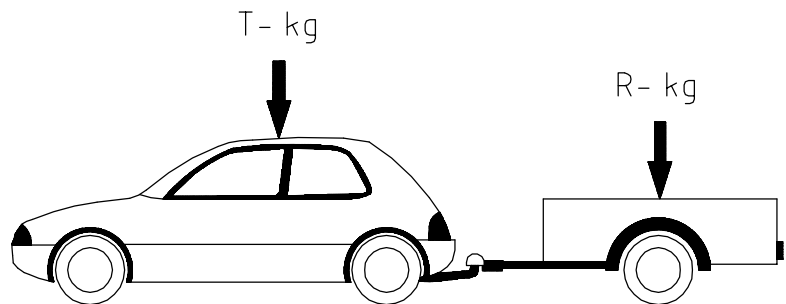
$$R = \frac{T \times D \times 1000}{g \times T - 1000 \times D}$$

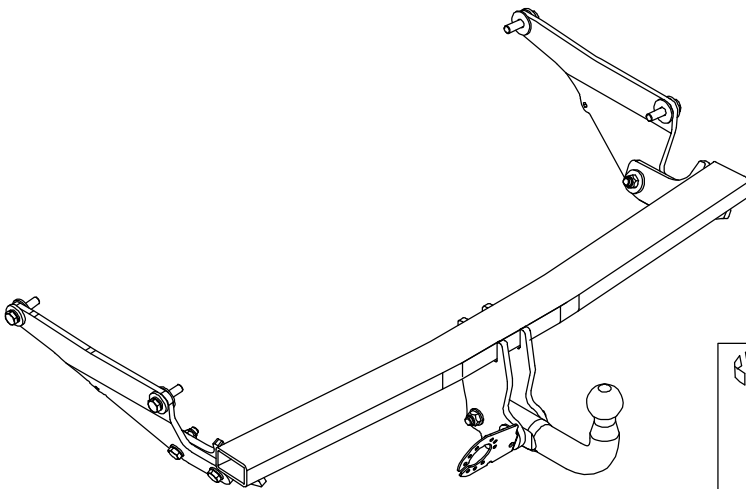
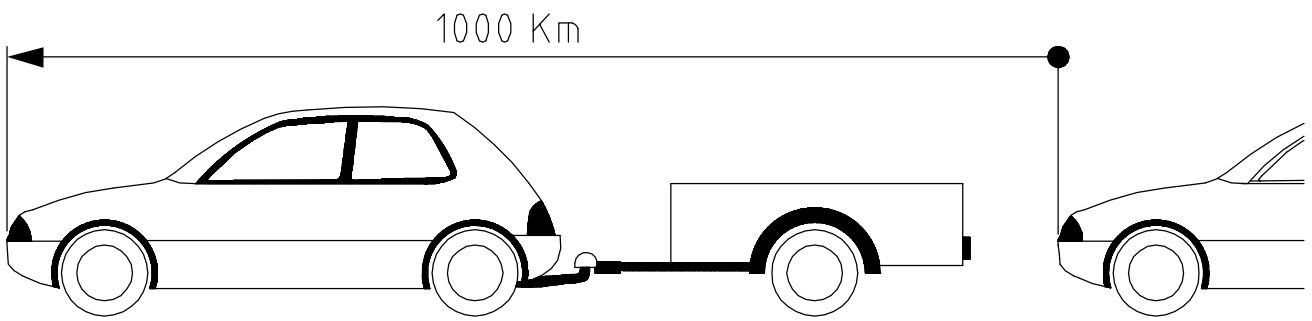
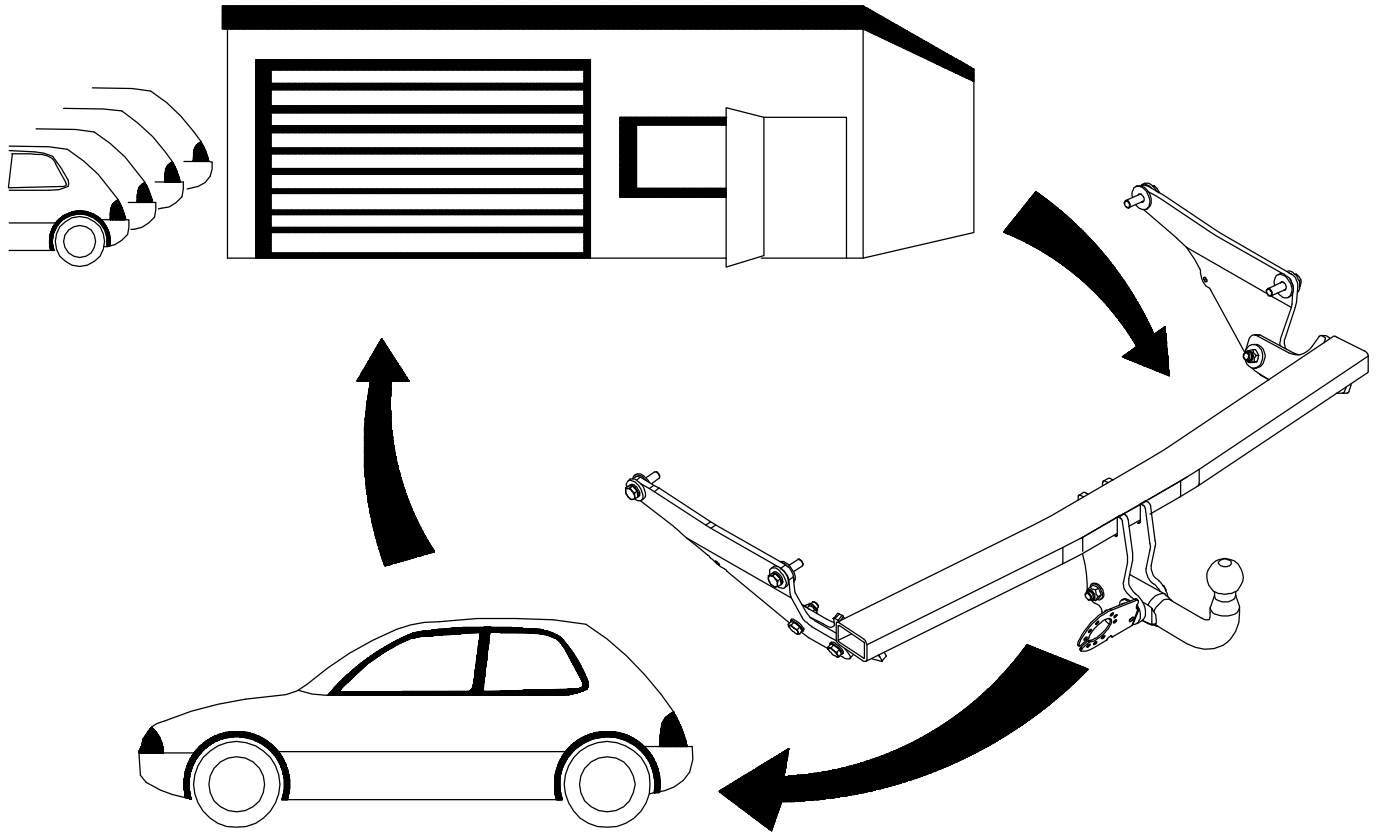

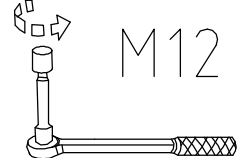

| | | |
|---|---|--|
|  <p>M12</p> | <p>0 Km</p>  | <p>1000 Km</p>  |
|---|---|--|

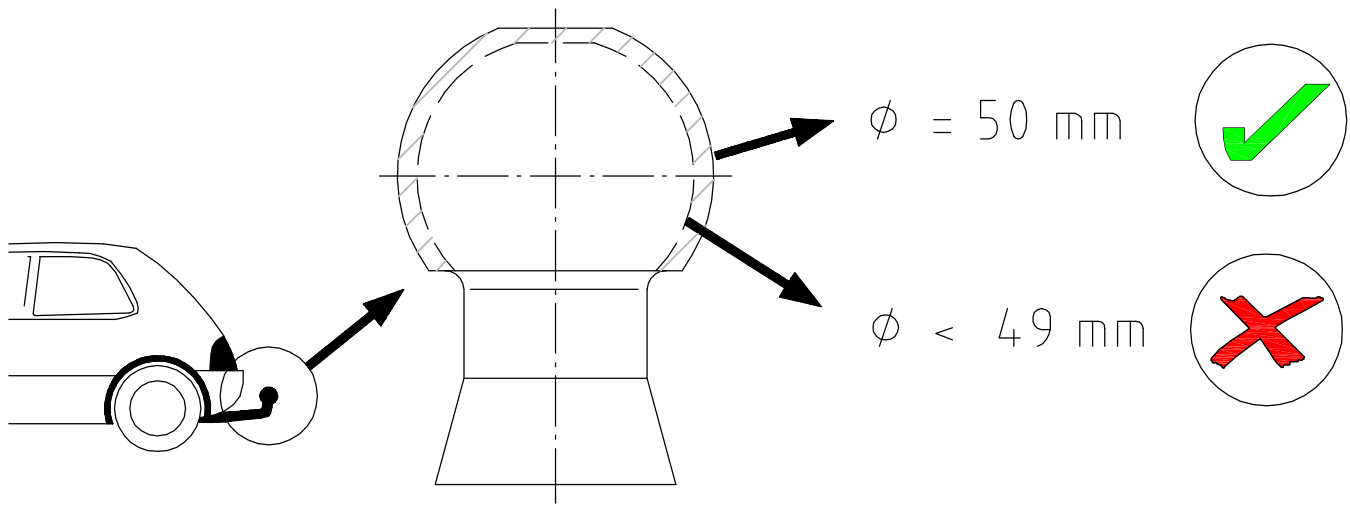







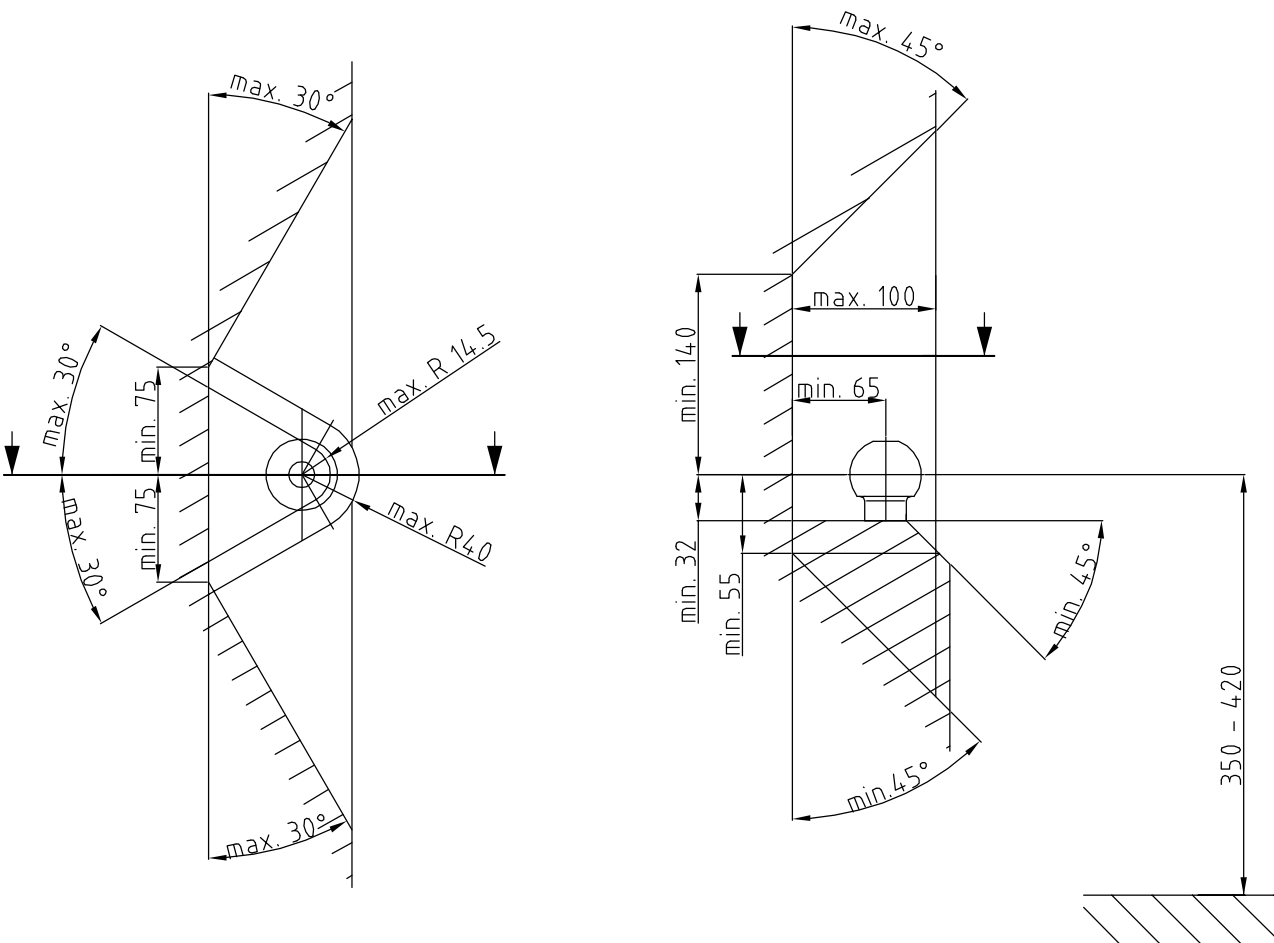

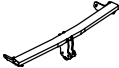

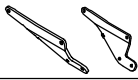







 Approval Number
E4 55R-01 0161
 Type: 0595 B D-Value: 11,0 kN
 Class: A50-X S-Value: 100 kg
 Made in Germany www.mvg-ahk.de

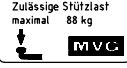

Zulässige Stützlast maximal 88 kg



www.mvg-ahk.de



| | | | | |
|----|-----|---|-------------------------------------|------|
| 1 | 1x |  | 0595 B | |
| 2 | 1x |  | 2000-B-35.1 | |
| 3 | je1 |  | | |
| 4 | 4x |  | M12x <u>1,25</u> x50 (8.8) ISO 8676 | |
| 5 | 4x |  | M12x45 (8.8) ISO 4014 | |
| 6 | 4x |  | ∅ 13/29x3 (St.) ISO 7093 | |
| 7 | 8x |  | ∅ 13/35x5 (St.) DIN 6340 | |
| 8 | 7x |  | ∅ 13/24x2,5 (St.) ISO 7089 | |
| 9 | 4x |  | A 12 (Fst.) DIN 127 | |
| 10 | 6x |  | M12 <u>(10)</u> ISO 7042 | |
| 11 | 2x |  | M12x80 <u>(10.9)</u> ISO 4014 | |
| 12 | 1x |  | | |
| 13 | 1x |  | 0595 B | |
| 14 | 1x |  | | 0069 |
| 15 | 1x |  | 88 kg. | 1016 |
| 16 | 2x |  | | |

| | | | | |
|----|----|---|-----------------------|--|
| 17 | 2x |  | | |
| 18 | 2x |  | M12x50 (8.8) ISO 4014 | |

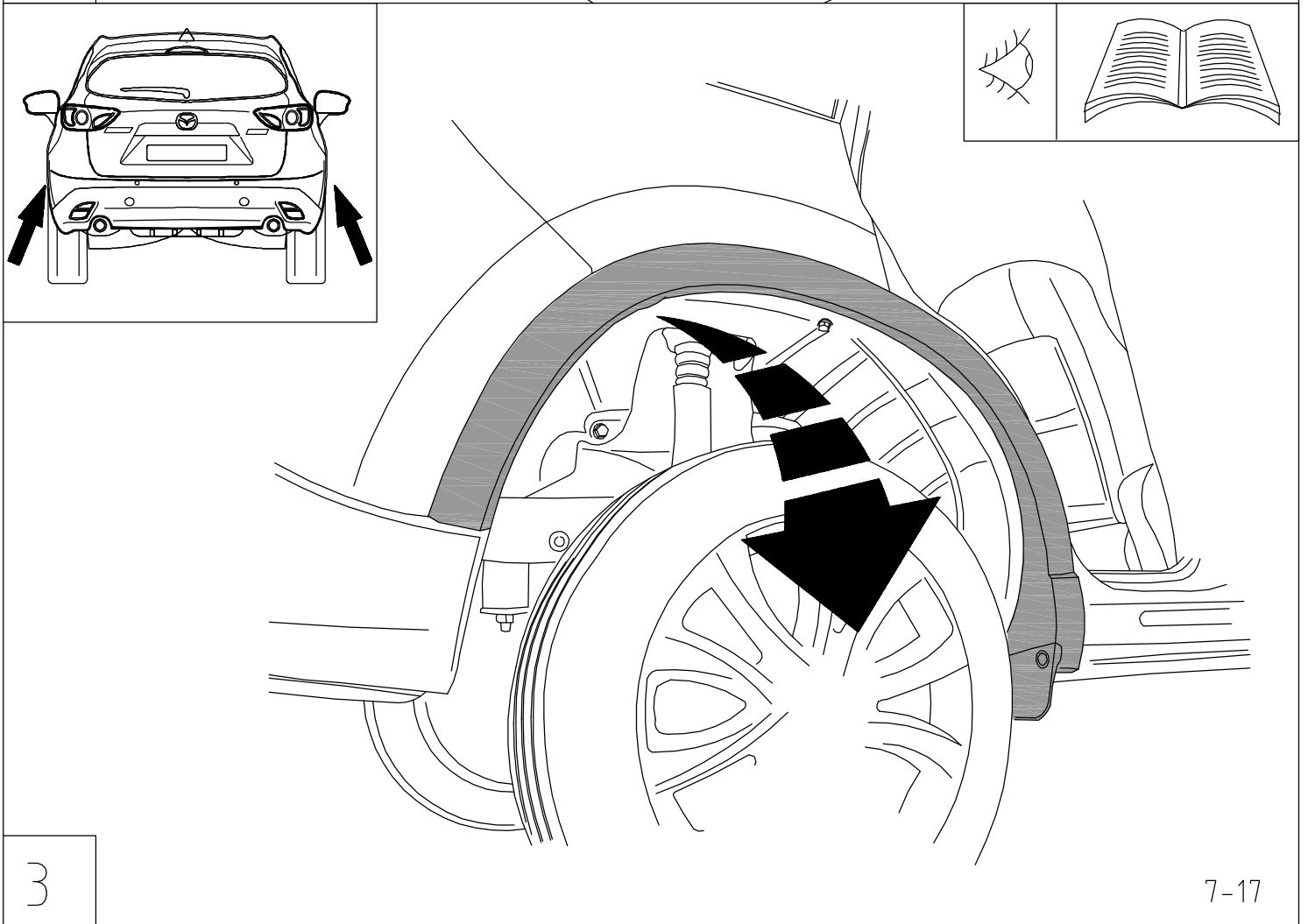
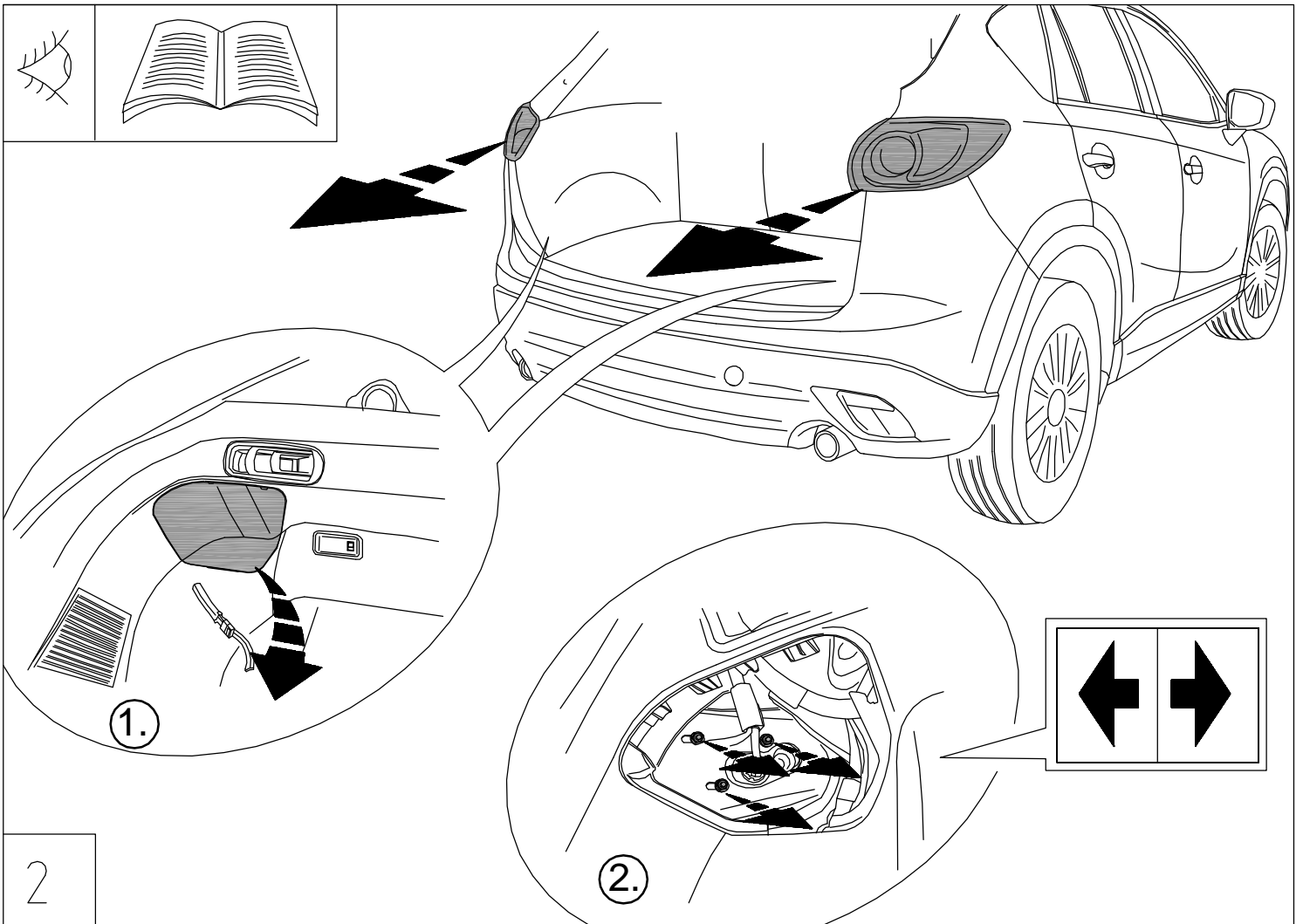
| | |
|---|---|
|  | Volumen de suministro del enganche |
|  | Lieferumfang der Anhängervorrichtung |
|  | Scope of delivery of towing hitch |
|  | Pièces comprises dans la fourniture de l'attelage |
|  | Leveringsomvang trekhaak |
|  | Dragkrokens leveransspecifikation |
|  | Objem dodání tažného zařízení |
|  | Dotazione del gancio di traino |



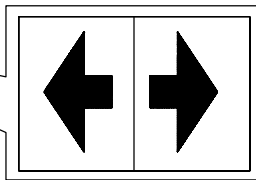
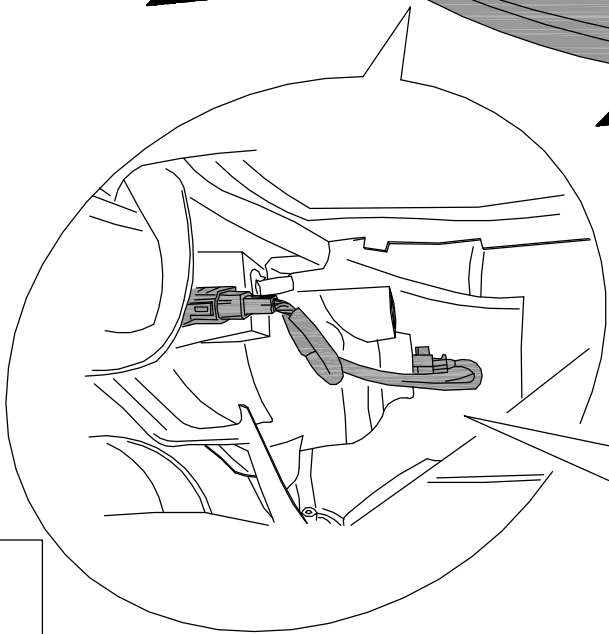
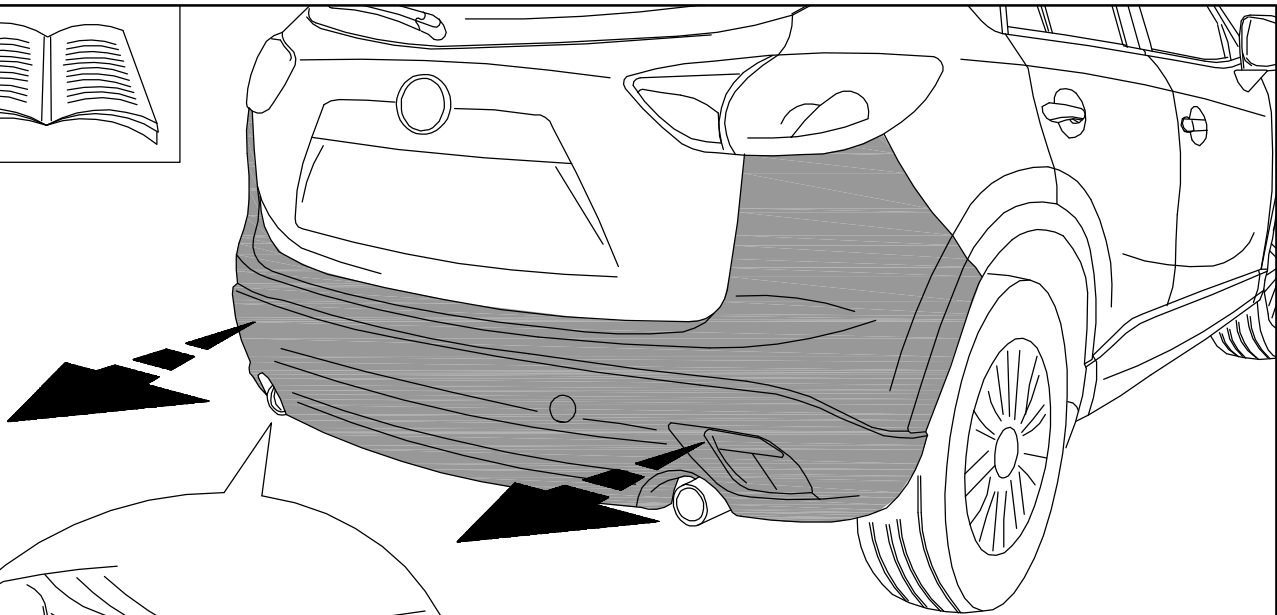
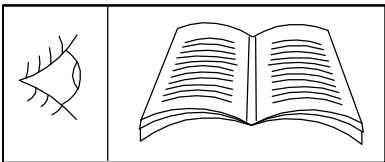

4

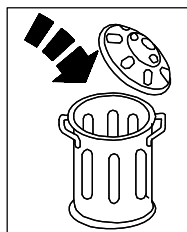
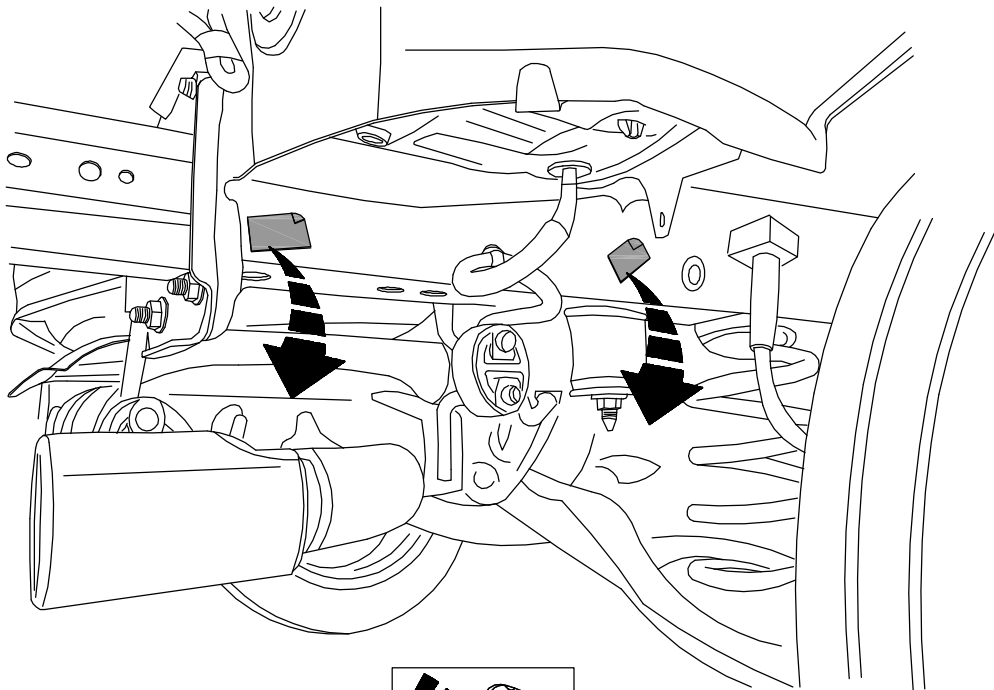
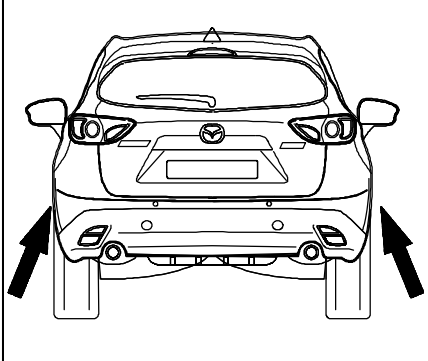

5

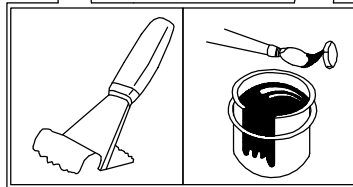
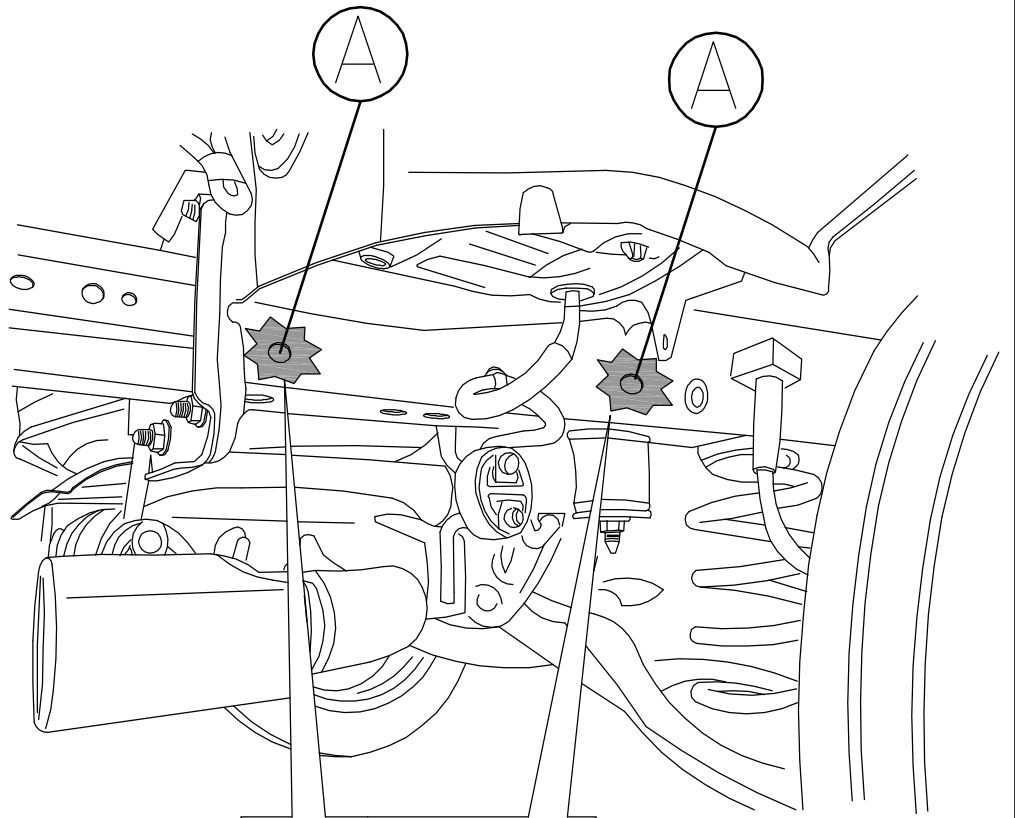
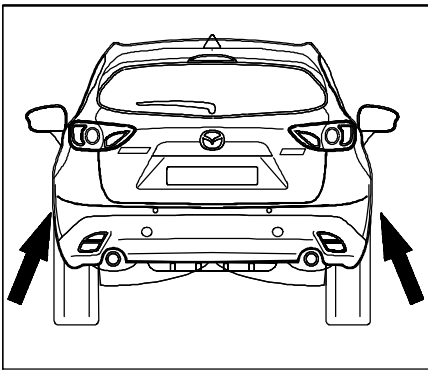

6

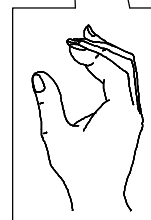
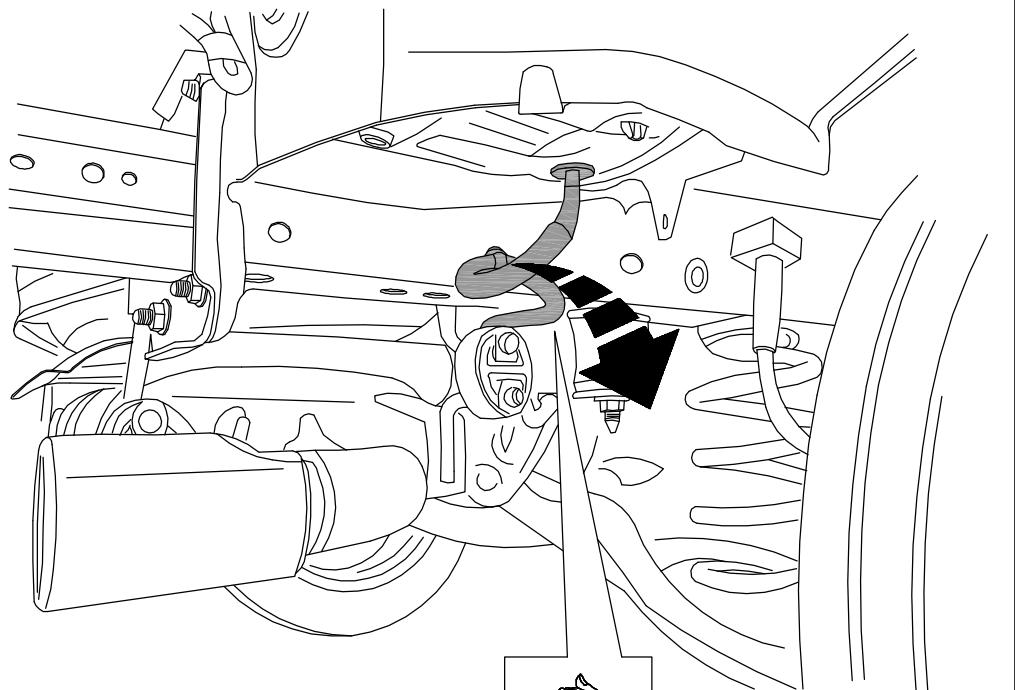
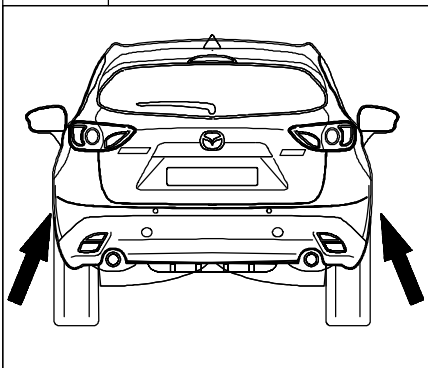

7

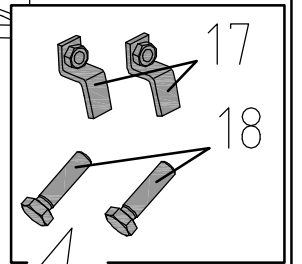
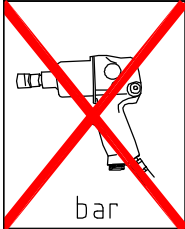
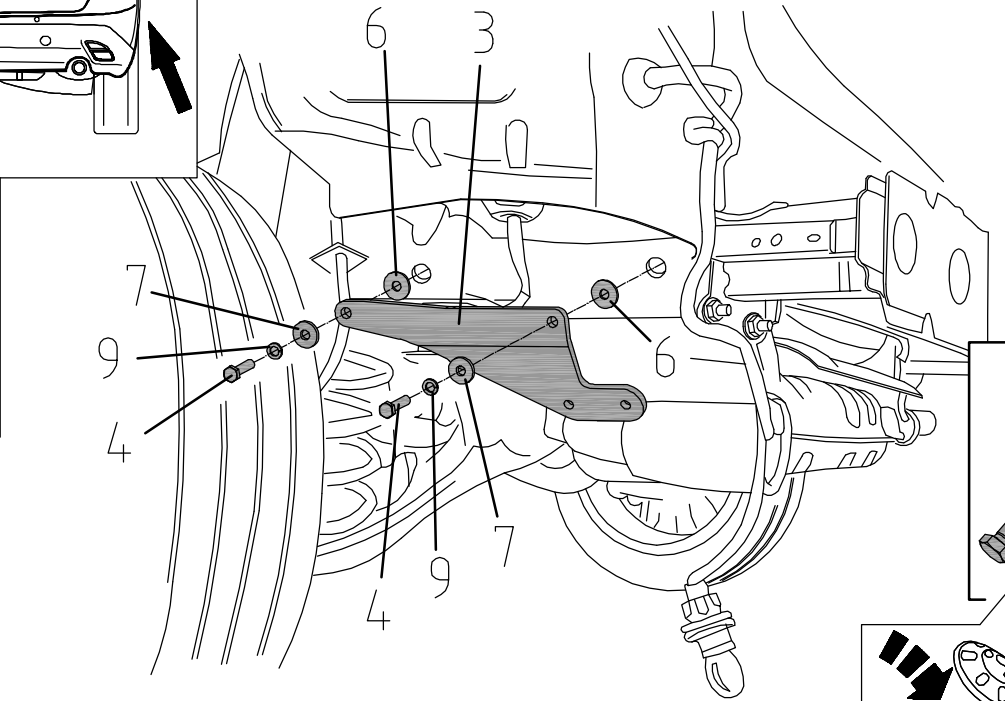
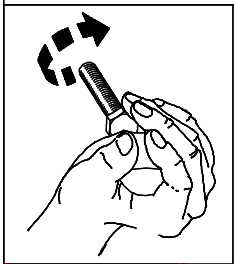
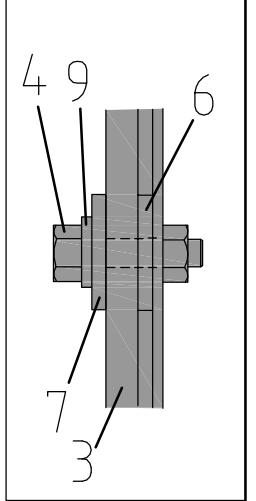
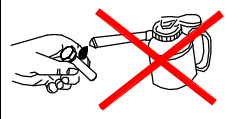
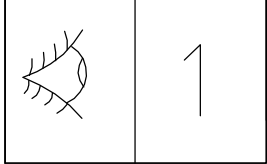
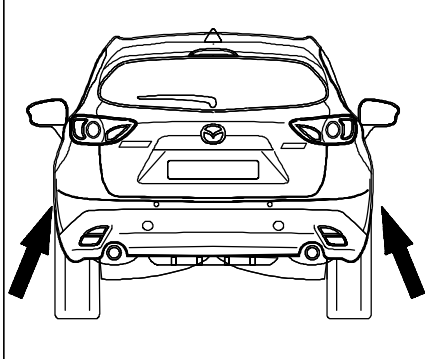
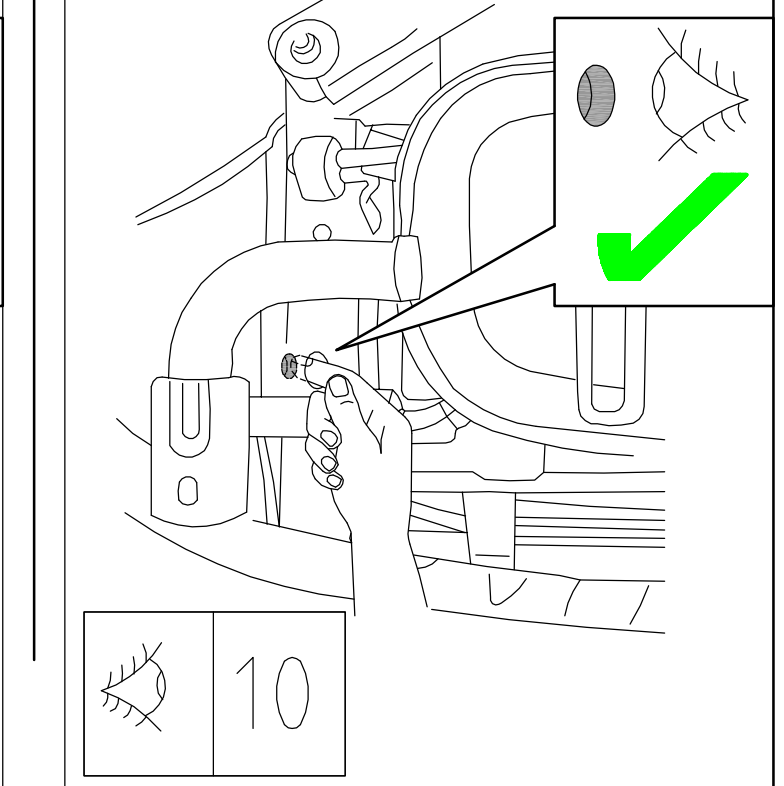
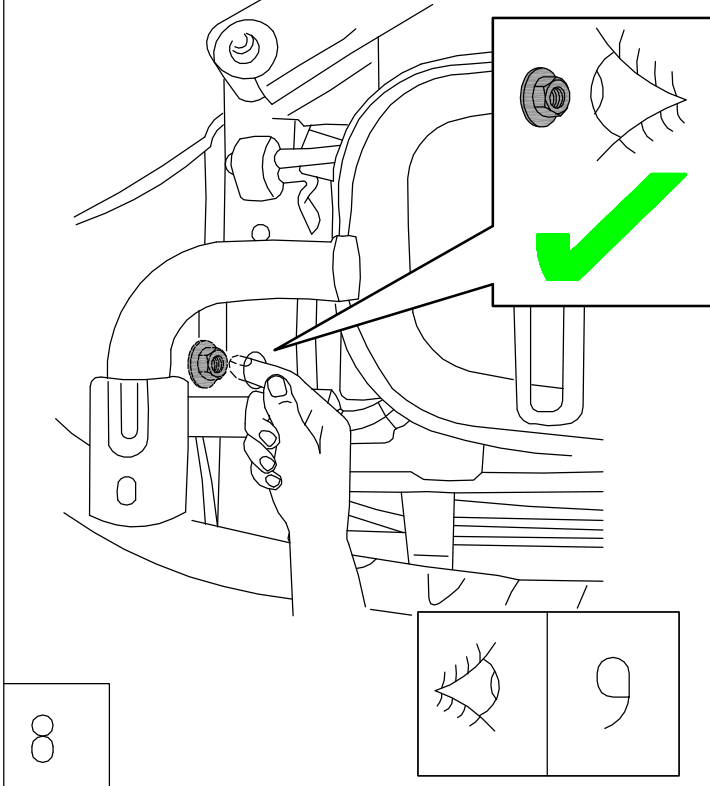
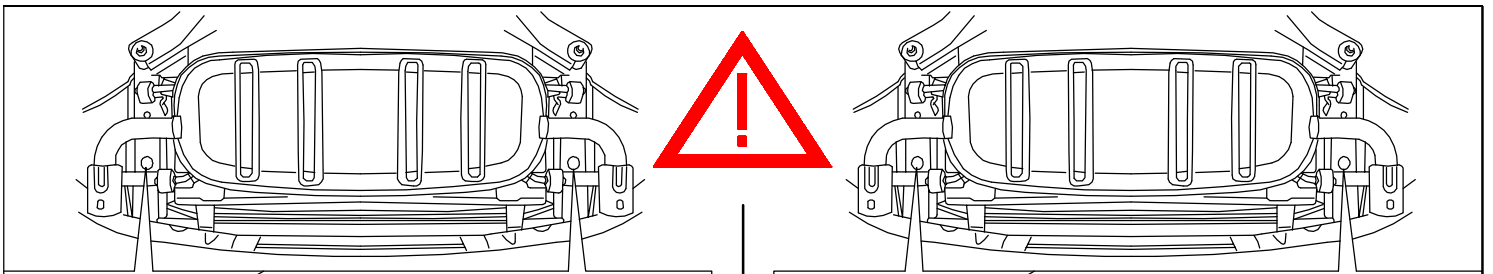

9

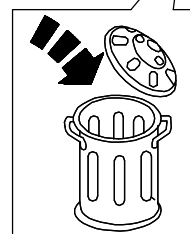

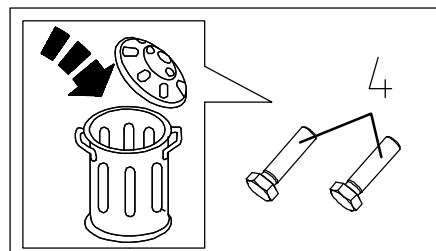
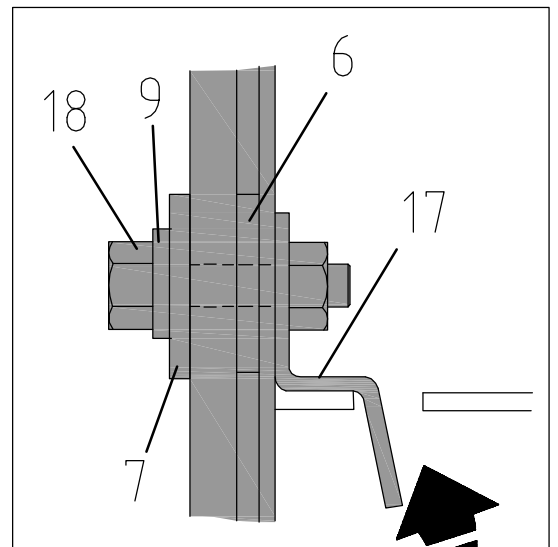
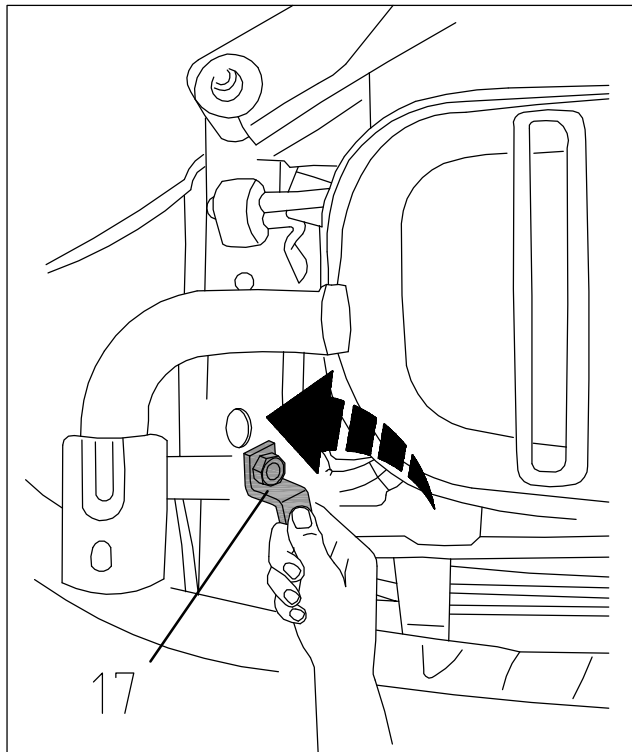
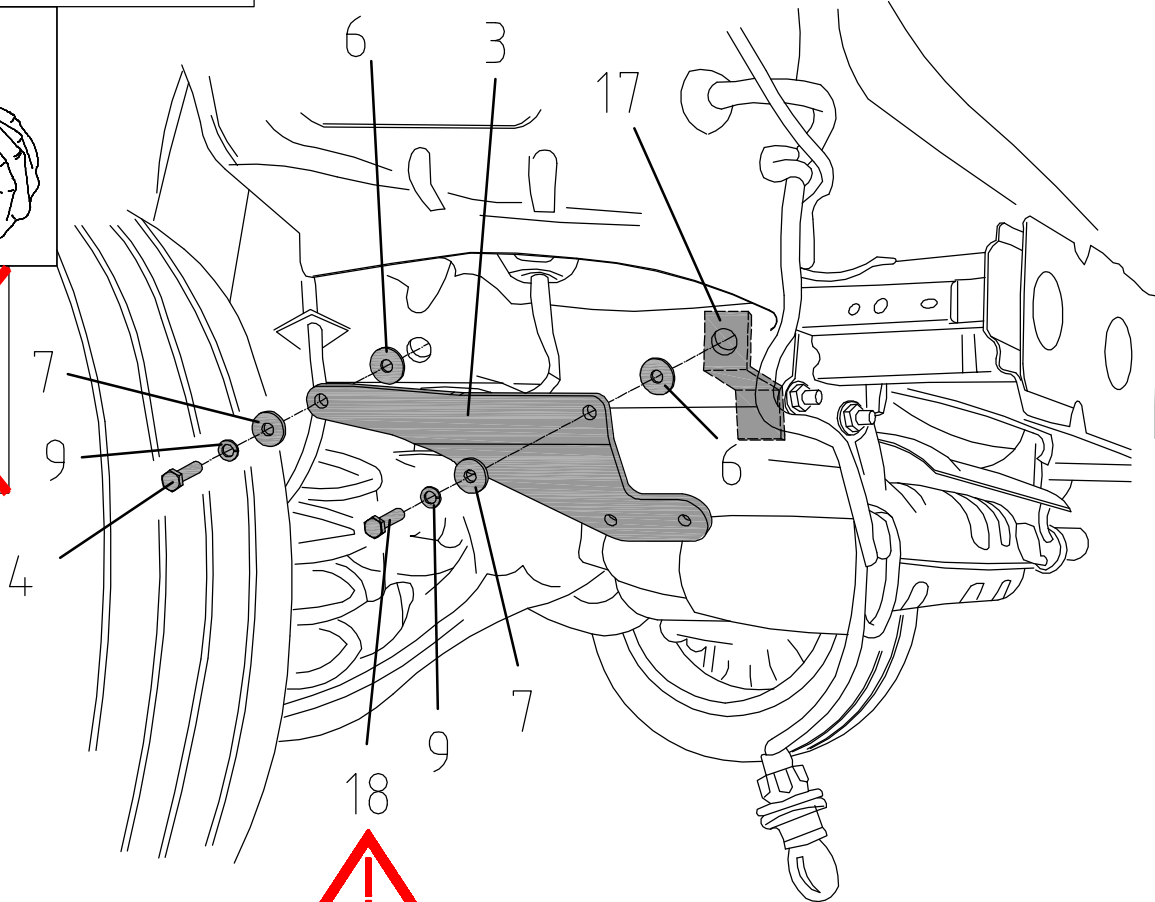
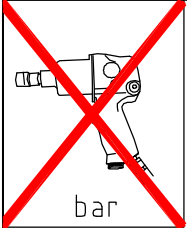
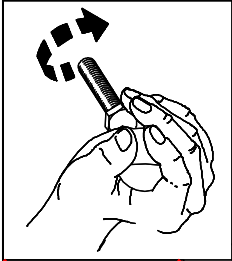
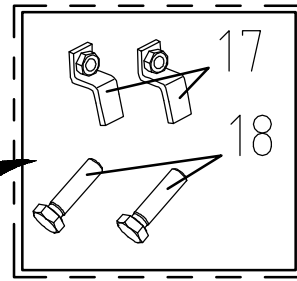
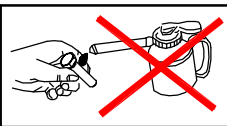
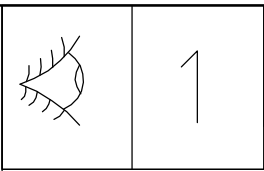
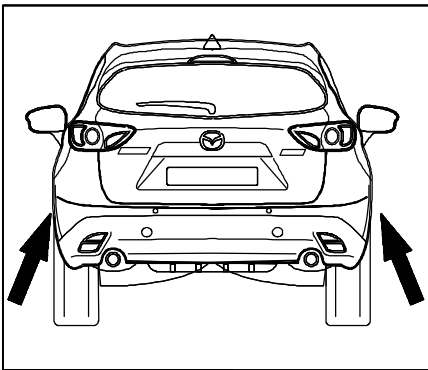

10

11-17

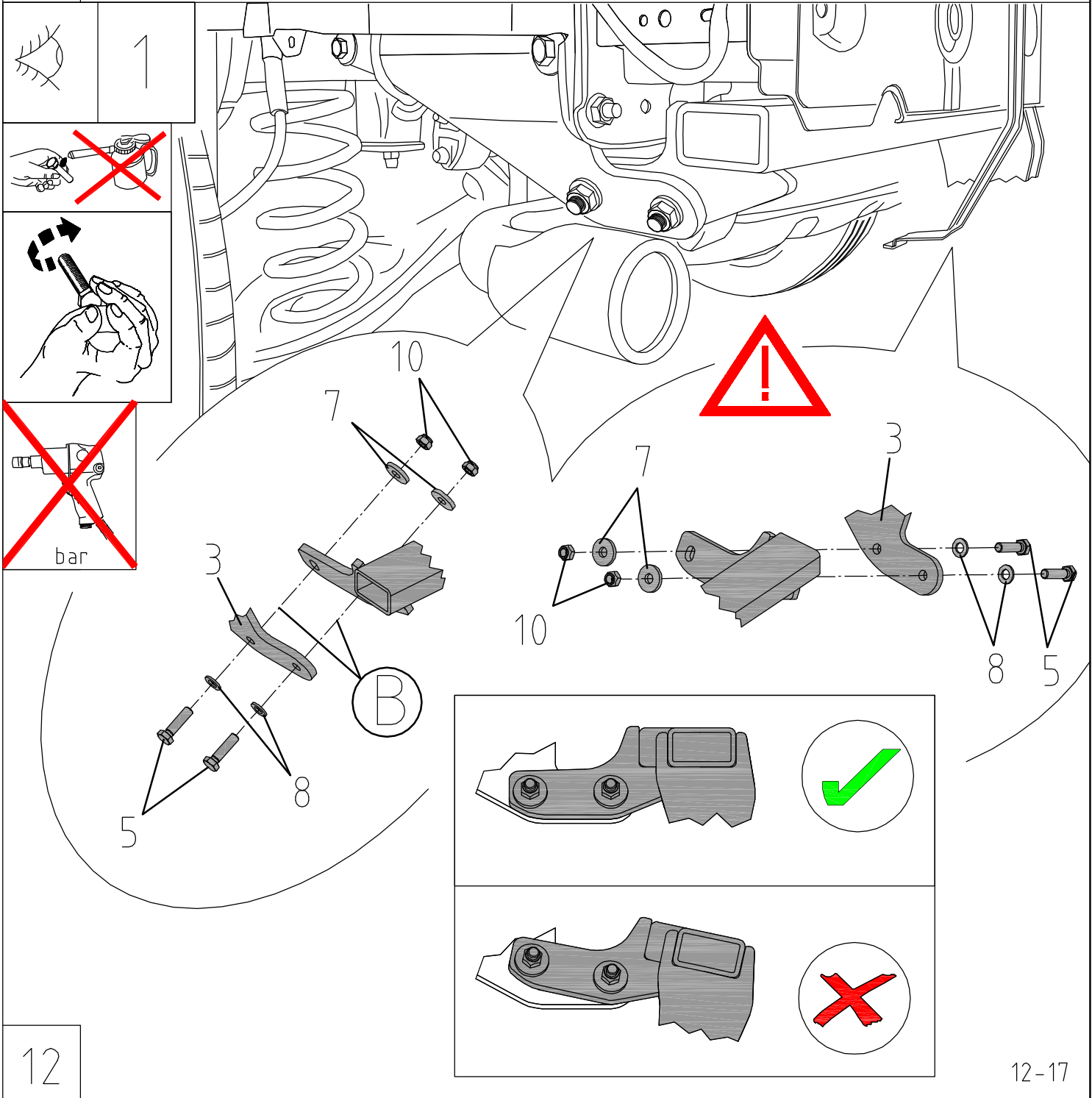
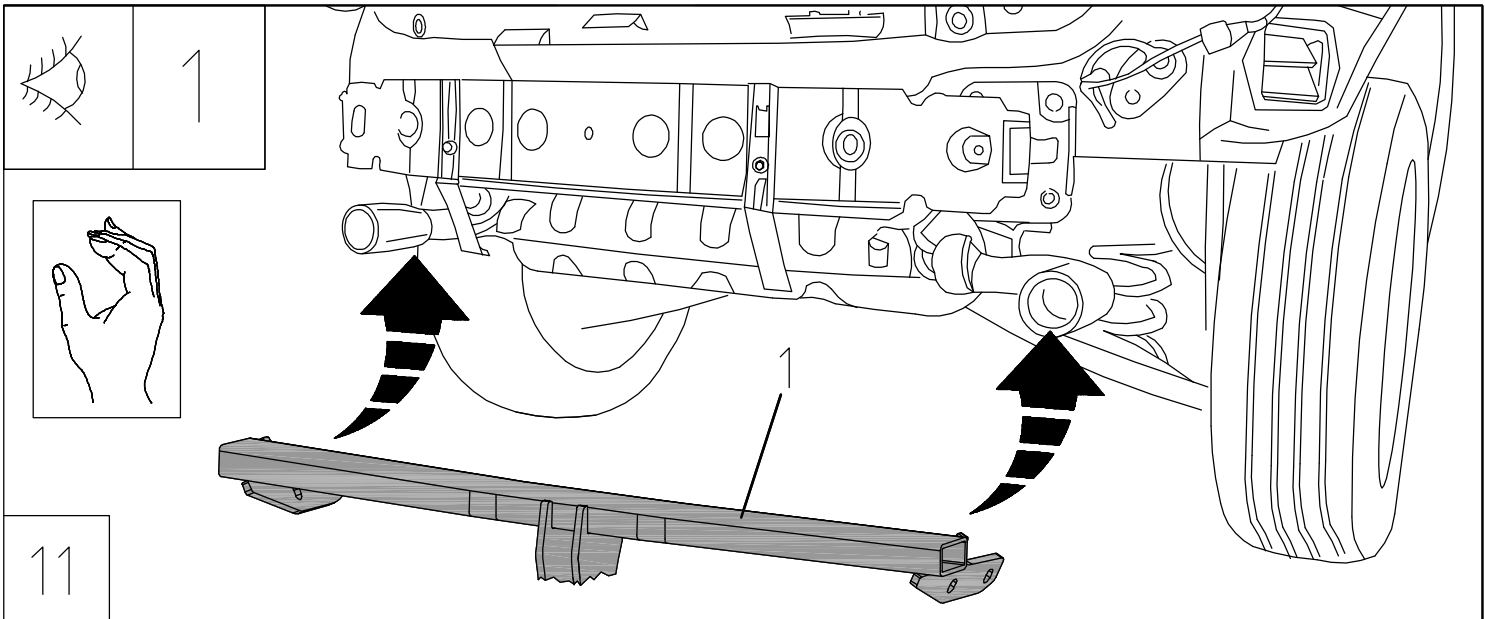

1

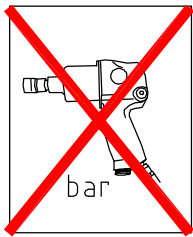
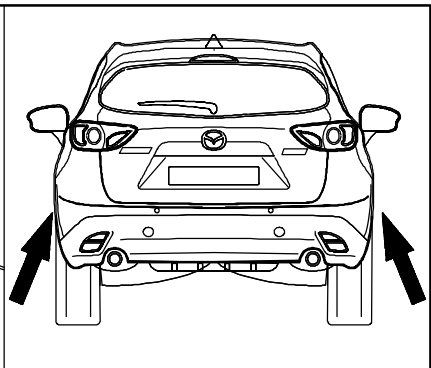
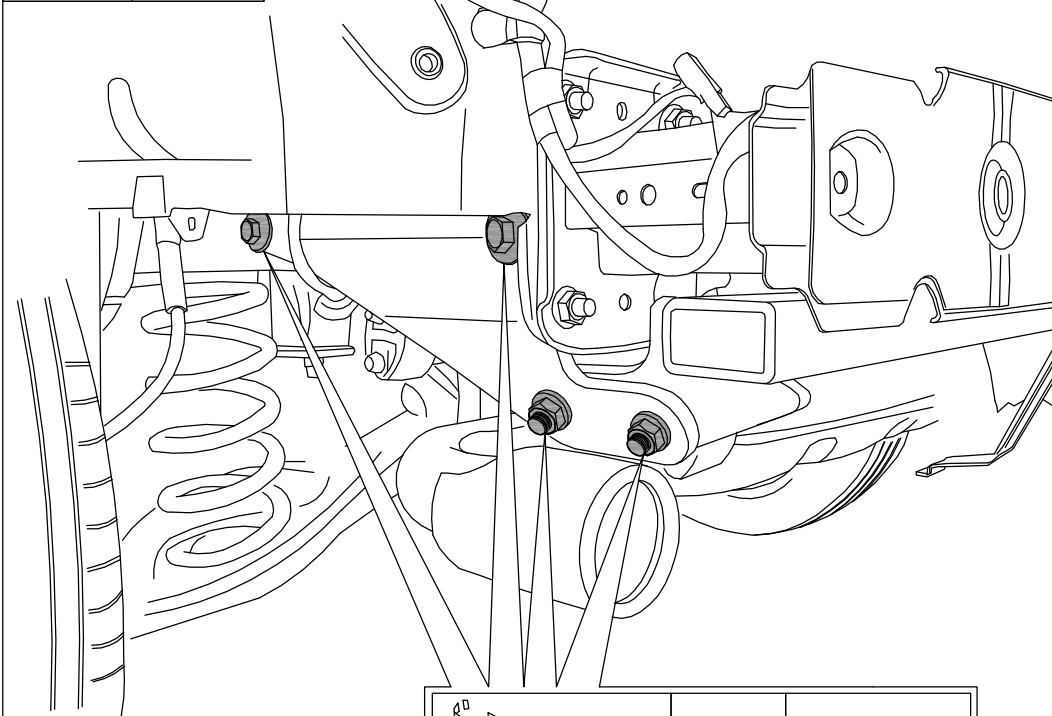

| | | | |
|--|------------|------------|-------------|
| | M12 | 8.8 | 68Nm |
|--|------------|------------|-------------|

13

1

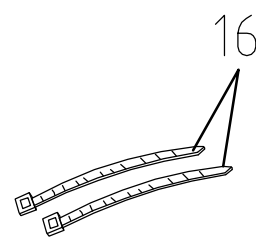
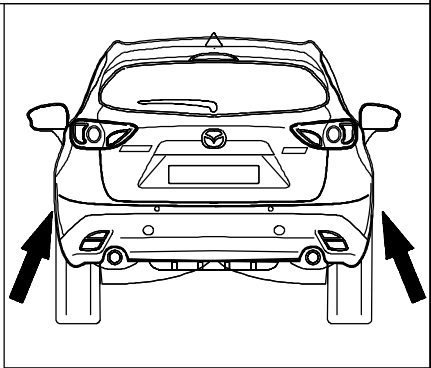
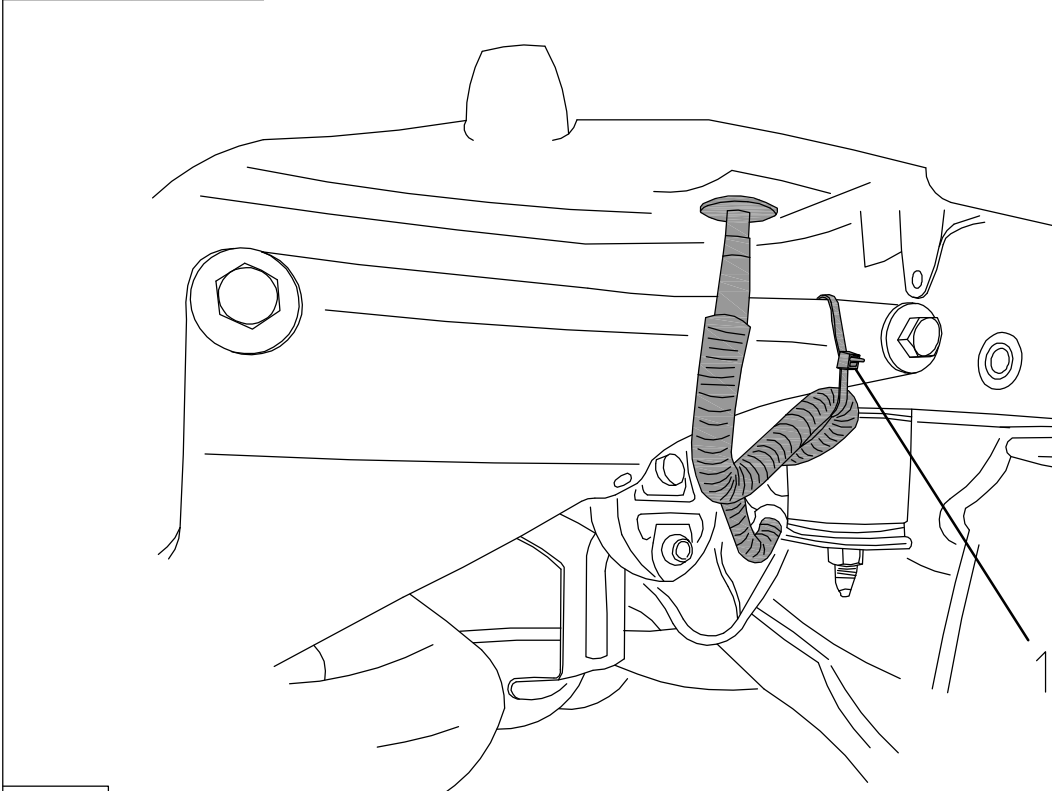

14

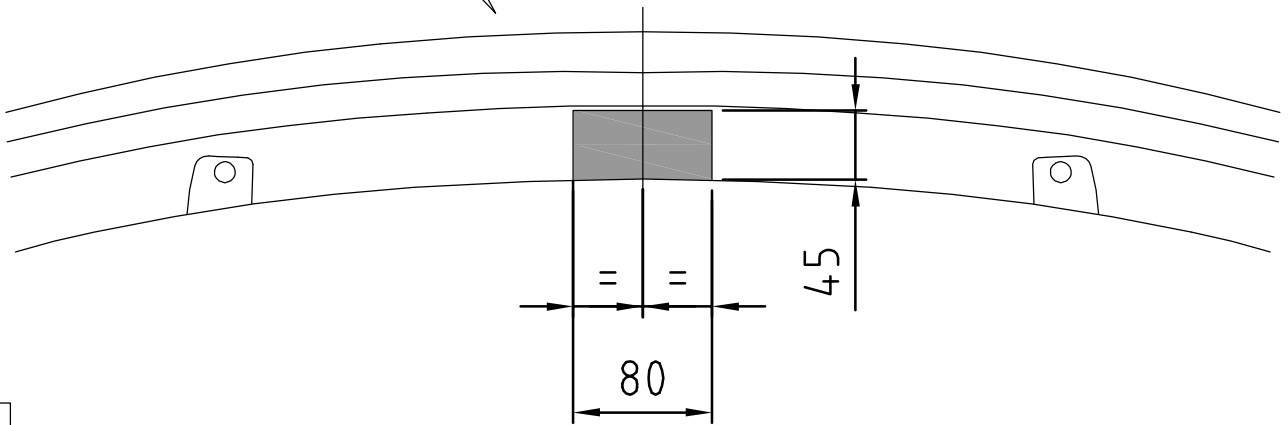
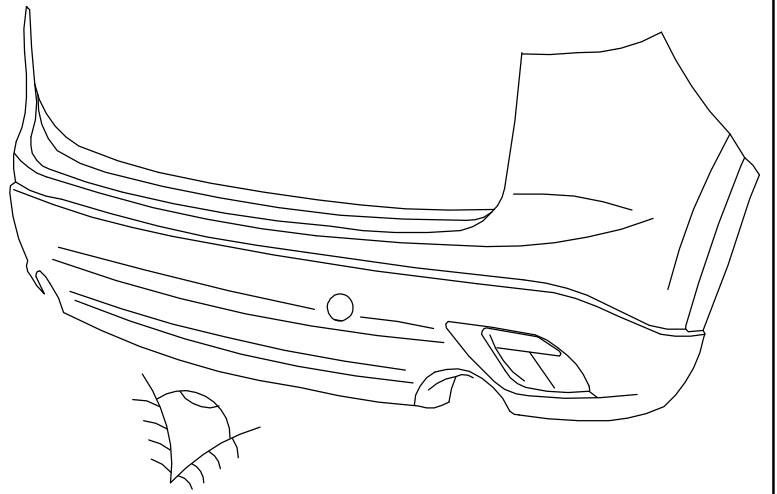
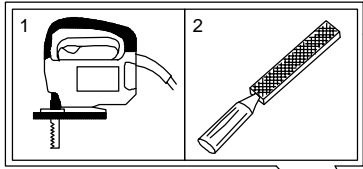

15

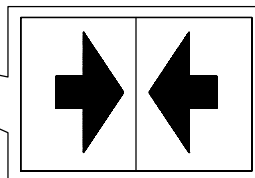
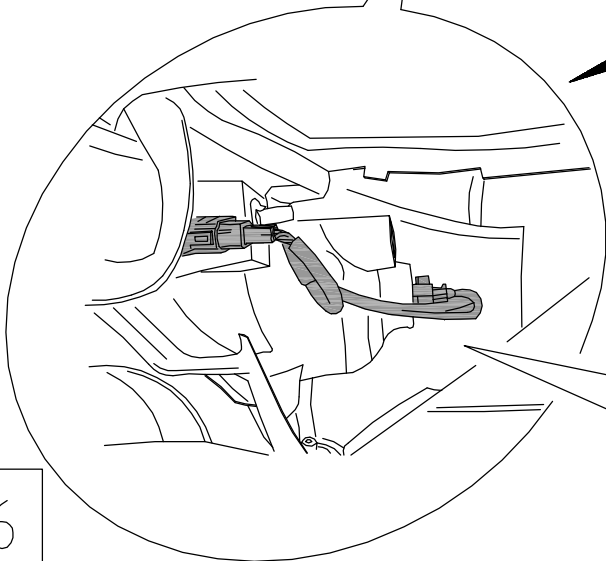
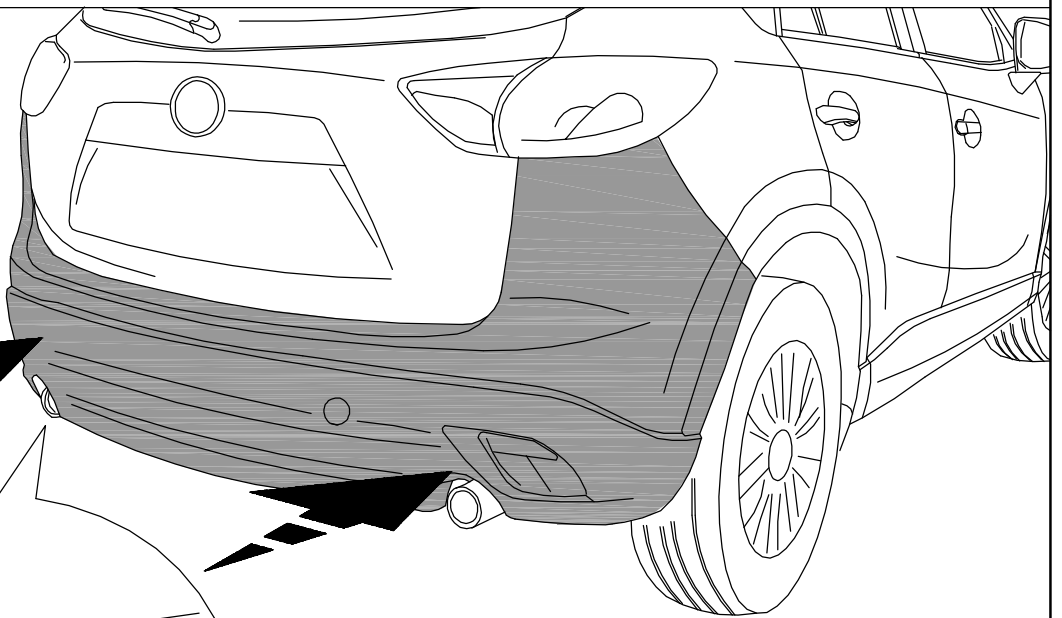
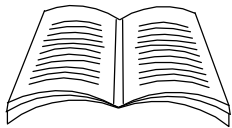

16

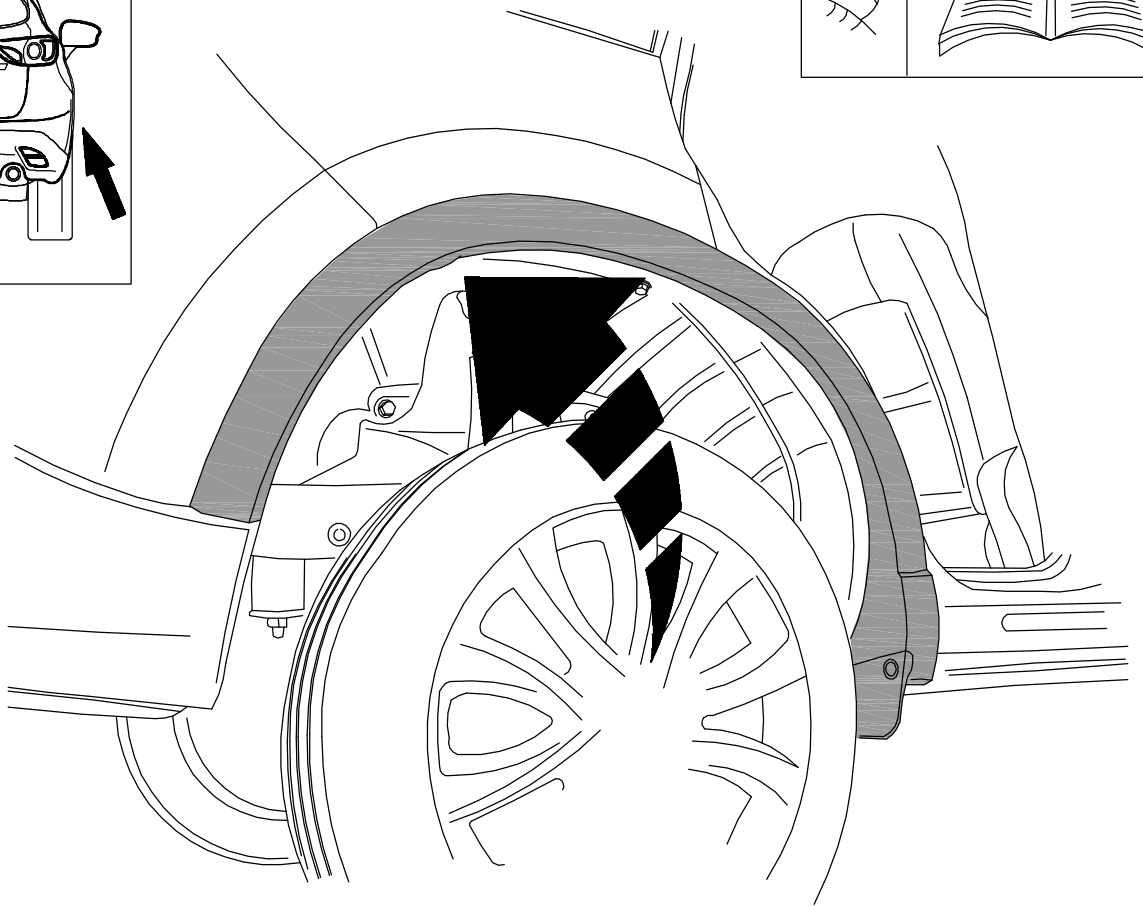
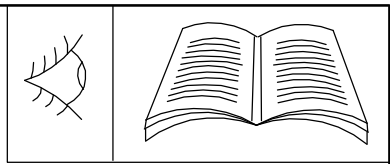
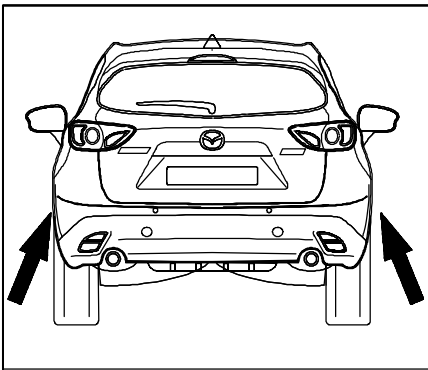

17

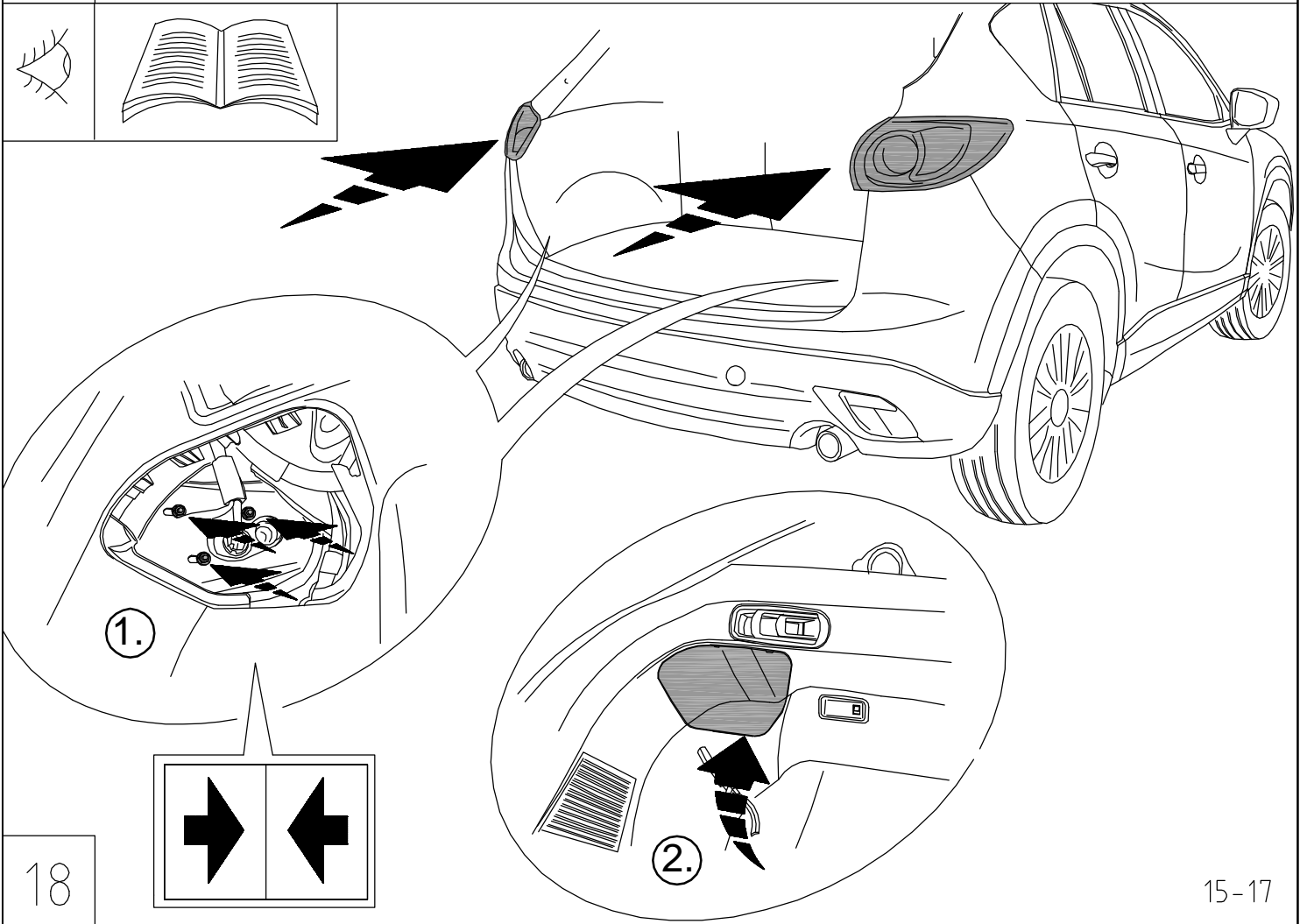
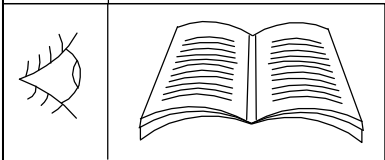

18

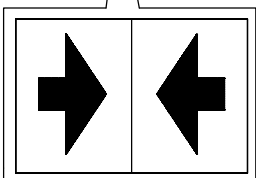

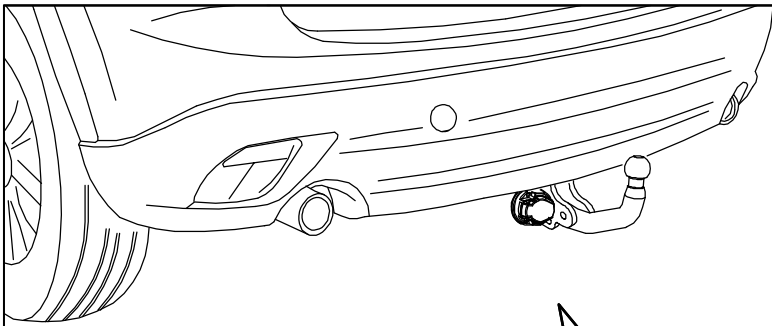

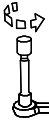
| | | | |
|--|-----|------|-------|
|  | M12 | 10.9 | 100Nm |
|--|-----|------|-------|

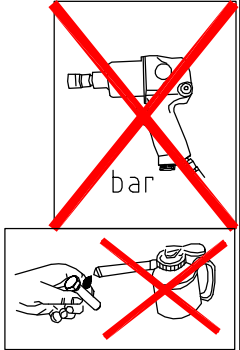
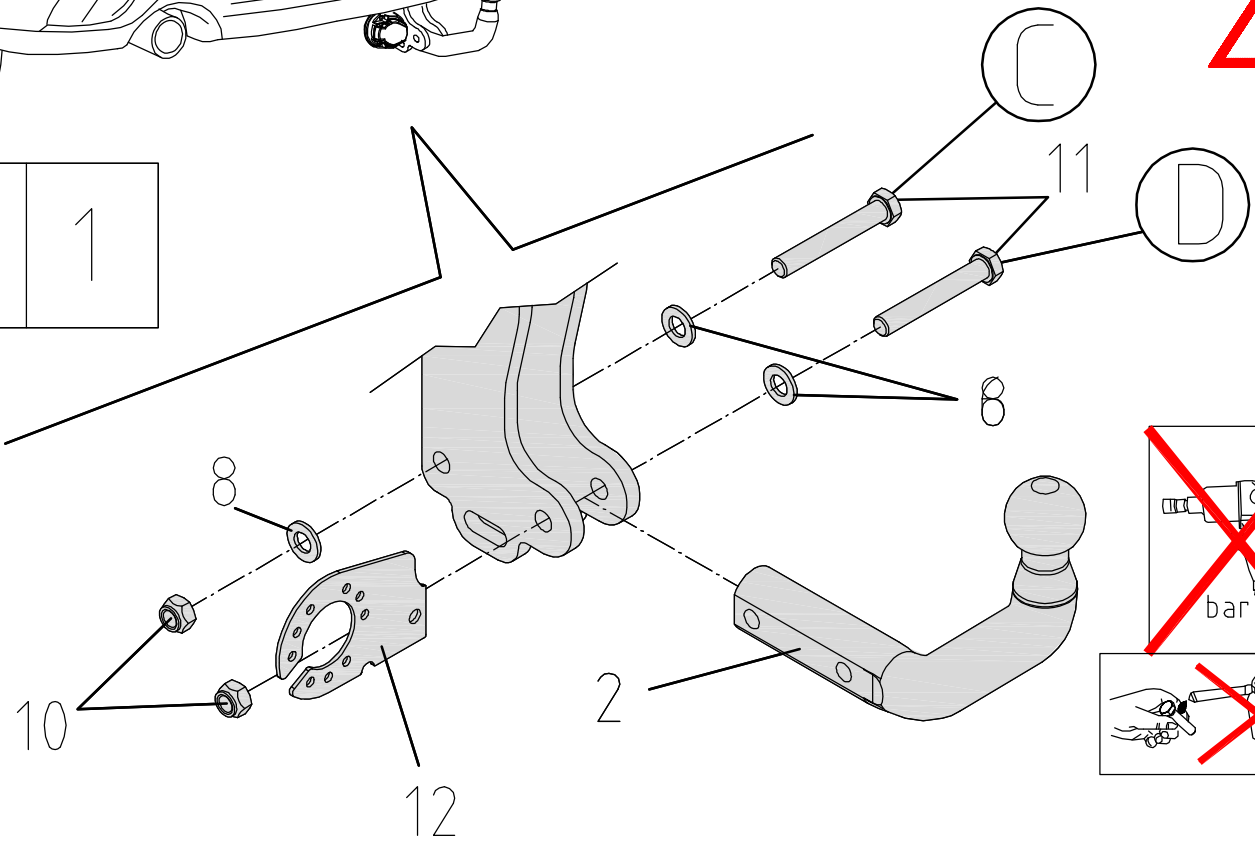
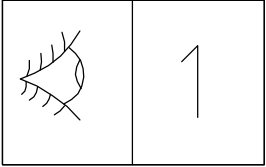

19

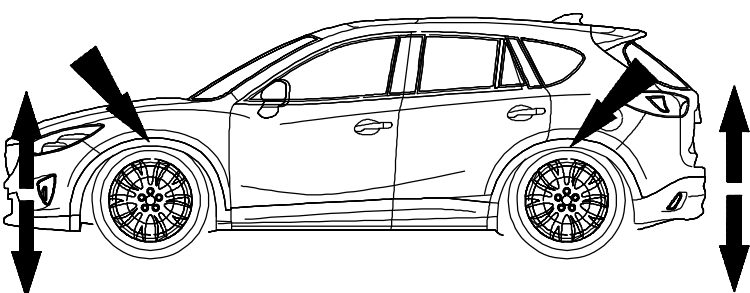
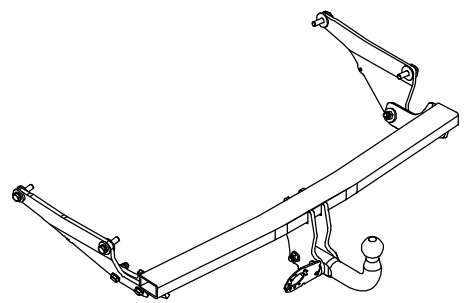
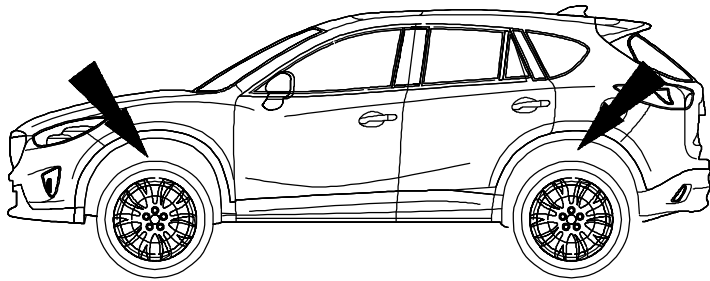

Best. Nr.: 0595 B

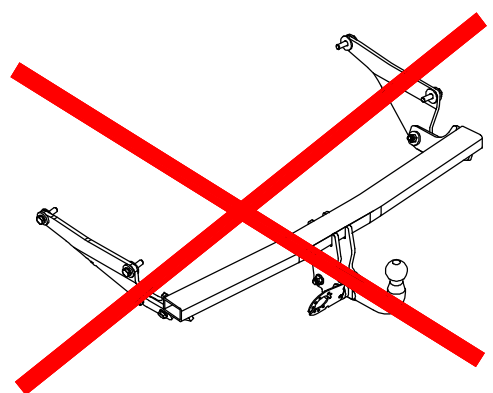

20 Technische Änderungen vorbehalten

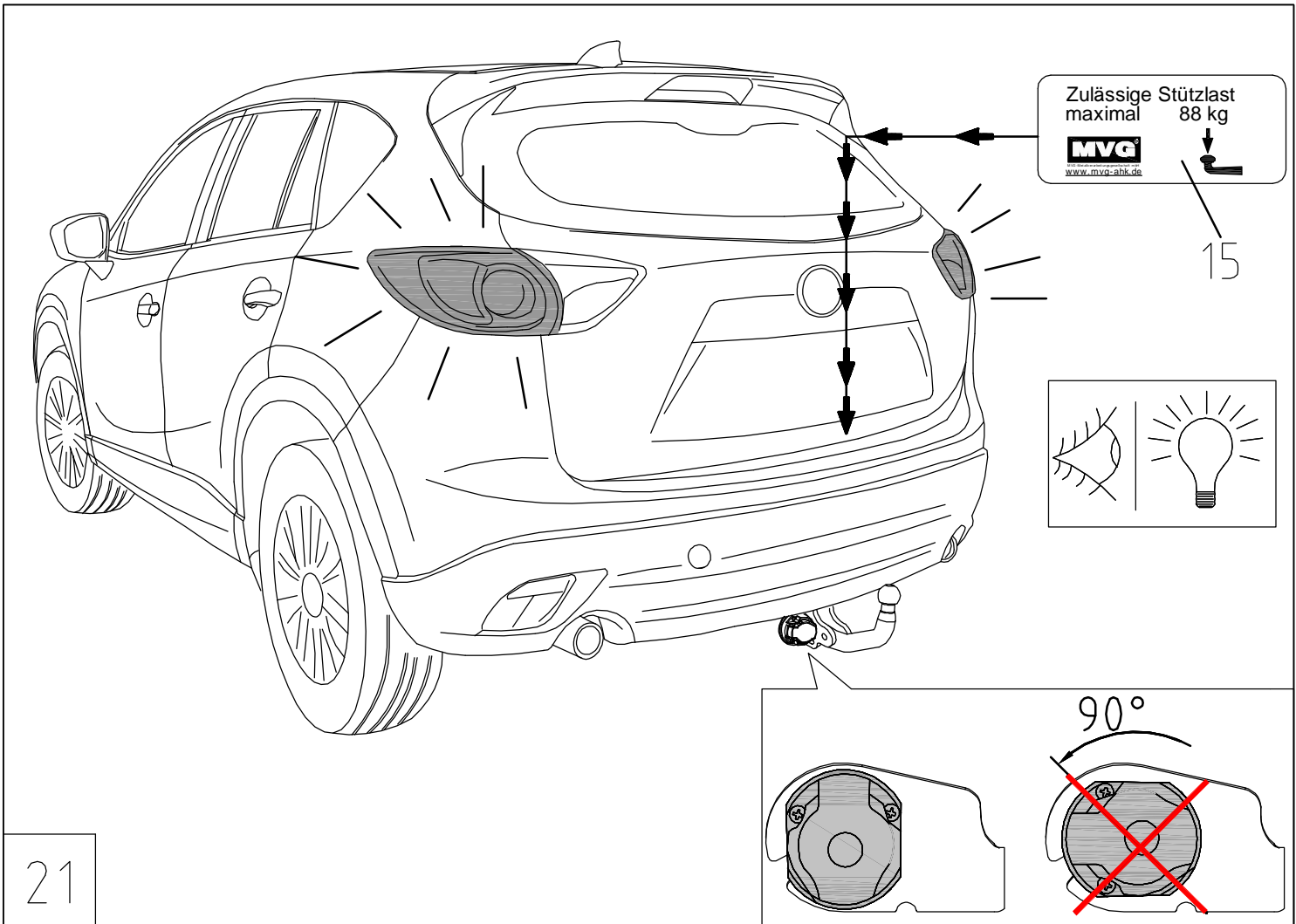

21

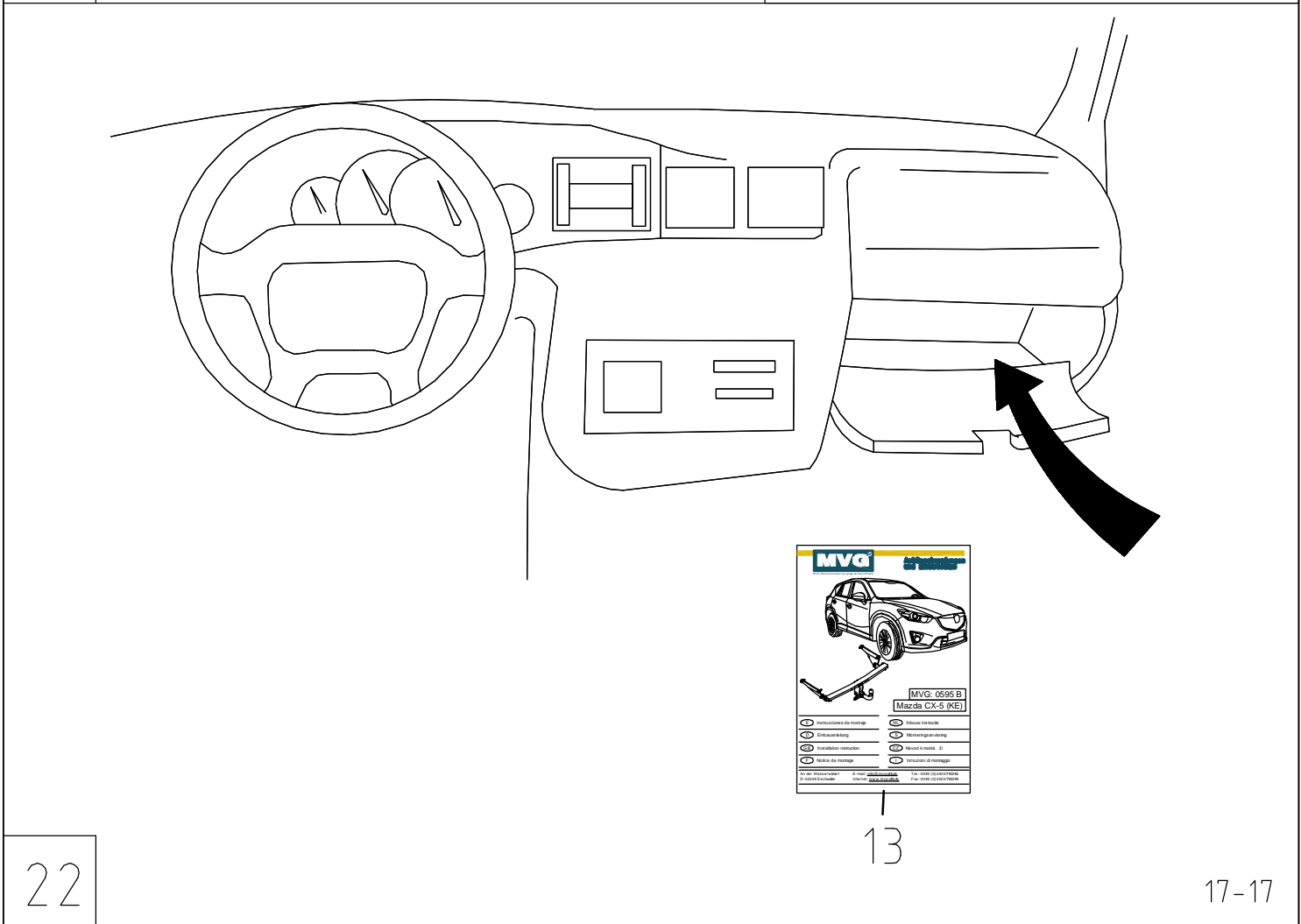

22