

Electric wiring kit for towbars / 13-pin / 12 Volt / ISO 11446

For use on: **MERCEDES BENZ E-Class**
W 210 Sedan from 05/95 to 02/02
S 210 T-model (station wagon) from 05/96
C 208 CLK Coupe from 06/97 to 03/02
C 208 CLK Convertible from 06/97

BRINK Part No. **727014**

General instructions for this electrical installation kit:

Before starting work always read the installation instructions completely. After installation of the electrical installation kit, give the installation instructions to the customer or owner of the vehicle for various operating information.

The electrical installation kit should be installed by a specialized workshop or qualified person. Improper use or modification of the electrical installation kit or parts thereof invalidates the guarantee.

- Before drilling any holes ensure that sufficient clearance is present.
- **When attaching the socket ensure that -**
The connection lines are not pinched.
The triple connection housing is properly installed on the microswitch!
The gasket at the line opening in the socket is properly seated on the insulating tubing.
- Route the wiring harnesses to prevent chafing. Ensure that sufficient clearance is present to sources of heat (e.g. exhaust system).
- **Check the installed electrical kit for proper function with a suitable tester or trailer.** Function testing is impossible with a tester without load resistors.
- When operating the vehicle with a trailer failure of a turn signal light on the trailer is indicated by the indicator light in the vehicle (turn signal indicator light) flashing at double the normal rate. An additional indicator light (C2) is not required when this electrical kit is used.
- The rear fog light is switched off on the towing vehicle by the microswitch integrated into the 7-pin socket immediately as soon as the trailer plug or an adapter is inserted. For this reason always remove any adapter used from the socket when the trailer is unhitched.

Kit includes:

1 Socket housing with microswitch	3 Screws M5 x 30
1 Wiring harness 12-conductor with preinstalled set of contacts, 13-pin	3 Nuts M5
1 Positive feed line, single conductor (red/blue)	3 Serrated washers
1 Fuse holder for 9 fuses	5 Cable straps 300 mm
1 Flat plug-in fuse 15A	15 Cable straps 100 mm

1. Disconnect vehicle battery

- **Ensure** that no saved data **is lost** when the vehicle battery is disconnected (e.g. in cockpit computer, immobilizer, radio, fault memory, etc.). **Observe vehicle manual and manufacturer's specifications.**
- Disconnect ground connection from vehicle battery. To prevent short circuits and for safety reasons it is only permissible to install the electrical installation kit with the vehicle battery disconnected.

2. Drill passage for wiring harness

W 210 Sedan / C 208 CLK Coupe & Convertible:

- Remove covering on trunk floor, vehicle jack and spare tire. Remove paneling rear end plate and left side paneling in trunk (on C 208 CLK Coupe/Convertible also on right).
- Drill **40 mm** dia. hole at suitable point on right in exhaust tunnel (see Fig. below). Deburr hole drilled, apply corrosion protection agent and allow to dry.

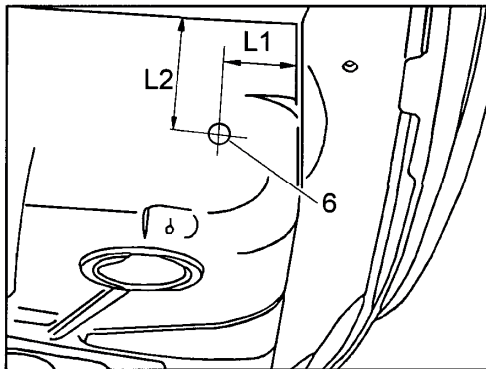

L1 = 85 mm from hole (6) to edge of spare tire recess

L2 = 130 mm from hole (6) to trunk floor

S 210 T-model (station wagon):

- Remove spare tire cover on left, vehicle jack and spare tire. Remove paneling on edge of trunk and trunk stowage compartment as well as left trunk side paneling.
- Remove cover on vehicle passage for 12-conductor wiring harness. (The passage is located at the bottom left in the trunk stowage compartment, see Fig. below) ream out passage on vehicle side to **40 mm** dia. deburr, treat with corrosion protection agent and allow to dry.

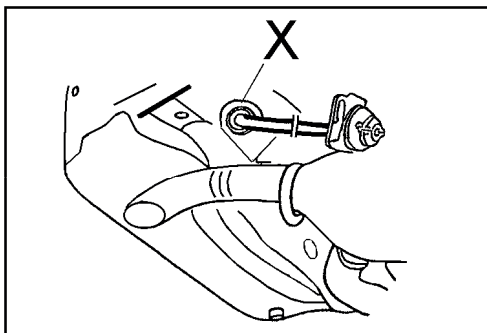

X = Passage on vehicle side

On vehicles with **Parktronic system (parking aid)** passage X already has a rubber grommet! In this case slit vehicle grommet sleeve and insert 12-conductor wiring harness through present grommet. Reinstall grommet and seal with sealant (e.g. Terrostat).

3. Installing 12-conductor wiring harness and socket

- Remove rear seat and detach footwell paneling below instrument panel on driver's side. Open vehicle cable duct along left side of vehicle.
- Route end of 12-conductor wiring harness with preinstalled 13-pin contact insert through passage described in Point 2 (depending on specific model) through trunk to outside and then on from rear through hole in socket mounting plate for trailer hitch.
- Insert preassembled 13-pin contact insert into enclosed socket housing and snap in place. Attach triple socket housing for 12-conductor wiring harness to microswitch positioned at bottom in socket housing (ensure that it is seated correctly!)
- Push rubber grommet onto socket and fasten socket to trailer hitch socket mounting plate with enclosed bolts, serrated washers and nuts.

- Position passage grommet mounted on wiring harness and insert into passage hole in trunk.

The socket is coded as follows:

Wire	Contact No.	Function
Black/white	1	Left turn signal
Gray	2	Rear fog light on trailer
Brown	3	Ground (for Contact No. 1 to 8)
Black/green	4	Right turn signal
Grey/red	5	Right taillight
Black/red	6	Brake light
Gray/black	7	Left taillight
Blue/red	8	Back-up light
Red/blue	9	Power supply (continuous positive)
Not used	10	Positive charging lead for battery in trailer
Not used	11	Ground (for Contact No. 10)
Not used	12	Trailer recognition control lead
Brown	13	Ground (for Contact No. 9)

- Route 12-conductor wiring harness to left side of trunk and connect end terminal on **brown** leads to ground point on vehicle side in area of left taillight. (See Fig. on Page 5, **Pos. 1**)

W210 Sedan /S 210 T-model (station wagon):

- Route remaining ends of wiring harness along vehicle wiring harness to B-pillar.
- Route ends of wiring harness with **brown/white** and **red/blue** leads to pneumatic control unit (PSE) or to fuse box on right below rear seat. (See Fig. on Page 5, **Pos. 2 & 3**)

C 208 CLK Coupe and CLK Convertible:

- Route ends of wiring harness with **brown/white** and **red/blue** leads along front wall of trunk to right side of trunk. (If necessary slightly remove adhesive fabric tape wound around 12-conductor wiring harness to obtain a sufficient length of wire or more exact tie-out in trunk!)
- Route contact sleeve on **brown/white** lead along vehicle wiring harness to pneumatic control unit (**PSE**) on right side of trunk (between wheelhouse and taillight).

CLK Coupe only:

- Route contact spring on red/blue lead to fuse box next to vehicle battery at right rear in trunk. The assigned plug-in location for the contact spring and the flat plug-in fuse is given in the assignment chart for the fuse box in the vehicle manual!

CLK Convertible only:

- Cut through the **red/blue** lead at the above tie-out on the left side of the vehicle if the **continuous power** (B+ / Terminal 30) is desired in the trailer socket.
- Extend the **red/blue** lead with a suitable lead connector of the same color and cross-section {2.5 mm²} as required and route along the left side of the vehicle through the guide grommet in the splash wall (behind the light module) to **fuse box F1** in the engine compartment. Remove fuse holder from fuse box and insert the lead here at **fuse plug-in location 18B**.

C 208 CLK Coupe and CLK Convertible:

- Route remaining ends of wiring harness along vehicle wiring harness to left B-pillar.

W210 Sedan and S 210 T-model (station wagon) up to 03/97:

- Remove foam rubber jacket from pneumatic control unit (**PSE**), pull **12-pin plug housing** off of pneumatic control unit and remove locking strap with plug housing covering.

- Insert contact sleeve on **brown/white** lead in wiring harness into free **chamber No. 2** in **12 pin plug housing** and snap in place. Continue to reassemble 12-pin plug housing and pneumatic control unit (PSE) in opposite order.

W / S 210 and C 208 – All models as of 03/97:

- Remove foam rubber jacket from pneumatic control unit (**PSE**), pull **18-pin plug housing (white)** off of pneumatic control unit and remove locking strap with plug housing covering.
- Insert contact sleeve on **brown/white** lead in wiring harness into free **chamber No. 15** in **18 pin plug housing (white)** and snap in place. Continue to reassemble 18-pin plug housing and pneumatic control unit (PSE) in opposite order.

NOTE: *If chambers No. 2 and/or 15 (depending on model) are already in use, solder the **brown/white** lead from the 12-conductor wiring harness into the brown/white wire loop present on the vehicle and insulate.*

W210 Sedan and S 210 T-model (station wagon):

- Route **red/blue** lead to fuse box. Remove vehicle fuse holder for 9 fuses from fuse box and open secondary lock (red) on **plug-in location 12** by sliding to side.
- Insert the contact spring on the **red/blue** lead into the free chamber for **plug-in location 12** from below and snap in place, **reclose secondary lock**.
- Reinstall fuse holder for 9 fuses in fuse box and insert enclosed flat plug-in fuse (15A) into **plug-in location 12** in fuse holder.

NOTE: *The enclosed fuse holder for 9 fuses and the **red/blue** positive lead are not required in this case!! The fuse holder for 9 fuses is not present on some equipment versions. In such cases it is necessary to install the enclosed fuse holder for 9 fused with enclosed **red/blue** positive lead (connect positive pole of vehicle battery to plug-in location 12 on fuse holder)!!*

W210 Sedan and S 210 T-model (station wagon) up to 03/97:

- Strip insulation off of junction points on **black/white** and **black/green** vehicle leads (left and right turn signal functions) in cable duct behind B-pillar. (See Fig. on Page 5, **Pos. 4**)
- Solder the loose, tinned ends of the **black/white** and **black/green** leads from the 12-conductor wiring harness to the junction points on the vehicle leads of the same color and insulate soldered points.

W / S 210 and C 208 – All models as of 03/97:

- Solder the loose, tinned ends of the **black/white** and **black/green** leads from the 12-conductor wiring harness to the junction points on the vehicle leads of the same color for the left and right turn signal functions (in area of driver's seat in front of B-pillar) and insulate soldered points.

W / S 210 and C 208 – All models:

- Cut through **gray/green** vehicle leads (rear fog light function) in cable duct at B-pillar (see Fig. on Page 5, **Pos. 5**); strip approx. 8 mm of insulation from ends of leads and tin.

NOTE: *Cut through the vehicle lead coming from the light module or rear fog light switch and leading to the rear fog light!!*

- Solder the tinned ends of the leads to the 12-conductor wiring harness as follows:

Solder the **gray/green** lead coming from the light module or rear fog light switch to the gray lead in the 12-conductor wiring harness. Insulate soldered point carefully.

Solder the **gray/green** vehicle lead leading to the rear fog light switch to the gray/green lead in the 12-conductor wiring harness. Insulate soldered point carefully.

- Route the remaining ends of the wiring harness with the 10-pin plug housing in the cable duct on the left side of the vehicle to the footwell on the driver's side.
- Insert 10-pin plug housing into free plug-in location in light module (on rear of light switch) and snap in place. (See Fig. below, **Pos. 6**)

Vehicles with Parktronic System (parking aid):

- A lead with loose end (lead color **brown/white**) is present in the cable duct on the left side in the area of the B-pillar (see Fig. on Page 5, **Pos. 5**) Strip approx. 8 mm of insulation off of the end of this lead and tin.
- Cut through the **brown/white** lead loop in the 12-conductor wiring harness running in the area of the B-pillar. Strip approx. 8 mm of insulation off the ends of the lead and solder to the end of the (**brown/white**) lead on the vehicle side. Insulate soldered point carefully.

NOTE: On **C 208 CLK Coupe** and **CLK Convertible** the loose ends of the leads are located on the **right side** in the cable duct at the B-pillar. Extend these leads and solder to the **brown/white** lead in the 12-conductor wiring harness in the trunk in the area of the pneumatic control unit (**PSE**). Insulate soldered points carefully.

Line route and connection points for trailer socket wiring harness

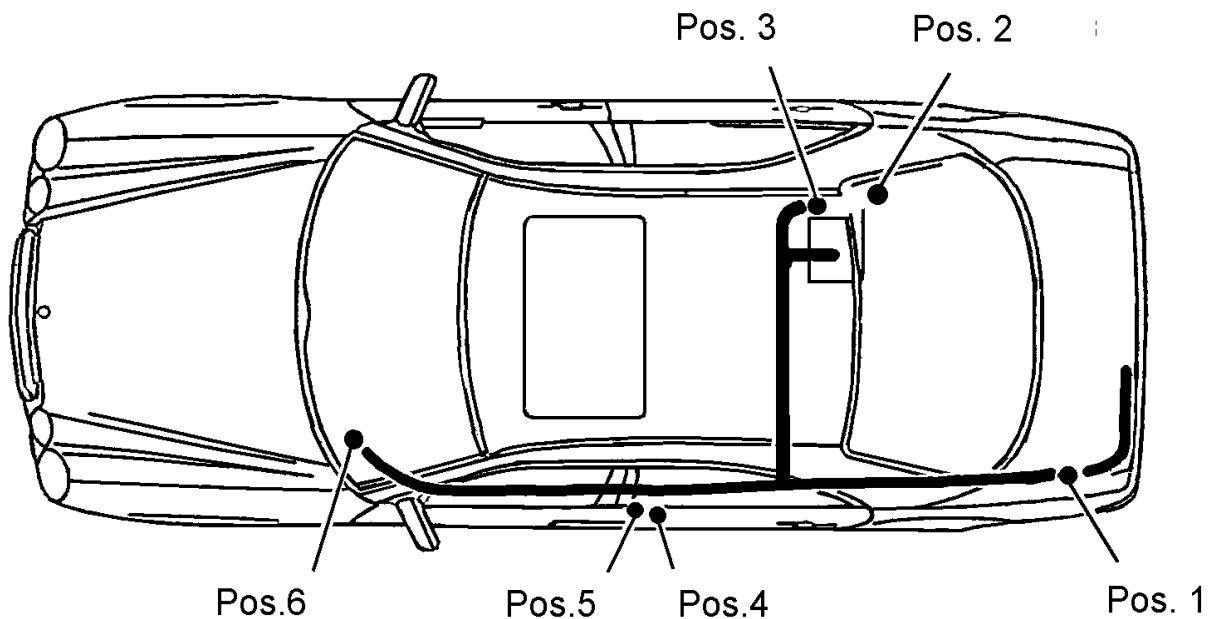

The routing of the wiring harness shown above is identical on the W 210 Sedan and S 210 T-model (station wagon)!

4. Function check and final installation

- Reconnect vehicle battery.
Check the individual functions in the socket and the electrical kit as well as the functions of the vehicle lighting.
- Fasten all lines in the installation kit – use cable holders present or enclosed cable straps.
Reinstall all paneling and other parts removed.