



Certified Automotive Parts Association

Vehicle Test Fit Report

Report Number: JPGC99FR1/RDM VTF

Gordon Auto Body Parts Co., Ltd.

CAPA Part Number: JPGC99FR1

**Random (RDM)
Vehicle Test Fit (VTF)**



Date Performed: 10 November 2004

Performed by



This report shall not be reproduced except in full without the written approval of the testing laboratory.

Random (RDM) Vehicle Test Fit (VTF) Summary Page

Report Number:	JPGC99FR1/RDM VTF	
Prepared By:	_____ HL	
Tested By:	_____ Scott Jenkins (Printed Name)	_____  (Signature)
Witnessed By:	_____ N/A	
Approved By:	_____ Brian Slagel (Printed Name)	_____  (Signature)
Date of Issue:	_____ 12 November 2004	

Testing Laboratory Name and Address:	Intertek ETL Entela 3033 Madison Avenue SE Grand Rapids, MI 49548 USA
Testing Location:	3542 Roger B. Chaffee SE Grand Rapids, MI 49548 USA

Applicant's Name and Address:	Gordon Auto Body Parts Co., Ltd. No. 48, Nie-Shi Road Lu Chu Hsiang, Taoyuan County, 338 Taiwan, R.O.C.
--------------------------------------	--

Test Specification Standard:	CAPA QSM
Test Procedure:	TVOP-004, Performing a Random VTF
Test Report Form No.:	VTF.007F
TRF Originator:	Intertek ETL Entela
Master TRF:	31 December 2000

Random (RDM) Vehicle Test Fit (VTF) Summary Page

Report Number: JPGC99FR1/RDM VTF

TEST ITEM DESCRIPTION:

CAPA Part Number: JPGC99FR1
CAPA Lot Number: 01/04A
CAPA Seal Number: 32957123
Car Company Service (CCS) Part Number: 55135900AC
Part Type: RH Fender
Part Application: Jeep Grand Cherokee 1999 – 04
Vehicle Used: Jeep Grand Cherokee 2000

Date Part Received: 10 November 2004

Testing Date: 10 November 2004

CONCLUSION:

Status of Part Certification: **Remain Certified** **Decertified**

Status of Lot Certification 01/04A: **Certified** **Decertified**

Test Fit Result: **Pass** **Fail**

Fit: **Pass** **Fail**

Appearance: **Pass** **Fail**

Note: No CAPA or CCS parts will be returned to the manufacturer until further notice from the manufacturer.

Note: Since the CAPA part passed the VTF; it was unnecessary to install the CCS part.

Date: 10 November 2004
CAPA Part #: JPGC99FR1
Car Company: Jeep Grand Cherokee
Service (CCS) Part #: 55135900AC

Report Number: JPGC99FR1/RDM VTF
Manufacturer: Gordon
Part Application: 1999-04

Vehicle Test Fit Dimensional Diagram

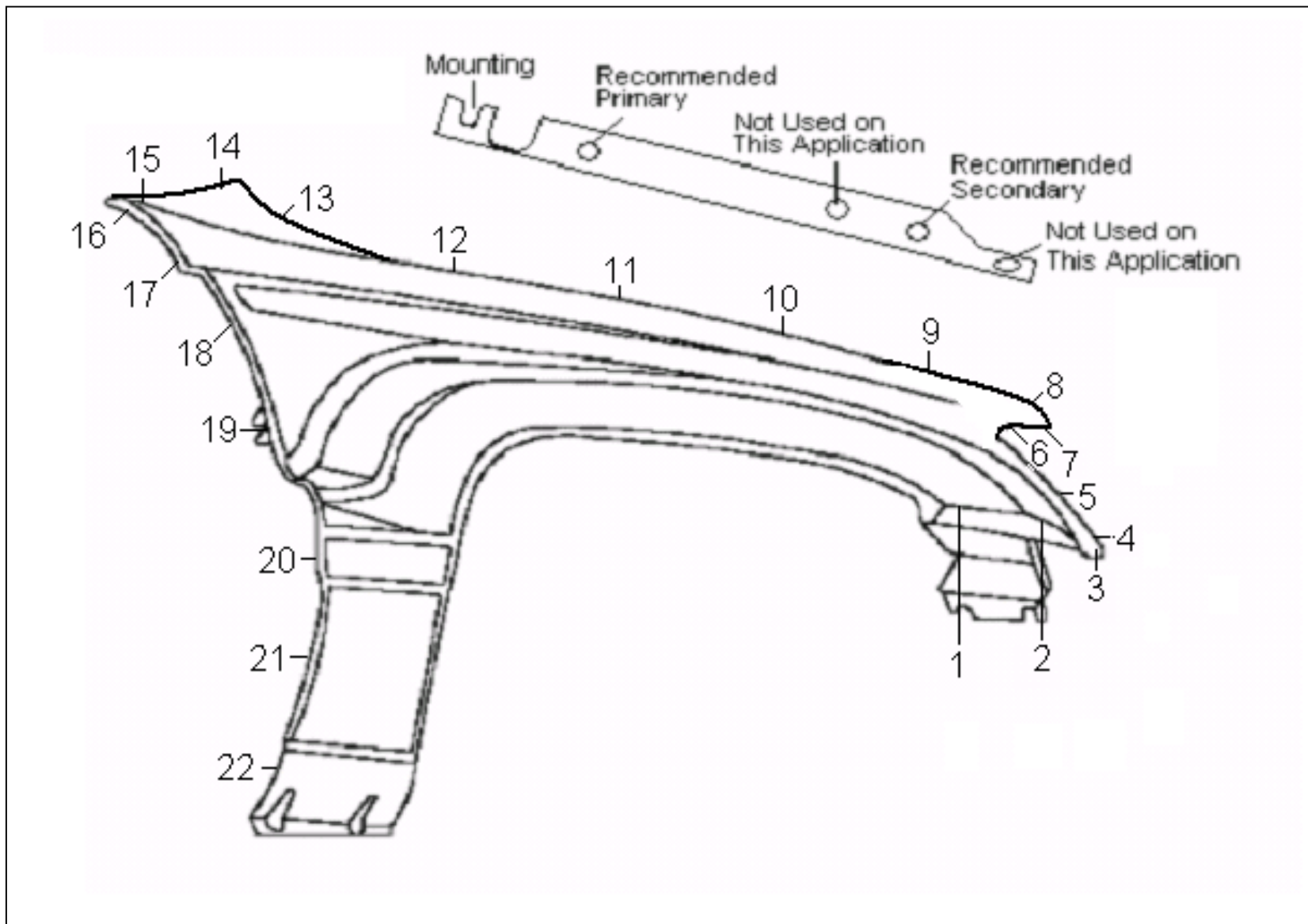

Date: 10 November 2004
CAPA Part #: JPGC99FR1
Car Company:
Service (CCS) Part #: 55135900AC

Report Number: JPGC99FR1/RDM VTF
Manufacturer: Gordon
 Jeep Grand Cherokee,
Part Application: 1999-04

Vehicle Test Fit Dimensional Results

GAP	1	2	3	4	5	6	7	8	9	10	11	12	13	14	15	16	17	18	19	20	21	22	23	24
CCO Part	/	/	/	/	/	/	/	4.1	4.9	4.6	4.3	3.8	4.0	/	/	5.3	4.9	5.2	4.4	4.5	3.5	/		
CAPA Part 1	/	/	/	/	/	/	/	4.3	3.7	3.3	3.8	3.8	3.8	/	/	SD	5.1	5.5	4.3	4.7	3.3	/		

Flush	1	2	3	4	5	6	7	8	9	10	11	12	13	14	15	16	17	18	19	20	21	22	23	24
CCO Part	/	/	/	/	/	/	/	0	-0.8	-0.7	0	0.3	1.3	/	/	0.3	-0.2	0.4	1.5	1.1	/	/		
CAPA Part 1	/	/	/	/	/	/	/	0.7	-0.5	-0.1	0.4	0.4	1.4	/	/	SD	-0.1	0.3	1.0	-0.2	/	/		

/ = Due to the fit of the test part against the adjacent part(s), a flush and/or gap measurement could not be taken at this point.

Date: 10 November 2004
CAPA Part #: JPGC99FR1
Car Company:
Service (CCS) Part #: 55135900AC

Report Number: JPGC99FR1/RDM VTF
Manufacturer: Gordon
Car Company: Jeep Grand Cherokee,
Part Application: 1999-04

Vehicle Test Fit Dimensional Results

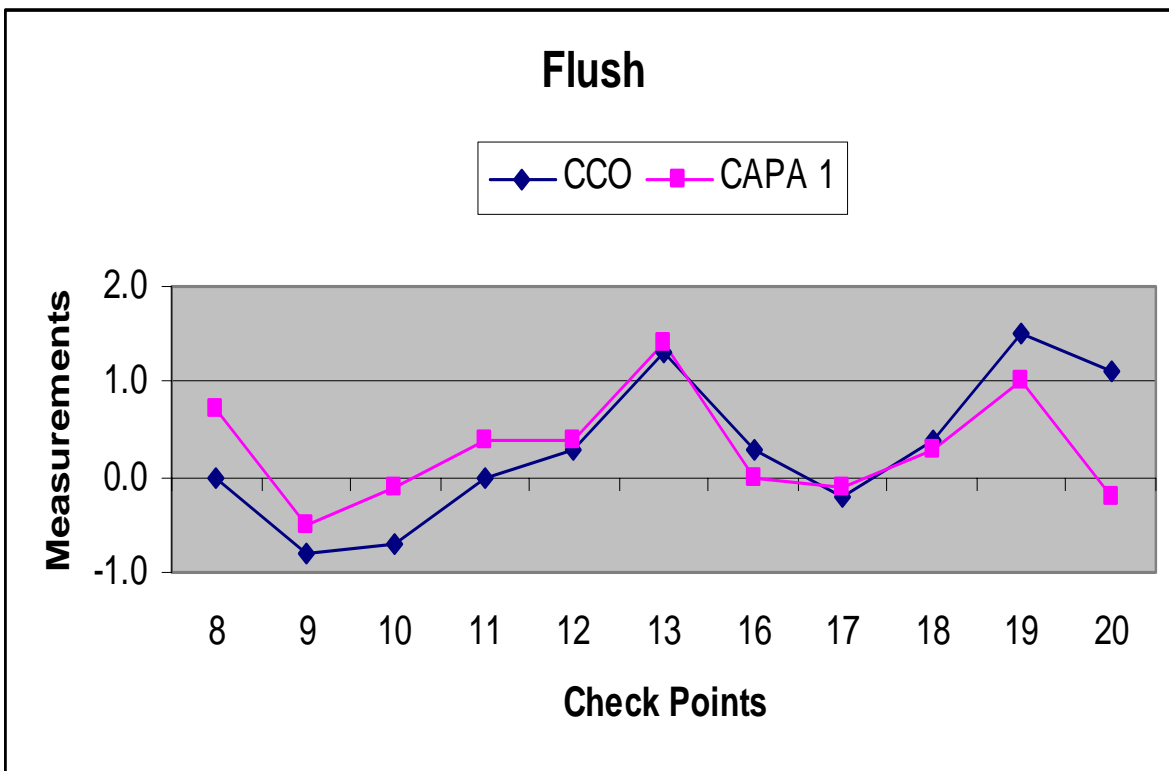
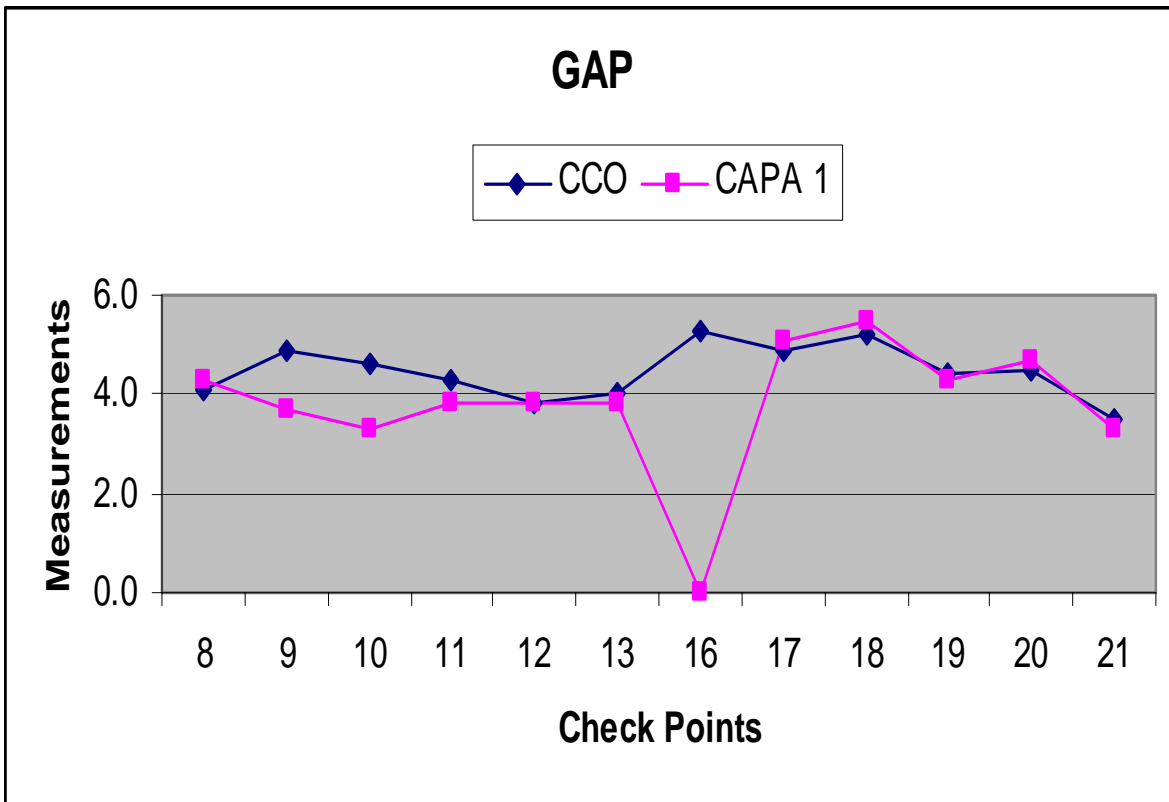

Date: 10 November 2004
CAPA Part #: JPGC99FR1
Car Company
Service (CCS) Part #: 55135900AC

Report Number: JPGC99FR1/RDM VTF
Manufacturer: Gordon
Jeep Grand Cherokee,
Part Application: 1999-04

Car Company Original (CCO) Part Fit Results RDM VTF

CAR COMPANY ORIGINAL (CCO) PART

VIN#

Fit - Pass

Fit - Fail

Date: 10 November 2004
CAPA Part #: JPGC99FR1
Car Company
Service (CCS) Part #: 55135900AC

Report Number: JPGC99FR1/RDM VTF
Manufacturer: Gordon
Jeep Grand Cherokee,
Part Application: 1999-04

CAPA Part Fit Results and Appearance Inspection RDM VTF

CAPA PART 1

Lot #:

Part Fit Results

Pass Fail

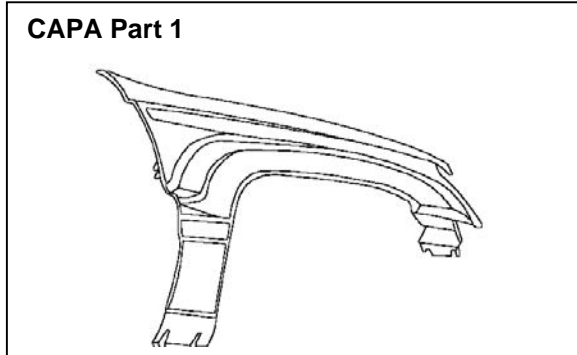

Appearance Inspection

Pass Fail

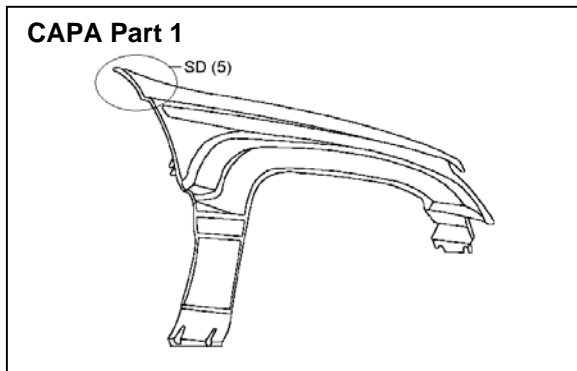

Shipping Damage Observed (SD): Yes No
SD is in the form of dents or bumps.

Problem

- | | |
|----------------------------------|---------------------------------|
| 1. Adhesive | 13. Pits |
| 2. Burrs | 14. Rinse Residue |
| 3. Chips | 15. Rolled Edges |
| 4. Corner Radius | 16. Rough Surfaces |
| 5. Dents or Bumps | 17. Scratches or Gouges |
| 6. Dirt or Foreign Matter | 18. Tool Marks |
| 7. Excess Material | 19. Underside Metal Folds |
| 8. Grind Marks | 20. Waviness/Distortion/Ripples |
| 9. Metal Fold Lines | 21. Weld Burns or Missing Welds |
| 10. Non-Uniform Coating Coverage | 22. Wet Mar |
| 11. Non-Uniform Trimming | |
| 12. Orange Peel | |

Date: 10 November 2004
CAPA Part #: JPGC99FR1
Car Company
Service (CCS) Part #: 55135900AC

Report Number: JPGC99FR1/RDM VTF
Manufacturer: Gordon
Jeep Grand Cherokee,
Part Application: 1999-04

CAPA Part Packaging Inspection

Packaging: Correct Incorrect N/A:

Date: 10 November 2004
CAPA Part #: JPGC99FR1
Car Company
Service (CCS) Part #: 55135900AC

Report Number: JPGC99FR1/RDM VTF
Manufacturer: Gordon
Jeep Grand Cherokee,
1999-04
Part Application:

VTF Photos



Date: 10 November 2004
CAPA Part #: JPGC99FR1
Car Company
Service (CCS) Part #: 55135900AC

Report Number: JPGC99FR1/RDM VTF
Manufacturer: Gordon
Jeep Grand Cherokee,
Part Application: 1999-04

Appearance Inspection Criteria

Adhesive: Missing, lack of bond or adhesive causing distortion to the Class "A" surface.

Burrs: Sharp teeth-like protrusions at the edge of the part.

Chips: Small areas where the EDP coat is missing, usually due to damage.

Corner Radius: Rounded corners that do not match the CCS Part; corners lacking material creating a hole; sharp corners resulting from excess material or poor grinding operations. Opposite corners having differently shaped radii.

Dents or Bumps: Depression or protrusions on the Class "A" surface that can be seen or felt with the back of the fingernail.

Dirt or Foreign Matter: Small particles in the EDP coat Class "A" surface that can be felt with the back of the fingernail.

Excess Material: Extra material on the part that is not seen on the CCS Part which may affect the part fit to the vehicle.

Grind Marks: Cuts in the Class "A" surface that are present after EDP which can be felt with the back of the fingernail.

Metal Fold Lines: Visible fold line on the Class "A" surface caused by crimp operation.

Non-Uniform Coating Coverage: Inconsistencies in the EDP coating such as blisters, missing or thin EDP, or drip marks that can be felt with the back of the fingernail.

Non-Uniform Trimming: Trimming inconsistencies on the Class "A" surface

Orange Peel: Rippled or wavy EDP coating on the Class "A" surface that can be felt with the back of the fingernail.

Pits: Small porous holes in the EDP coat on the Class "A" surface.

Rinse Residue: Visually detected streaking marks or discoloration left after the EDP process.

Rolled Edges: Upward bulge along the crimped edge of the part.

Rough Surfaces: Inconsistencies on the Class "A" surface that can be seen or felt with the back of the fingernail i.e. poor EDP, surface feels gritty.

Scratches or Gouges: Marks on the Class "A" surface that can be felt with the back of the fingernail. Usually caused by damage from handling or debris in the stamping process.

Tool Marks: Markings left from the tool when it draws or shapes the material into the part.

Underside Metal Folds: Edges and corners not crimped in the same manner as the CCS Part. This applies to Class "B" and "C" surfaces on the part or the underside of parts.

Waviness / Distortion / Ripples: Variations on the Class "A" surface and formed edges.

Weld Burns or Missing Welds: Welds that burn through or distort the Class "A" surface. Also welds that are missing.

Wet Mar: Smear EDP coat due to packaging prior to coat being fully dry or cured.

Date: 10 November 2004 **Report Number:** JPGC99FR1/RDM VTF
CAPA Part #: JPGC99FR1 **Manufacturer:** Gordon
Car Company: Jeep Grand Cherokee,
Service (CCS) Part #: 55135900AC **Part Application:** 1999-04

TERMS AND CONDITIONS

The following terms and conditions apply to all work performed by Intertek ETL Entela, and supercede and/or replace terms and conditions of client's purchase order unless specifically exempted in writing by an officer of Intertek ETL Entela

1. Intertek ETL Entela represents to the client that testing is done in accordance with standard procedures as applicable and that reported test results are accurate within generally accepted commercial ranges of accuracy, unless a specific measure of greater accuracy has been agreed to in writing by Intertek ETL Entela and the client.
2. Intertek ETL Entela reports apply only to the specific sample(s) tested under stated test conditions and test results are not necessarily indicative of the qualities of apparently identical or similar test or operating conditions. Intertek ETL Entela shall have no liability for any deductions, inferences or generalizations drawn by the client or others from Intertek ETL Entela reports.
3. When Intertek ETL Entela performs services, its work and reports are not governed by the Uniform Commercial Code. Except as stated in Paragraph 1, Intertek ETL Entela disclaims all warrants of merchantability or fitness for a particular purpose. Intertek ETL Entela assumes no liability for incidental or consequential damages of any nature whatsoever.
4. The client shall not advertise or publish the name, the seal or servicemark, reports, test results, documentation or procedures of Intertek ETL Entela without written authorization from Intertek ETL Entela. Any test reports provided to client by Intertek ETL Entela shall not be reproduced *except in full* without the approval of Intertek ETL Entela. The client's actual or threatened failure to abide by this Paragraph 4 may result in legal action by Intertek ETL Entela for injunctive and other relief.
5. Payment for the services rendered is the obligation of the client issuing the purchase order or accepting the proposal. The obligation is not contingent on any specific result from Intertek ETL Entela's services and may not be assigned without the written permission of Intertek ETL Entela.
6. If services are to be supplied to a client who has not established credit with Intertek ETL Entela, or in connection with a legal action, a retainer equal to the estimated cost is required with the order, which retainer may be applied at Intertek ETL Entela's option to its final billings. The minimum retainer required for services to be performed in connection with a legal action is \$1,000.
7. If the service to be performed requires more than one (1) month for completion, Intertek ETL Entela will make monthly billings of the approximate percentage of the work completed each month, supplying with the interim invoice a progress report showing accomplishments to date. Terms of all invoices shall be net cash on receipt of invoice.
8. If the client desires forensic testing services, the client must mark each test sample and supporting documents and the test authorization form conspicuously as "LEGAL". Unless otherwise indicated in writing, prices quoted or charged by Intertek ETL Entela do not include charges for any court appearance, records retrieval/storage, expert witness testimony, deposition, or affidavit, or preparation thereof, in connection with forensic testing services. Such charges will be computed at Intertek ETL Entela's then prevailing hourly rates, plus expenses. All such charges must be prepaid by the client prior to such appearance, testimony, deposition or affidavit and, where required by law, advance court approval of charges must be obtained by the client at the client's expense.
9. In the event that Intertek ETL Entela, as a result of an order or subpoena issued by a court, is called upon to produce or testify in respect to a report, it will advise the client of the fact and the time and place of the scheduled hearing, if reasonable advance notice is given to Intertek ETL Entela. If the client has any objections to Intertek ETL Entela complying with such order or subpoena, it will be the client's obligation to present such objections to the court at or prior to the time specified in such order or subpoena, and to give timely notice to Intertek ETL Entela of the results.
10. Intertek ETL Entela shall purchase, and client agrees to sell and convey title to any and all parts, assemblies, or products submitted for testing and analysis to Intertek ETL Entela for the sum of \$1.00. Upon completion of testing and analysis any and all parts, assemblies or products used or consumed during the course of our work shall be sold to and title conveyed to Client for the sum of \$1.00. Sample(s) will be destroyed thirty (30) days after the date of the final report, unless the client indicates otherwise in writing and prepays before the expiration of said 30-day period the entire cost of storing, packaging, and shipping the sample(s).
11. Prices quoted by Intertek ETL Entela are subject to change if not accepted by the client within thirty (30) days, or if the work involved is not commenced within forty-five (45) days of such acceptance through no fault of Intertek ETL Entela.
12. Intertek ETL Entela's liability for damage to or loss or destruction of the client's property while it is in the possession of Intertek ETL Entela will be limited to the amount Intertek ETL Entela has agreed to charge the client for the services.
13. Any order or agreement for testing services by Intertek ETL Entela may be terminated in writing by the client before completion thereof with Intertek ETL Entela's written consent in which event the client shall pay to Intertek ETL Entela an amount to be determined by Intertek ETL Entela as being sufficient to reimburse Intertek ETL Entela for all direct and indirect costs and expenses, including (but not limited to) suppliers, materials, labor, and overhead incurred with respect to the order or agreement through the date of termination..
14. Intertek ETL Entela shall not be liable for any failure or delay in performance which is caused in whole or in part by fire, flood, accident, riot, war, operation of law, government action, strikes or other labor disturbances, fuel shortages, or any other cause beyond the control of Intertek ETL Entela.
15. All contracts between Intertek ETL Entela and the client shall be deemed to be made in and governed by the laws of the State of Michigan.
16. Should Intertek ETL Entela be required to subcontract any testing or other services, the client will be informed of such arrangement either verbally or in writing. Intertek ETL Entela shall have no liability for any deductions, inferences, or generalizations drawn by the client or others from subcontractor's data.
17. Should witness of testing or services on Intertek ETL Entela premises be requested, the client shall comply with all applicable safety regulations and precautions. Client shall supply, if requested, evidence of workers compensation coverage prior to visit.
18. Any action taken by a client based on any consulting or recommendations as provided by ENTELA are the sole responsibility of the client or recommendations as provided by ENTELA are the sole responsibility of the client.

10/00 Revision