



## LuK Service Info



# Part Nr: 231 0043 10 — 305/305mm TGU6

Manufacturer: DAVID BROWN

Info: New design/Neues Design/Nouvelle conception/Nuevo diseño/Nuovo disegno

Model: 1594, 1690, 1690T & 1694

231 0043 10 replaces/ersetzt/  
remplace/sustituye a/sostituisce  
231 0043 40

Art.-Nr.: 231 0043 10



631 2605 09 = 231 0043 10 + 331 0122 46  
631 2605 10 = 231 0043 10 + 331 0122 46 + 500 0360 40 + 500 0537 10  
+ 410 0023 00



Bolts 3/8"UNC x 2" are supplied to fit new LuK clutch 231 0043 10.



Los tornillos 3/8"UNC x 2" se distribuyen para el nuevo modelo de embrague LuK 231 0043 10.



Schrauben 3/8"UNC x 2" passend für die neue LuK-Kupplung 231 0043 10.



Bulloni 3/8"UNC x 2" in dotazione per la nuova frizione LuK 231 0043 10.



Les boulons 3/8"UNC x 2" sont fournis pour s'adapter au nouvel embrayage LuK 231 0043 10.



231 0043 40

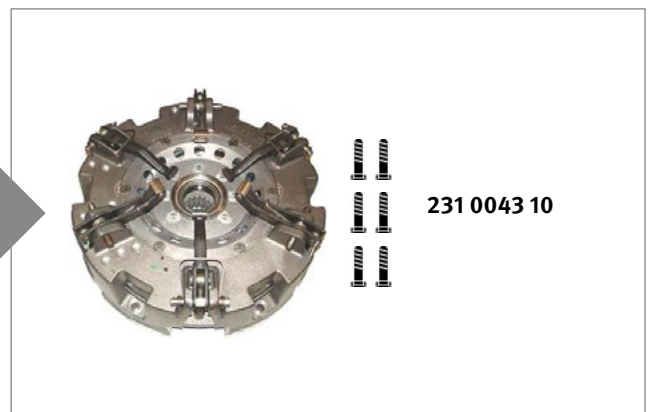

231 0043 10

- For accurate model information please see LuK catalogue
- Die genaue Fahrzeugzuordnung entnehmen Sie bitte dem LuK-Katalog
- Pour plus d'information sur les applications veuillez vous référer au catalogue LuK
- Para obtener información sobre el modelo, rogamos consulte el catálogo de LuK
- Per informazioni sul modello consultare il catalogo LuK

### You want more? We can help!

Phone: +44 (0) 1432 264 264

Fax: +44 (0) 1432 375 760

aftermarket.uk@schaeffler.com

www.repexpert.co.uk

SCHAEFFLER  
**REP>XPERT**