

Montageanleitung
Tagfahrlicht

Mounting Instructions
Daytime Running Lights

Instructions de montage
Feux diurnes

Monteringsanvisning
Varselljus

Montagehandleiding
Dagrijlichten

Instrucciones de montaje
Luces de marcha diurna

Istruzioni di montaggio
Luci di marcia diurna

Asennusohje
Huomiovalot



Lieferumfang
Kit includes
Furniture

Leveransomfatning
Inhoud set
Volumen del suministro

Dotazione di forniture
Osaluettelo

2

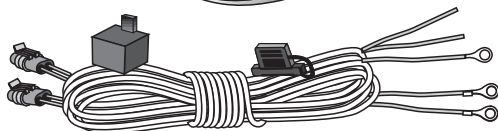

2x

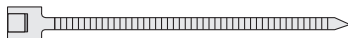

10x

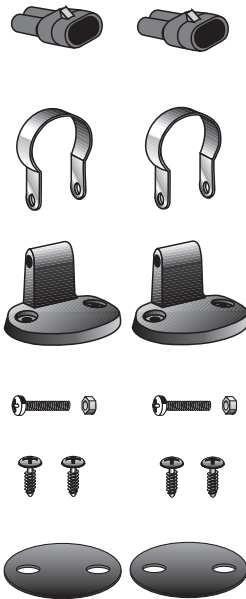

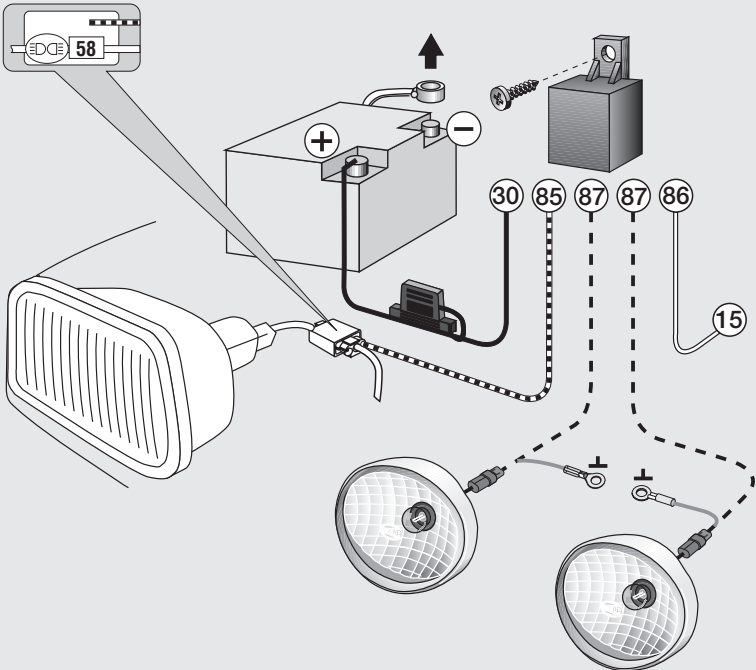

- | | | |
|--------------------|---|--|
| (30)
— | rot
red
rouge
röd | rood
rajo
rosso
punainen |
| (85)
— | grün
green
vert
grön | groen
verde
verde
vihreä |
| (86)
= | gelb/grün
yellow/green
jaune/vert
gul/grön | geel/groen
amarillo/verde
giallo/verde
keltainen/vihreä |
| (87)
- - | gelb
yellow
jaune
gul | geel
amrillo
giallo
keltainen |
| (15)
⊥ | braun
brown
marron
brun | bruin
marrón
marrone
ruskea |

4

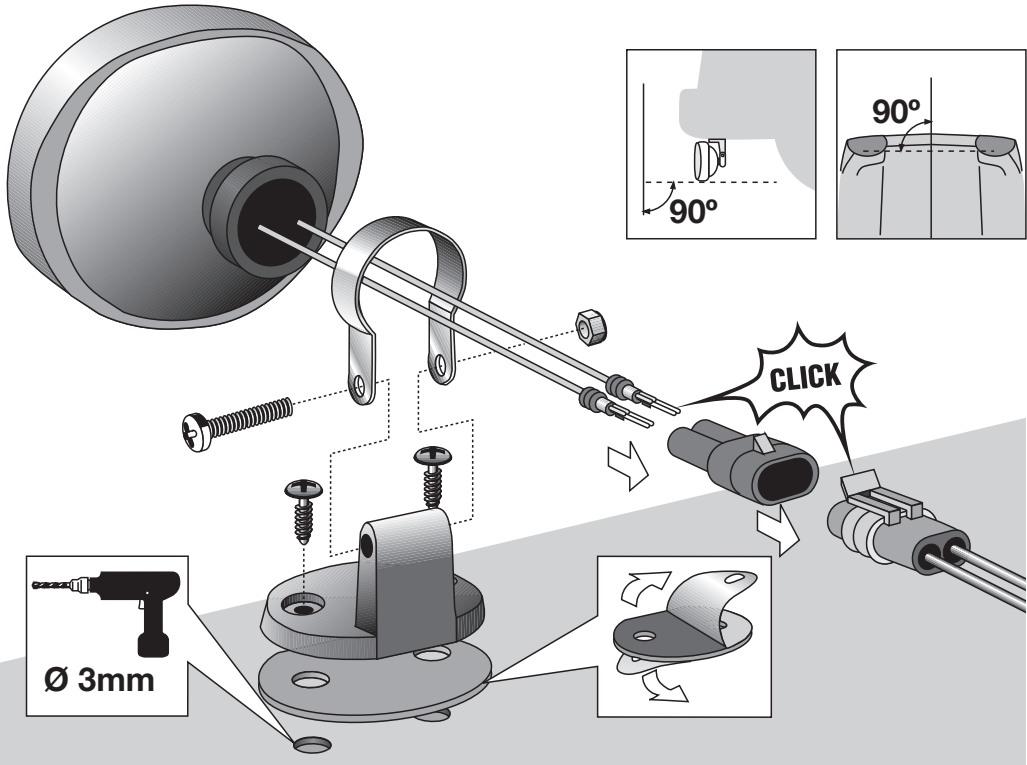

D **DEUTSCH** Technische Änderungen vorbehalten **6 - 7**

GB **ENGLISH** Subject to alteration without notice **8 - 9**

F **FRANÇAIS** Sous réserve de modifications techniques **10 - 11**

S **SVENSKA** Vi reserverar oss för tekniska ändringar **12 - 13**

NL **NEDERLANDS** Technische wijzigingen voorbehouden **14 - 15**

E **ESPAÑOL** Reservadas modificaciones técnicas **16 - 17**

I **ITALIANO** Con riserva di modifiche tecniche **18 - 19**

FIN **SUOMI** Tekniset muutokset pidätetään **20 - 21**

Benötigtes Werkzeug:

- Gliedmaßenmaßstab
 - Kreuzschlitzschraubendreher
 - Kombizange
 - Maul- oder Ringschlüssel SW 7
- Bohrmaschine mit Bohrer \varnothing 3 mm

Montage: Seite 4

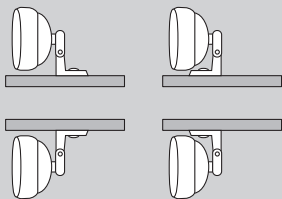

Montage hängend oder stehend, oberhalb oder unterhalb der Stoßstange möglich. Leuchten dürfen nicht vibrieren, oder über die Motorhaube ragen und müssen symmetrisch angebracht sein.

- Montageposition festlegen und Befestigungspunkte anzeichnen.
- Mit 3 mm bohren. Gebohrte Metallteile mit Rostschutz versiegeln.
- Halter an das Fahrzeug schrauben.
- Leuchten an Halter schrauben und waagrecht ausrichten.

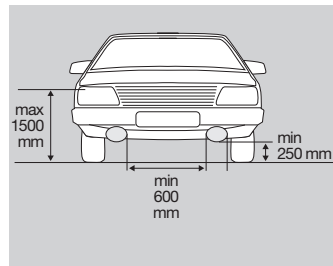

* Bei Fahrzeugen < 1300 mm Breite min. 400 mm.

TOP

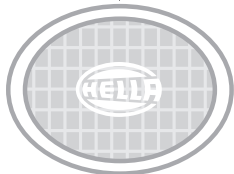

Seite 3: Elektrischer Anschluß

Masseleitung (-) der Batterie zur Sicherheit lösen.

Relais mit Anschlußklemmen spritzwassergeschützt nach unten einbauen.

Leitungen nach Schaltplan verlegen und anschließen.

Nach Schaltplan werden die Tagfahrleuchten automatisch mit der Zündung eingeschaltet.

Achtung!

Tagfahrleuchten

- sind **kein** Ersatz für Abblendlicht bei Dämmerung oder Dunkelheit.
- sie leuchten **nur** bei ausgeschalteter Fahrzeugbeleuchtung und eingeschalteter Zündung.

- sie schalten sich beim Einschalten der Fahrzeugbeleuchtung **automatisch** aus.
- sind zugelassen gemäß ECE R87
- dürfen entsprechend der EG-Richtlinie EG R97/28 bzw. ECE R48 angebaut werden.

Wir empfehlen die Montageanleitung mit den KFZ-Papieren mitzuführen.

Zum Auschalten der Tagfahrleuchte Sicherung entfernen!

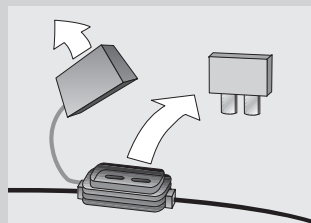
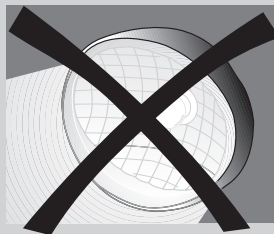

Wenn Sie Fragen oder Einbauprobleme haben: Rufen Sie den Hella Kundendienst an.

Telefon **D** (0180) 5 25 00 02
(€ 0,12/Min.)

A 01/ 6 14 60-0

CH (01) 8 72 75 75

Tools required:

- Ruler
- Phillips screwdriver
- Combination pliers
- Open end or box wrench, 7 mm

- Drill with 3 mm

Mounting steps: Page 4

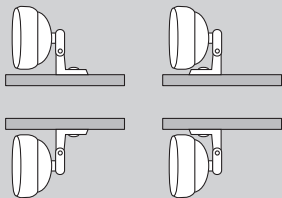

Mounting is possible upright or pendant above or below the bumper. Lamps should not vibrate or extend beyond bonnet and should be attached symmetrically.

- Determine mounting position and mark mounting points in accordance with attachment dimensions specified above.
- Drill hole with 3 mm bit. Seal drilled metal parts with rust protection agent.
- Screw mounting bracket onto vehicle.
- Screw lamps onto mounting brackets and align horizontally.

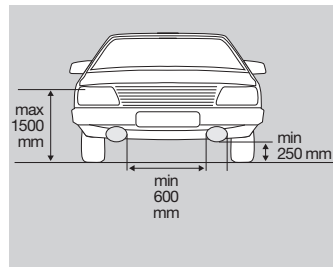

* Min. 400 mm on vehicles with widths < 1300 mm.

TOP

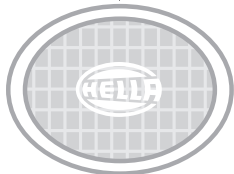

Page 3: Electrical connection

Disconnect earth lead (-) from battery as precaution.

Install relay with connection terminals downwards so that they are protected against splashing water. Route and connect leads according to circuit diagram.

According to circuit diagram, the daytime running lights are switched on automatically together with the ignition.

Caution!

Daytime running lights

- Are **not** a substitute for dipped beams at dusk or in the dark.
- Illuminate **only** when the vehicle lighting is switched off and the

ignition is switched on.

- Switch off **automatically** when the vehicle lighting is switched on.
- Are approved according to ECE R87
- May be attached according to EC Guidelines EC R97/28 and ECE R48.

We recommend keeping the mounting instructions with the vehicle papers.

To turn off the daytime running lights remove fuse.

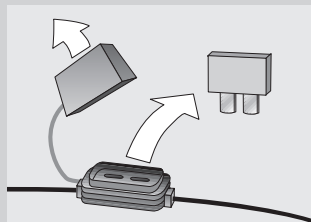
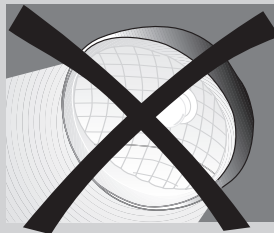

If you have any questions or problems with installation: Contact the Hella Service Department.

Outillage requis:

- Mètre
 - Tournevis cruciforme
 - Pince universelle
 - Clé plate ou polygonale de 7
- Perceuse avec mèches $\varnothing 3$

Etapas de montage: Page 3

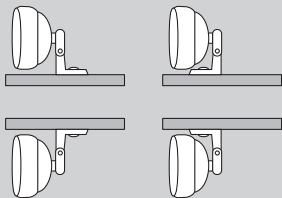

TOP

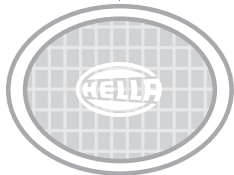

Montage vertical ou suspendu, au-dessus ou au-dessous du bouclier. Les feux ne doivent ni vibrer ni dépasser la hauteur du capot et sont à monter de façon symétrique.

- Déterminer la position de montage et repérer les points de fixation.
- Percer à $\varnothing 3$ mm. Enduire la carrosserie aux endroits percés d'un produit antirouille.
- Visser l'étrier de fixation sur le véhicule.
- Visser les feux sur l'étrier de fixation et ajuster horizontalement.

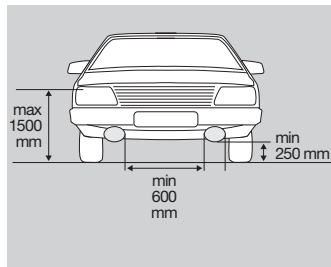

* Minimum 400 mm sur véhicules de largeur < 1300 mm.

Page 3: Branchement électrique

Par mesure de précaution déconnecter la tresse de masse (-) de la batterie.

Monter le relais avec les bornes de connexion dirigées vers le bas pour les protéger contre les projections d'eau. Poser les fils selon le schéma de connexion et effectuer les branchements.

Selon le schéma de connexion les feux diurnes s'allument automatiquement à la mise du contact.

IMPORTANT !

- Les feux diurnes **ne remplacent pas** les feux code dans l'obscurité ou la nuit.
- Les feux diurnes fonctionnent **uniquement** dans le cas où l'éclairage véhicule serait éteint et le contact mis.

- Les feux diurnes s'éteignent **automatiquement** dès l'allumage de l'éclairage du véhicule.
- Les feux diurnes sont homologués selon ECE R87.
- Les feux diurnes peuvent être montés selon la directive CE R97/28 ou ECE R48.

Conseil : conserver les instructions de montage avec les documents du véhicule.

Pour éteindre les feux diurnes retirer le fusible.

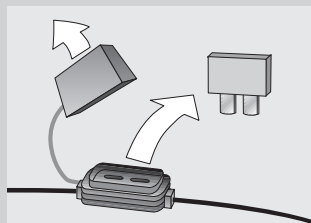
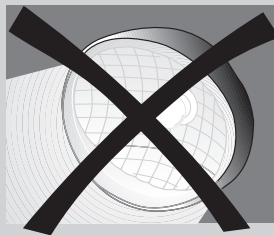

Pour tous renseignements ou problèmes de montage, veuillez s.v.p. vous adresser à votre revendeur habituel.

Nödvändiga verktyg:

- tumstock
- krysskruvmejsel
- kombitång

- U- eller ringnyckel 7
- bormaskin med borr (3 mm)

Montering: Sidan 4

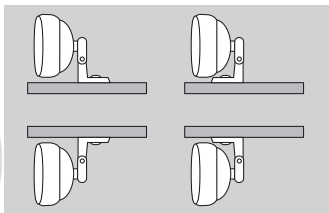

Montering kan göras hängande eller stående, över eller under stötfångaren. Lamporna får inte vibrera och de måste monteras symmetriskt.

- Bestäm monteringsläget och rita in fästningspunkterna.
- Borra med 3 mm. Rostskyddsbehandla borrade metalldelar.
- Skruva fast fästbygeln på fordonet.
- Skruva fast ljusen på fästbygeln och rikta dem vågrätt.

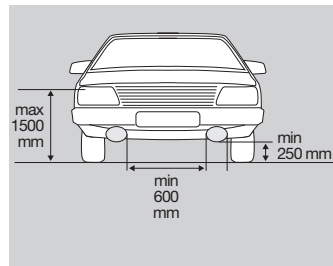

* Vid fordon < 1300 mm bredd min. 400 mm.

TOP

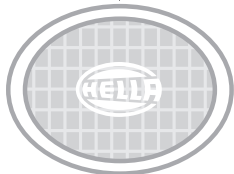

Sidan 3: Elektrisk anslutning

Lossa för säkerhets skull batteriets jordledning (-).

Montera relät stänkvattenskyddat med anslutningarna nedåt.

Drag och anslut ledningarna enligt kopplingsschemat.

Enligt kopplingsschema tillkopplas varselljusen automatiskt när tändningen slås på.

Observera!

Varselljus

- är **ingen** ersättning för halvljus i skymning och mörker;
- lyser **bara** när huvudstrålkastarna är frånkopplade och tändningen tillkopplad;

- slår från **automatiskt** när huvudstrålkastarna tillkopplas;
- är godkända enligt ECE R87;
- får monteras motsvarande EG-riktlinje EG R97/28 resp. ECE R48.

Vi rekommenderar att du har med monteringsanvisningen i bilen tillsammans med fordonsdokumenten.

För att stänga av varselljusen så tar man ur säkringen.

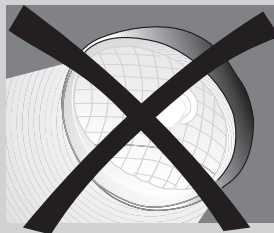

=

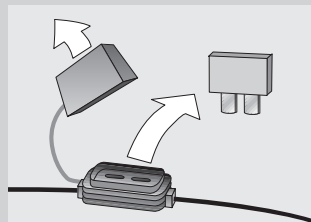

Benodigd gereedschap:

- rolmaat of duimstok
- kruiskopschroevendraaier
- combinatietang
- steek- of ringsleutel 7 mm

- boormachine met boren 3 mm

Montage stapsgewijs: Pagina 4

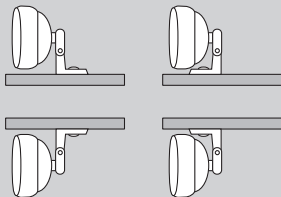

Montage hangend of staand, op of onder de bumper mogelijk. Lampen mogen niet trillen en boven de motorkap uitsteken en moeten symmetrisch worden aangebracht.

- Montageplaats kiezen en bevestigingspunten aantekenen.
- Boren met 3 mm. Gat met roestbeschermend middel behandelen.
- Lampsteunen op auto monteren.
- Lampen op lampsteunen monteren en horizontaal uitrichten.

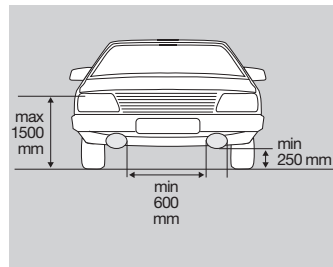

* Bij voertuigen < 1300 mm breedte min. 400 mm.

TOP

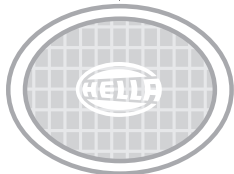

Pagina 3: elektrische aansluiting

Massakabel (-) van de accu loskoppelen.

Relais met aansluiting tegen spatwater beschermd naar beneden monteren. Kabels volgens schema aanleggen en aansluiten.

Bij schema worden de dagrijlichten automatisch met het contact ingeschakeld.

Let op! Dagrijlichten

- is **geen vervanger** voor dimlicht bij slecht zicht of in het donker.
- brandt **alleen** bij uitgeschakelde verlichting en ingeschakeld contact.

- schakelt **automatisch** uit als de verlichting wordt ingeschakeld.
- is toegestaan volgens ECE R87
- mag overeenkomstig de EG-richtlijn EG R97/28 of ECE R48 worden gemonteerd.

Wij raden u aan deze montagehandleiding bij de autopapieren te bewaren.

Voor het uitschakelen van de dagrijlichten, de zekering verwijderen.

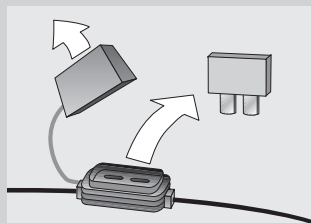
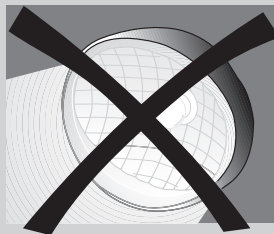

Als u vragen of montageproblemen heeft, neem dan contact op met de Hella service-afdeling.

Telefoon  030-6 09 56 72

 03-8 87 97 21

Herramientas necesarias:

- Metro plegable
- Atornillador cruciforme
- Alicates combinados
- Llave de boca o de estrella ancho de boca 7

Montaje: Página 4

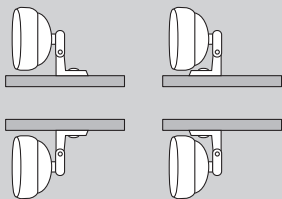

Montaje colgado o de pie, por encima o por debajo del parachoques. Las luces no deberán vibrar ni sobresalir por encima del capó del motor y deberán ser montadas simétricamente.

- Determinar la posición de montaje y marcar los puntos de posición.
- Taladrar con taladro de 3 mm. Aplicar protección anticorrosiva a las partes de metal taladradas.
- Atornillar al vehículo el estribo de sujeción.
- Atornillar las luces al estribo de sujeción y alinear horizontalmente.

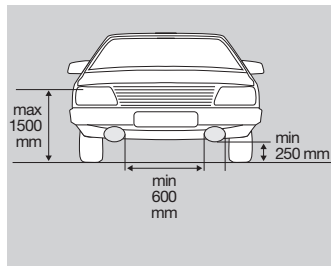

* En los vehículos < 1300 mm el ancho deberá ser de 400 mm como mín.

TOP

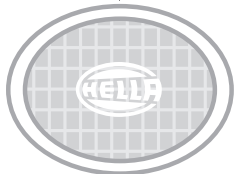

Página 3: Conexión eléctrica

Relé con bornes de conexión montaje protegido contra salpicaduras de agua y hacia abajo.

Tender los cables según el esquema de conexiones y conectarlos.

Según el esquema de conexiones las luces de marcha diurna se conectan automáticamente al conectar el encendido.

¡Atención!

- Las luces de marcha diurna **no** reemplazan la luz de cruce durante el crepúsculo o la oscuridad.
- Tales lucen **sólo** al estar desconectado el alumbrado del vehículo y conectado e encendido

- Se conectan **automáticamente** al conectar el alumbrado del vehículo
- Homologadas según directriz CEE R87
- Pueden ser montadas según la directriz CE R97/28 o CEE R48.

Es recomendable llevar siempre las instrucciones de montaje en la documentación del vehículo.

17 Para apagar la luces de marcha diurna, se debe quitar el fusible.

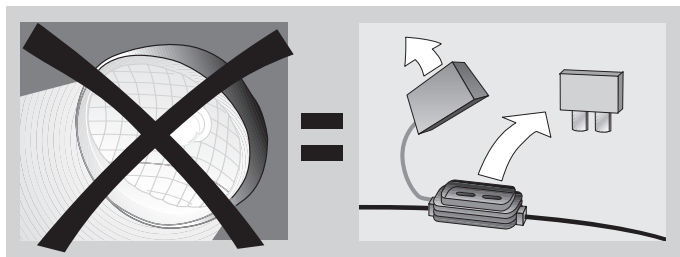

En caso de consultas o problemas de montaje, póngase en contacto con el servicio posventa de Hella.

Attrezzi necessari:

- Riga centimetrata
- Cacciavite a stella
- Pinza universale
- Chiave fissa da 7
- Trapano con punta \varnothing 3 mm

Montaggio: Pag. 4

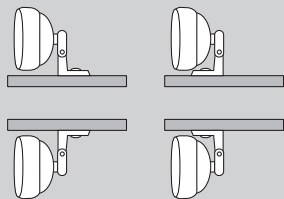

Montaggio ritto o appeso, sopra o sotto il paraurti. Le luci non devono vibrare o sporgere dal cofano motore e devono essere applicate simmetricamente.

- Definire la posizione di montaggio e contrassegnare i punti di fissaggio.
- Praticare fori da 3 mm
Trattare i punti forati con protezione antiruggine.
- Fissare la staffa alla vettura.
- Fissare la luci alla staffa e verificare il loro allineamento.

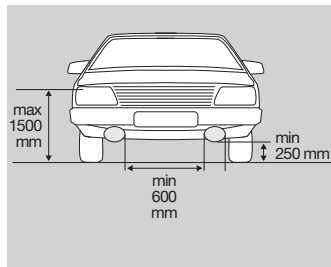

* Nelle vetture < 1300 mm di larghezza distanza min. tra i proiettori 400 mm.

TOP

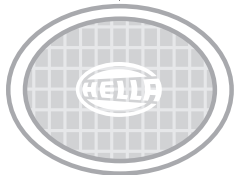

Pag. 3: Collegamento elettrico

Per precauzione staccare il cavo di massa (-) della batteria.

Installare il relais con gli attacchi verso il basso in un punto protetto dagli spruzzi d'acqua.

Posare i cavi secondo gli schemi e procedere ai relativi collegamenti.

Secondo schema la luci diurne si accenderanno automaticamente all'avviamento della vettura.

Attenzione!

Luci di marcia diurna

- **Non** sostituiscono la luce anabbagliante.
- Si accendono **soltanto** con l'accensione luci della vettura non inserita e con l'avviamento inserito. encendido

- Si spengono **automaticamente** inserendo l'accensione luci della vettura.
- Sono ammessi secondo CEE R 87.
- Devono essere montati secondo le direttive europee R 97/28 e CEE R48.

Raccomandiamo di allegare le istruzioni di montaggio ai vostri documenti di bordo.

Per disattivare le luci di marcia diurna, togliere il fusibile.

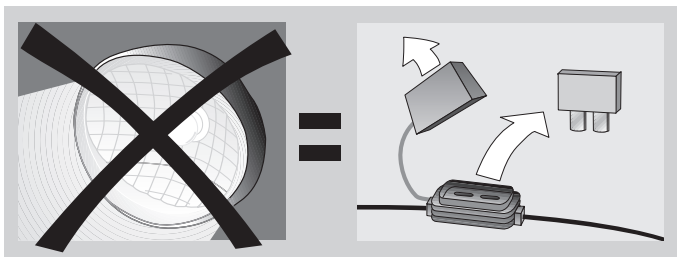

In caso di dubbi o problemi rivolgetevi al vostro fornitore di fiducia.

Tarvittavat asennusväkalut:

- Mitat
- Ristipääruuvimeisseli
- Pihdit

- Kiintoavain 7 mm
- Pora ja poranterät Ø 3 mm

Asennus: Sivu 4

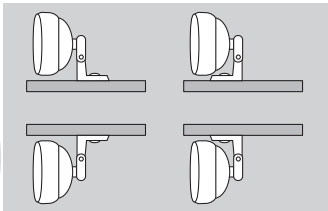

Seisova tai riippuva asennus, joko puskurin ala- tai yläpuolelle. Asenna valot tukevasti ja symmetrisesti.

- Määrittele asennuskohta ja merkitse kiinnityspisteet
- Poraa 3 mm reiät. Käsittele ruostesuojalla.
- Ruuvaa kiinnike ajoneuvoon.
- Kiinnitä valot kiinnikkeeseen ja suuntaa.

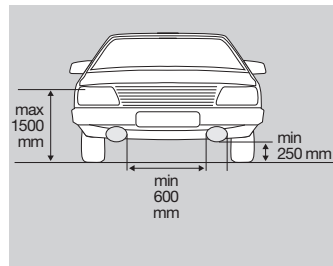

* Ajoneuvoissa, joiden leveys on enintään 1300 mm, on valojen etäisyyden oltava toisistaan min. 400 m.

TOP

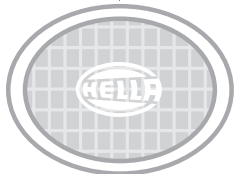

Sivu 3: Sähköliitäntä

Suomessa huomiovalaisimet on kytkettävä siten, että ne voivat palaa vain silloin, kun takavalaisimet ovat päällä, ja sammuvat kytkettäessä ajovalot päälle, paitsi jos niitä käytetään valomerkin antamiseen. Tarkista sähkökytkentä ajoneuvon maahantuojaalta.

Irrota akun maajohto (-).

Asenna rele niin, että liitäntänavat osoittavat alaspäin, jolloin rele on suojattu roiskevedeltä.

Vie johdot kytkentäkaavion mukaan ja yhdistä.

Kytkenäkaavion mukaan huomiovalot kytkeytyvät automaattisesti sytytyksen kanssa.

Huomio!

Huomiovalot

- **Eivät** korvaa lähivaloja hämärässä tai pimeässä
 - Ne valaisevat **vain**, kun ajoneuvovalaistus ei ole käytössä ja kun sytytys on päällä
 - Ne kytkeytyvät **automaattisesti** pois kun ajoneuvovalaistus kytketään päälle
 - Sallittu ECE R 87 mukaisesti
 - Asennettava EU-direktiivir EY R 97/28 tai ECE R48 mukaisesti
- Suosittelomme asennusohjeen liittämistä ajoneuvon papereihin.

Kytke huomiovalot pois päältä irrottamalla sulake.

